TECHNICAL SPECIFICATIONS

M3RL Series

High Efficiency / Direct Vent

Condensing Downflow Gas Furnace

Induced Draft - 90+ AFUE

Input 60,000 & 80,000 Btuh

The high efficiency downflow gas furnace is especially designed for Manufactured Housing. It may be installed in a utility room, or enclosed in a closet. ETL design certified for use in the United States and Canada, this product is truly designed with the installer and the consumer in mind.

Features and Benefits

- 100% fired and tested — All units and each component (both mechanical and electrical) are tested on the manufacturing line.
- Clean and quiet operation — Due to the unique design of in-shot burners, location of inducer and use of insulation.
- Fixed 30 second blower delay at burner start-up assures a warm outlet air temperature at furnace start-up. Adjustable blower off settings (60, 90, 120 and 180 seconds).
- Fixed 30-second post purge increases life of heat exchanger.
- Dependable, hot surface ignitor — Innovative application of an appliance type ignitor with a 20-year history of reliability.
- Tubular primary heat exchanger — Heavy gauge aluminumized steel heat exchanger assures a long life.
- Stainless steel secondary heat exchanger assures a long life.
- 90-second fixed cooling cycle blower-off delay (TDR) increases cooling performance when matched with a NORDYNE coil.
- Sealed combustion approved for direct vent furnace, category IV venting system — May be vertically or horizontally vented using a two-pipe system for maximum flexibility in installation.
- Multi-speed direct drive blower — Designed to give a wide range of cooling capacities. 40VA transformer included.
- LP convertible — Simple burner orifice and gas valve regulator change for ease of convertibility.
- Diagnostic light flashes identify limit failure, pressure switch failure and improper ground and polarization — for easy troubleshooting.
- 3 amp fuse protection against low voltage shorts; protects transformer and control board.
- Low voltage terminal board for easy field wiring.
- Easy open pawl latch secures the door firmly for transit, yet allows easy removal for access.
- Appliance quality door protects against rust and other corrosion. Baked enamel finish allows for easy cleaning.
- Fully insulated cabinet insures minimized heat loss and quiet operation.

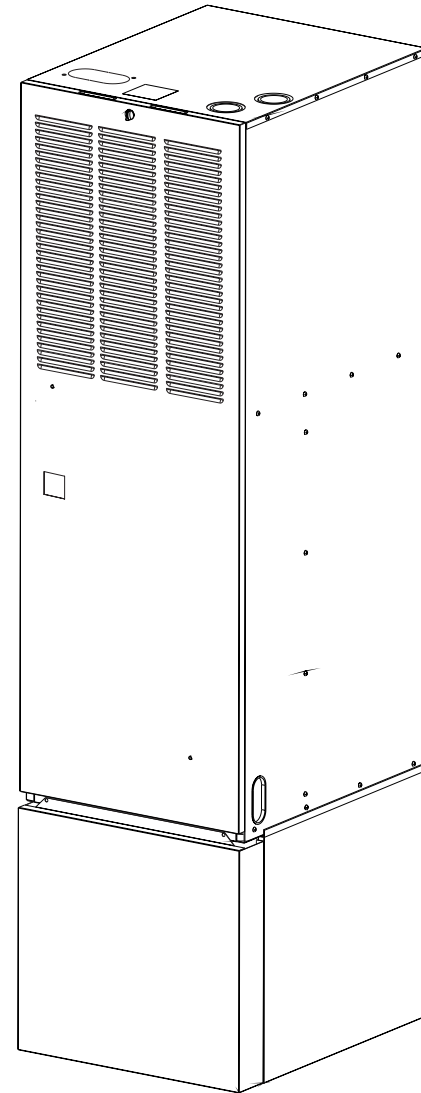

The M3RL will fit in the same footprint and uses the same plenum as the M1 furnaces. The design of the M3RL allows for direct substitution in place of the M1 series furnaces.

FEATURES

High Efficiency Downflow 90+ Gas Furnace

Downflow Furnace

- 1 Door Assembly - Louvered
- 2 Filter Inside Door
- 3 Blower Assembly
- 4 Control Board
- 5 Pressure Switch
- 6 Flame Rollout Switch
- 7 "J" Trap Hard Tube
- 8 Low Voltage Transformer
- 9 In Line Drain Assembly
- 10 Junction Box
- 11 Vent Safety Switch
- 12 Ignitor Assembly
- 13 Burner View Port
- 14 Main Limit Switch
- 15 Coil Cabinet Assembly (Optional)
- 16 Flame Sensor (On Burner Box)
- 17 Gas Valve
- 18 Switch, Blower Door
- 19 Blower, Inducer
- 20 Orifice (In Burner Box)
- 21 Aux. Limit
- 22 Burner Box

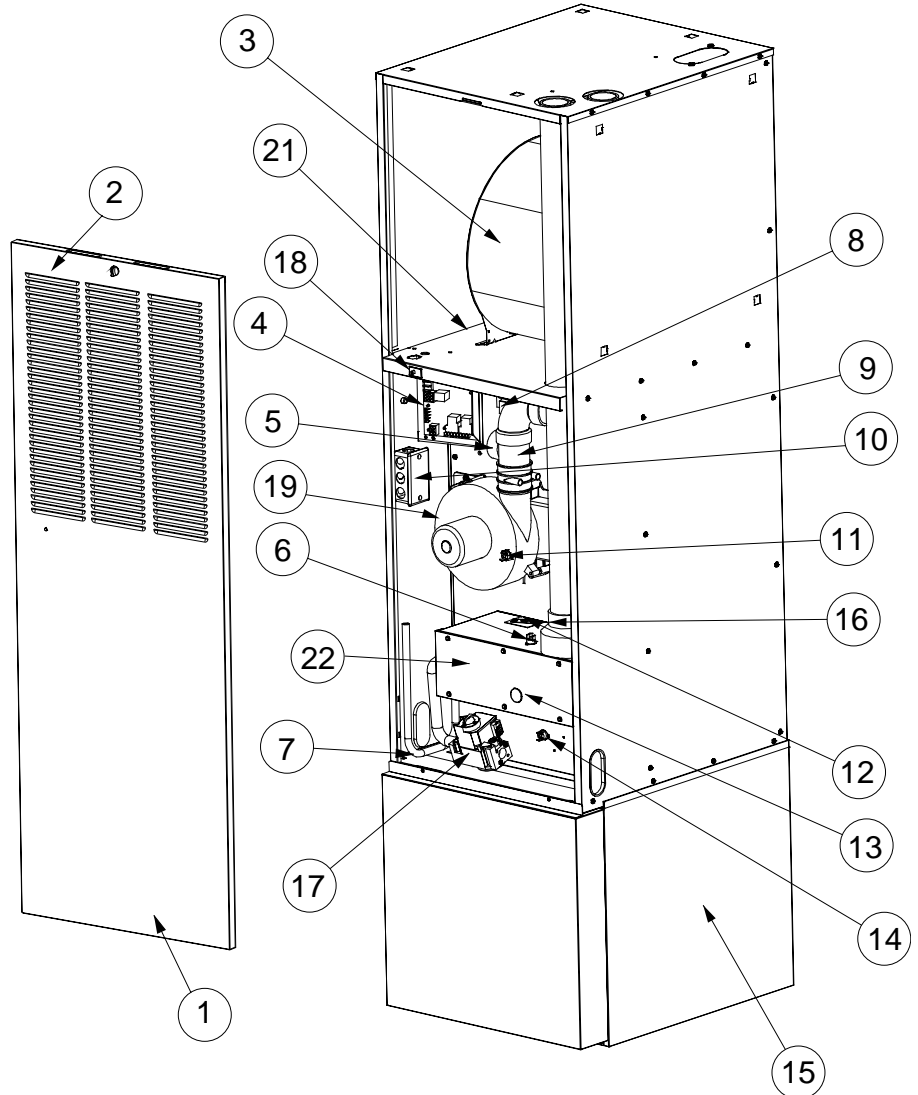

SPECIFICATIONS

M3RL MODEL NUMBERS:	-060C-16	-080C-16
Input-Btuh (a)	60,000	80,000
Heating Capacity - Btuh	54,000	72,000
AFUE	90+	90+
Blower D x W	10 x 10	10 x 10
Fuse or Breakage Size	15 Amps	15 Amps
Heat Anticipator Setting	0.5	0.5
Manifold Pressure		
Nat. Gas	3.5" WC	3.5" WC
LP Gas	10" WC	10" WC
Motor H.P. -Speed -Type	1/2 - 4 -PSC	1/2 - 4 -PSC
Motor FLA	9.0	9.0
Maximum Ext. SP - In. W.C.	0.5	0.5
Temperature Rise Range - °F	35 - 65	35 - 65

STANDARD EQUIPMENT

Direct vent; draft inducer; pressure switch; redundant main gas control; hot-surface ignition; timed ON/OFF blower controls (TDR); 40VA transformer for air conditioner application; limit controls; direct drive motor; all models can be converted to use LP (propane) gas.

Note: All models are 115V, 60 Hz. Gas Connections are 1/2" N.P.T. AFUE = Annual Fuel Utilization Efficiency
 (a) Ratings to 4,000 ft. Over 4,000 ft. reduce 4% for each 1,000 ft. above sea level.

DIMENSIONS

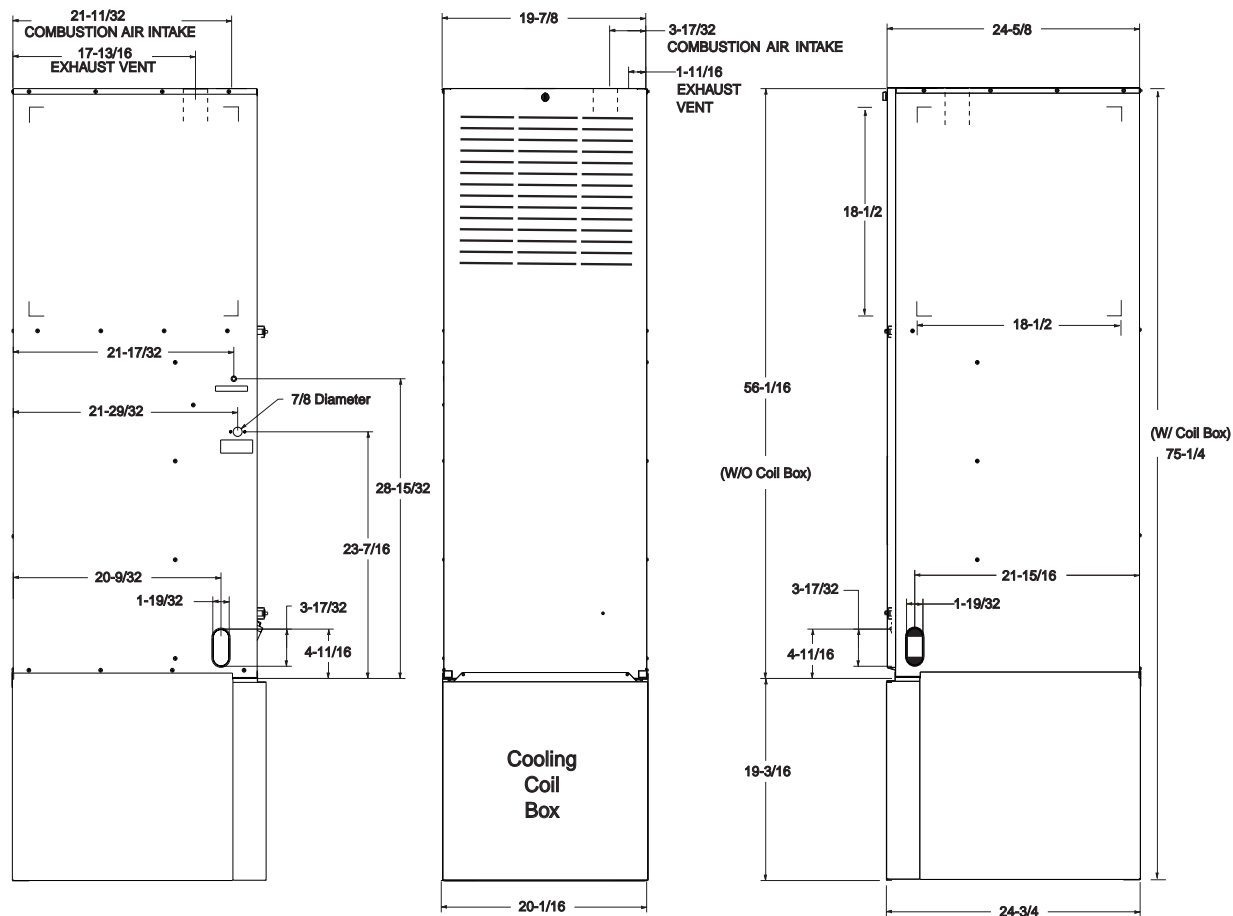

Furnace Model	Shipping Weight (lbs)
M3RL 060A AW	150
M3RL 060A BW	170
M3RL 080A AW	155
M3RL 060A BW	175

Shipping Weights

ALL MODELS	CLOSET	ALCOVE
	Inches	Inches
Front	1*	1*
Back	0	0
Sides	0	0
Vent	0	0
Top	6	6
Duct (Plenum) w/ Coil Box	0	0
w/o Coil Box (within 3 feet)	1/4	1/4

*Note: For 1" clearance, use a fully louvered door with at least 400 square inches of free airflow area.

Minimum Clearances

BLOWER PERFORMANCE

Furnace Model No.	Motor HP	Motor Speed	External Static Pressure (Inches Water Column)					Recommended A/C Ton
			0.1 CFM	0.2 CFM	0.3 CFM	0.4 CFM	0.5 CFM	
M3RL-060	1/2	High*	1399	1349	1293	1249	1190	4
		Med-High	1314	1265	1226	1168	1119	3
		Med-Low	1208	1170	1130	1076	1028	2.-1/2
		Low**	995	974	944	899	859	2
M3RL-080	1/2	High*	1399	1349	1293	1249	1190	4
		Med-High	1314	1265	1226	1168	1119	3
		Med-Low**	1208	1170	1130	1076	1028	2.-1/2
		Low	995	974	944	899	859	2

Note: Data is for Operation with Filter and Evaporator Coil.

* Factory Wired Cooling Tap

** Factory Wired Heating Tap

ACCESSORIES

Description	Part Number
Automatic Cavity Damper	901083
"VEE" Box Adapters (10") - 5 / carton	901985
Duct Connector 10" x 6" - 6 / carton	902926
"VEE" Box Adapters (12") - 5 / carton	902149
Single Wide Fitting Kit (12")	911468A
Double Wide Fitting Kit (12")	911469A
Single Wide Fitting Kit (14")	914957
Double Wide Fitting Kit (14")	914956
Y-Fitting (12")	911470
Y-Fitting (14")	917195

Vent Kits	Part Number
Soffit Air Inlet (for VentilAire III only)	917201
Wall Vent Kit (side wall depressurization)	914115
Air Tube Kit M (high capacity M Series gas/oil furnaces)	914118
VentilAire III - Sloped 3/12	914098
VentilAire IV - Sloped 3/12	914229
VentilAire IV-A - Sloped 3/12 (w/alarm)	914750

Plenum Connectors	Part Number
11.25 x 13.50 x 0.88 12 / carton	901987A
11.25 x 13.50 x 2.00 12 / carton	901988A
11.25 x 13.50 x 4.25 6 / carton	901989A
11.25 x 13.50 x 6.25 6 / carton	901990A
11.25 x 13.50 x 8.25 4 / carton	901991A
11.25 x 13.50 x 10.25 3 / carton	901992A
11.25 x 13.50 x 12.25 3 / carton	901993A
11.25 x 13.50 x 6.25 24 / carton	902681A

ACCESSORY VENT KITS

Kit	Order Number
A/C Coil Box	911969A
Side Return Air Kit	904003
Top Return Air Kit	904015
Sloped Roof VentilAire III Kit	914098
Sloped Roof VentilAire IV Kit	914229
Soffit VentilAire Kit	917201
Concentric Vent Termination Kit (for horizontal and vertical venting)	903578
Horizontal Exterior Vent Mounting Kit 3"PVC	902375
Neutralizer Kit - All Models	902377

IDENTIFICATION CODE

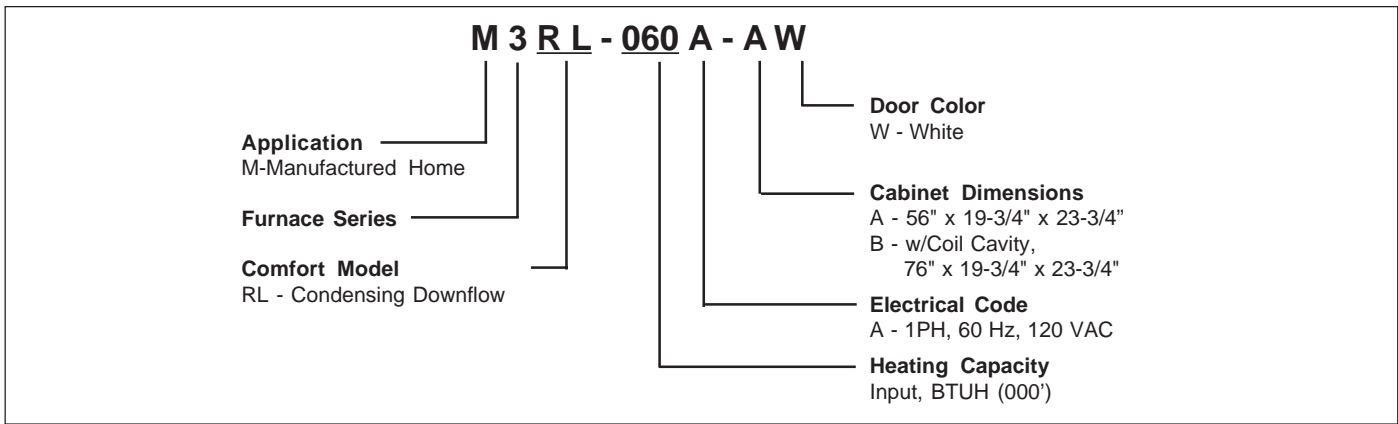

VENTING

All models are approved for both vertical and horizontal direct (2 pipe) venting applications. See Vent Table below for specified sizes and allowable lengths.

VENT TABLE

APPLICATION	DIRECT VENT, DUAL PIPE LENGTH (ft.)*	
	Inlet/Outlet	
PVC, CPVC or ABS SCH. 40 Pipe Size	3"	3"
Model M3RL 060	50	50
Model M3RL 080	50	50

*NOTES

1. Subtract 3.5 ft. for each additional 3" 90 degree elbow.
2. Two 45 degree elbows are equivalent to one 90 degree elbow.
3. One short radius elbow is equivalent to two long radius elbows
4. Do not include termination elbows in calculation of vent length
5. This table is applicable for elevations from sea level to 2000 ft. For higher elevations decrease vent pipe lengths by 8% per 1000 ft. of altitude.
6. Only the above pipe materials are approved for use with these condensing furnaces.

We Encourage
Professionalism

Through Technician
Certification by NATE



307B-0702

O'Fallon, MO

NORDYNE

Before purchasing this appliance, read important energy cost and efficiency information available from your retailer. Specifications and illustrations subject to change without notice and without incurring obligations. Printed in U.S.A. (07/02)