

Outdoor Heat Pump

User's Information/Installation Instructions

13 SEER High Efficiency Split System

These units have been designed and tested for capacity and efficiency in accordance with A.R.I. Standards. Split System Heat Pump units are designed for use with a wide variety of fossil fuel furnaces, electric furnaces, air handlers, and evaporator coil combinations.

These instructions are primarily intended to assist qualified individuals experienced in the proper installation of heating and/or air conditioning appliances. Some local codes require licensed installation/service personnel for this type of equipment. Read all instructions carefully before starting the installation.

USER'S INFORMATION

IMPORTANT

Read this owner information to become familiar with the capabilities and use of your appliance. Keep this with literature on other appliances where you have easy access to it in the future. If a problem occurs, check the instructions and follow recommendations given. If these suggestions don't eliminate your problem, call your servicing contractor.

Heat Pump Principle of Operation

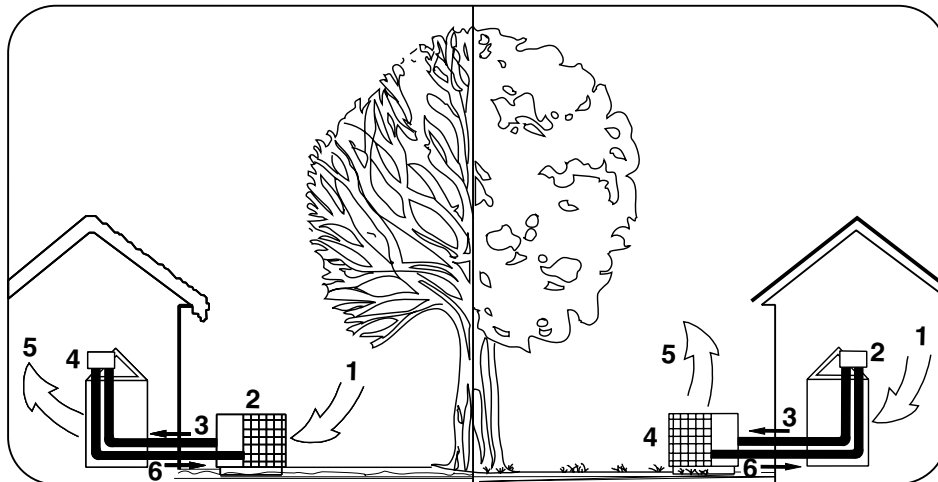

WINTER HEATING

1. Outdoor air enters heat pump.
2. Cold, heat-transfer section (outdoor coil) extracts heat from outdoor air as refrigerant evaporates from a liquid to a gas.
3. Refrigerant, compressed to a hot gas by heat pump, carries the heat to the hot heat-transfer section (indoor coil).
4. Hot, heat-transfer section (indoor coil) releases the heat to indoor air as refrigerant condenses from a gas to a liquid.
5. Air handler circulates the heat throughout the home.
6. Refrigerant returns to outdoor coil and evaporates once again to absorb more heat.

SUMMER COOLING

1. Indoor air enters the air handler section.
2. Cold, heat-transfer section (indoor coil) extracts heat from indoor air as refrigerant evaporates from a liquid to a cold gas.
3. Refrigerant, drawn to heat pump and compressed to a hot gas by heat pump, carries the heat outdoors.
4. Hot, heat-transfer section (outdoor coil) releases the heat as refrigerant condenses from a gas to a liquid.
5. Heat pump (outdoor fan) discharges the heat to outside air.
6. Refrigerant returns to indoor coil and evaporates once again to absorb more heat.

OPERATING INSTRUCTIONS

TO OPERATE YOUR HEAT PUMP FOR COOLING —

1. Set the thermostat system switch to COOL and the thermostat fan switch to AUTO. (See Figure 1)
2. Set the thermostat temperature to the desired temperature level using the temperature selector. Please refer to the separate detailed thermostat user's manual for complete instructions regarding thermostat programming. The outdoor unit and indoor blower will both cycle on and off to maintain the indoor temperature at the desired cooling level.

NOTE: If the thermostat temperature level is re-adjusted, or the thermostat system switch is repositioned, the outdoor unit may not start immediately. The outdoor unit contains a protective timer circuit which holds the unit off for approximately five minutes following a previous operation, or the interruption of the main electrical power.

TO OPERATE YOUR HEAT PUMP FOR HEATING —

1. Set the thermostat system switch to HEAT and the thermostat fan switch to AUTO. (See Figure 1)

2. Set the thermostat temperature to the desired temperature level using the temperature selector. Please refer to the separate detailed thermostat user's manual for complete instructions regarding thermostat programming. The outdoor unit and indoor blower will both cycle on and off to maintain the indoor temperature at the desired heating level.

NOTE: If the thermostat temperature level is re-adjusted, or the thermostat system switch is repositioned, the outdoor unit may not start immediately. The outdoor unit contains a protective timer circuit which holds the unit off for approximately five minutes following a previous operation, or the interruption of the main electrical power.

Emergency Heat:

The thermostat includes a system switch position termed EM. HT. This is a back-up heating mode to be used only if there is a suspected problem with the outdoor unit. With the system switch set to EM. HT. the outdoor unit will be locked off, and supplemental heat (typically electric resistance heating) will be used as a source of heat. Sustained use of electric resistance heat in place of the heat pump will result in an increase in electric utility costs.

Defrost:

During cold weather heating operation, the outdoor unit will develop a coating of

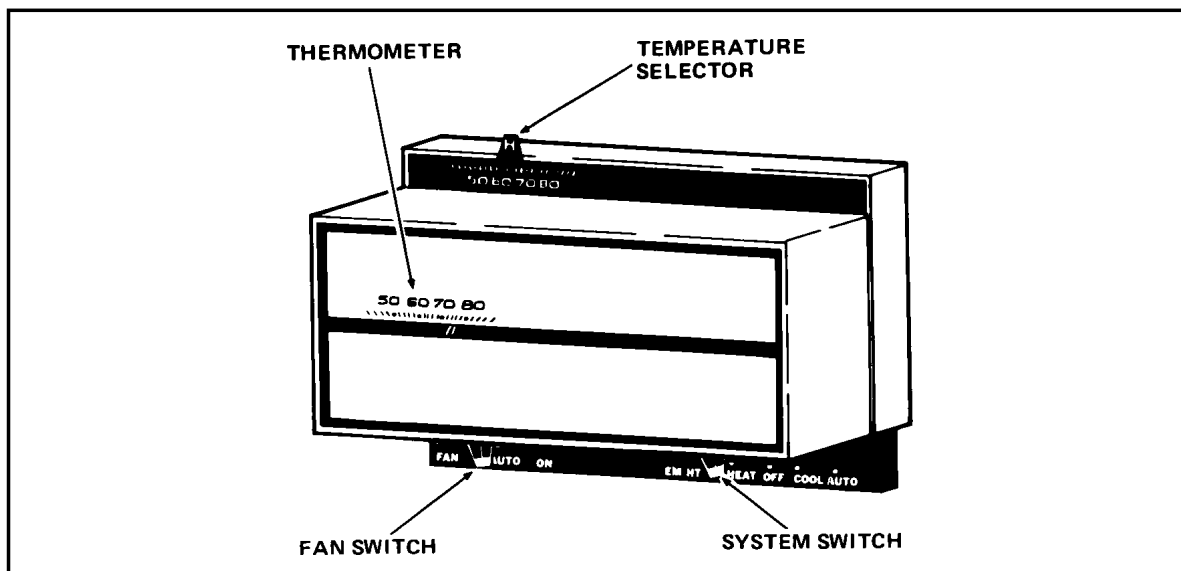

Figure 1. Typical Thermostat

snow and ice on the heat transfer coil. This is normal, and the unit will periodically defrost itself. During the defrost cycle, the outdoor fan will stop, and the compressor will continue to run and heat the outdoor coil, causing the snow and ice to melt. After the snow and ice have melted, some steam may rise from the outdoor unit as the warm coil causes some melted frost to evaporate.

TO OPERATE YOUR HEAT PUMP FOR AUTOMATIC COOLING AND HEATING

1. Set the thermostat system switch to AUTO and the thermostat fan switch to AUTO. (See Figure 1)

Note: Thermostats will vary. Some models will not include the AUTO mode, and others will have the AUTO in place of the HEAT and COOL, and some will include all three.

2. Set the thermostat temperature to the desired heating and cooling temperature level(s). The outdoor unit and the indoor blower will then cycle on and off in either the heating or cooling mode of operation as required to automatically maintain the indoor temperature within the desired limits.

TO SHUT OFF YOUR HEAT PUMP —

Set the thermostat system switch to OFF and the thermostat fan switch to AUTO. (See Figure 1) The system will not operate, regardless of the thermostat temperature selector(s) setting.

TO OPERATE THE INDOOR BLOWER CONTINUOUSLY —

Set the thermostat fan switch to ON (See Figure 1). The indoor blower will start immediately, and will run continually until the fan switch is reset to AUTO.

The continuous indoor blower operation can be obtained with the thermostat system switch set in any position, including OFF.

The continuous indoor blower operation is typically used to circulate the indoor air to equalize

a temperature unbalance due to a sun load, cooking, or fireplace operation.

TO MAINTAIN YOUR HEAT PUMP —



CAUTION:

Be certain the electrical power to the outdoor unit and the furnace/air handler is disconnected before doing the following recommended maintenance.

1. Regularly:

- a. Clean or replace the indoor air filter at the start of each heating and cooling season, and when an accumulation of dust and dirt is visible on the air filter. Inspect the filter monthly.
- b. Remove any leaves and grass clippings from the coil in the outdoor unit, being careful not to damage the aluminum fins.
- c. Check for any obstruction such as twigs, sticks, etc.



CAUTION:

Do not over-oil, or oil motors not factory-equipped with oil tubes. The compressor is hermetically “sealed” and does not require lubrication.

2. Before Calling a Service Technician, Be Certain:

- a. The unit thermostat is properly set — see “To Operate Your Heat Pump for Cooling” and “To Operate Your Heat Pump for Heating.”
- b. The unit disconnect fuses are in good condition, and the electrical power to the unit is turned on.

Read Your Warranty

Please read the separate warranty document completely. It contains valuable information about your system.

GENERAL INFORMATION

Read the following instructions completely before performing the installation.

Outdoor Unit Section — Each outdoor unit is shipped with a refrigerant charge adequate to operate the outdoor section with an indoor matching coil or air handler. Units with braze connections include the proper amount of refrigerant for an additional 15 ft. of refrigerant lines the same size as the valve fittings.

NOTE: DO NOT USE ANY PORTION OF THE CHARGE FOR PURGING OR LEAK TESTING.

Matching coils and air handlers may be shipped with a small holding charge to pressurize them to keep out contaminants. To release the pressure, read the indoor section installation instructions carefully.

Liquid and Suction Lines — Fully annealed, refrigerant grade copper tubing should be used when installing the system. Refrigerant suction line tubing should be fully insulated.

Field Connections for Electrical Power Supply — All wiring must comply with current provisions of the “National Electrical Code” (ANSI/NFPA 70) and with applicable local codes having jurisdiction. The minimum size of electrical conductors and circuit protection must be in compliance with information listed on the outdoor unit data label.

SAFETY CONSIDERATIONS

Pressures within the System — Split system heat pump equipment contains liquid and gaseous refrigerant under pressure. Installation and servicing of this equipment should be accomplished by qualified, trained personnel thoroughly familiar with this type of equipment. Under no circumstances should the Homeowner attempt to install and/or service the equipment.

Labels, Tags, Precautions — When working with this equipment, follow all precautions in the literature, on tags, and on labels provided with the equipment. Read and thoroughly understand the instructions provided with the equipment prior to performing the installation and operational checkout of the equipment.

Brazing Operations — Installation of equipment may require brazing operations. Safety codes must be complied with. Safety equipment (e.g.; safety glasses, work gloves, fire extinguisher, etc.) must be used when performing brazing operations.



WARNING:

Ensure all electrical power to the unit is off prior to installing or servicing the equipment. Failure to do so may cause personal injury or death.

SITE PREPARATION

Unpacking Equipment — Remove the cardboard carton and User's Manual from the equipment. Take care to not damage tubing connections when removing from the carton.

Inspect for Damage — Inspect the equipment for damage prior to installing the equipment at the job site. Ensure coil fins are straight and, if necessary, comb fins to remove flattened and bent fins.

Preferred Location of the Outdoor Unit at the Job Site — Conduct a survey of the job site to determine the optimum location for mounting the outdoor unit. Overhead obstructions, poorly ventilated areas, and areas subject to accumulation of debris should be avoided. The outdoor unit must be installed in such a manner that airflow through the coil is not obstructed and that the unit can be serviced.

Facility Prerequisites — Electrical power supplied must be adequate for proper operation of the equipment. The system must be wired and provided with circuit protection in accordance with local building codes and the National Electrical Code.

INSTALLING THE OUTDOOR UNIT

Slab Mount — The site selected for a slab mount installation requires a stable foundation and one not subject to erosion. The slab should be level and anchored (if necessary) prior to placing the equipment on the slab.

Cantilever Mount — The cantilever mount should be designed with adequate safety factor to support the weight of the equipment, and for loads subjected to the mount during operation. Installed equipment should be adequately secured to the cantilever mount and levelled prior to operation of the equipment.

Roof Mount — The method of mounting should be designed so as not to overload roof structures nor transmit noise to the interior of the structure. Refrigerant and electrical line should be routed through suitably waterproofed openings to prevent water leaking into the structure.

INSTALLING THE INDOOR UNIT

The indoor section should be installed before proceeding with routing of refrigerant piping. Consult the Installation Instructions of the indoor unit (i.e.: air handler, furnace, etc.) for details regarding installation.

CONNECTING REFRIGERANT TUBING BETWEEN THE INDOOR AND OUTDOOR UNIT

General — Once outdoor and indoor unit placement has been determined, route refrigerant tubing between the equipment in accordance with sound installation practices. Refrigerant tubing should be routed in a manner that minimizes the length of tubing and the number of bends in the tubing. Refrigerant tubing should be supported in a manner that the tubing will not vibrate or abrade during system operation. Tubing should be kept clean of foreign debris during installation and installation of a liquid line filter drier is recommended if cleanliness or adequacy of system evacuation is unknown or compromised. Every effort should be made by the installer to ensure that the field installed, refrigerant containing components of the system have been installed in accordance with these instructions and sound installation practices so as to insure reliable system operation and longevity.

The maximum recommended interconnecting refrigerant line length is 75 feet, and the vertical elevation difference between the indoor and outdoor sections should not exceed 20 feet.

Consult long line application guide for installations in excess of these limits.

Filter Dryer Installation — A filter dryer is provided with PS series models only and must be installed in the liquid line of the system. If the installation replaces a system with a filter dryer already present in the liquid line, the filter dryer must be replaced with the one supplied with the unit. The filter dryer must be installed in strict accordance with the manufacturer's installation instructions.

For all other series models, installing a filter dryer is optional. However, it is good installation practice to install a filter dryer when replacing the evaporator and/or condenser of a system. When installing, the filter dryer must be installed in strict accordance with the manufacturer's installation instructions.

Optional Equipment — Optional equipment (e.g.: liquid line solenoid valves, etc.) should be installed in strict accordance with the manufacturer's installation instructions.

ELECTRICAL CONNECTIONS



WARNING:

Turn off all electrical power at the main circuit box before wiring electrical power to the outdoor unit. Failure to comply may cause severe personnel injury or death.

Wiring Diagram/Schematic — A wiring diagram/schematic is located on the inside cover of the electrical box of the outdoor unit. The installer should become familiar with the wiring diagram/schematic before making any electrical connections to the outdoor unit.

Outdoor Unit Connections — The outdoor unit requires both power and control circuit electrical connections. Refer to the unit wiring diagram/schematic for identification and location of outdoor unit field wiring interfaces.

Control Circuit Wiring — The outdoor unit is designed to operate from a 24 VAC Class II control circuit. Control circuit wiring must comply with the current provisions of the “National Electrical Code” (ANSI/NFPA 70) and with applicable local codes having jurisdiction.

Thermostat connections should be made in accordance with the instructions supplied with the thermostat, and with the instructions supplied with the indoor equipment. A typical residential installation with a heat pump thermostat and air handler are shown below.

Electrical Power Wiring — Electrical power wiring must comply with the current provisions of the “National Electrical Code” (ANSI/NFPA 70) and with applicable local codes having jurisdiction. Use of rain tight conduit is recommended. Electrical conductors shall have minimum circuit ampacity in compliance with the outdoor unit rating label. The facility shall employ electrical circuit protection at a current rating no greater than that indicated on the outdoor unit rating label. Refer to the unit wiring diagram for connection details.

Minimum Circuit Ampacity — Electrical wiring to the equipment must be compatible and in compliance with the minimum circuit ampacity listed on the outdoor unit data label.

COPPER WIRE SIZE — AWG (1% Voltage Drop)				
Supply Wire Length-Feet				Supply Circuit
200	150	100	50	Ampacity
6	8	10	14	15
4	6	8	12	20
4	6	8	10	25
4	4	6	10	30
3	4	6	8	35
3	4	6	8	40
2	3	4	6	45
2	3	4	6	50

Wire Size based on N.E.C. for 60° type copper conductors.

Maximum Fuse/Circuit Breaker Size — Circuit protection for the outdoor unit must be compatible with the maximum fuse/circuit breaker size listed on the outdoor unit data label.

Disconnect Switch — An electrically compatible disconnect switch must be within line of sight of the outdoor unit. This switch shall be capable of electrically de-energizing the outdoor unit.

Optional Equipment — Optional equipment requiring connection to the power or control circuits must be wired in strict accordance with current provisions of the “National Electrical Code” (ANSI/NFPA 70), with applicable local codes having jurisdiction, and the installation instructions provided with the equipment. Optional Equipment (e.g.: liquid line solenoid valves, hard start kits, low suction pressure cutout switch kit, high pressure cutout switch kit, refrigerant compressor crankcase heater, etc.) should be installed in strict accordance with the manufacturer’s installation instructions.

STARTUP AND CHECKOUT

WARNING:

Ensure electrical power to the unit is off prior to performing the following steps. Failure to do so may cause personal injury or death.

Air Filters — Ensure air filters are clean and in place prior to operating the equipment.

Thermostat — Set the room thermostat function switch to OFF, fan switch to AUTO, and adjust the temperature setpoint to its highest setting.

Prior to applying electrical power to the outdoor unit, ensure that the unit has been properly and securely grounded, and that power supply connections have been made at both the facility power interface and outdoor unit.

Outdoor Unit — Ensure the outdoor coil and top of the unit are free from obstructions and debris, and all equipment access/control panels are in place.

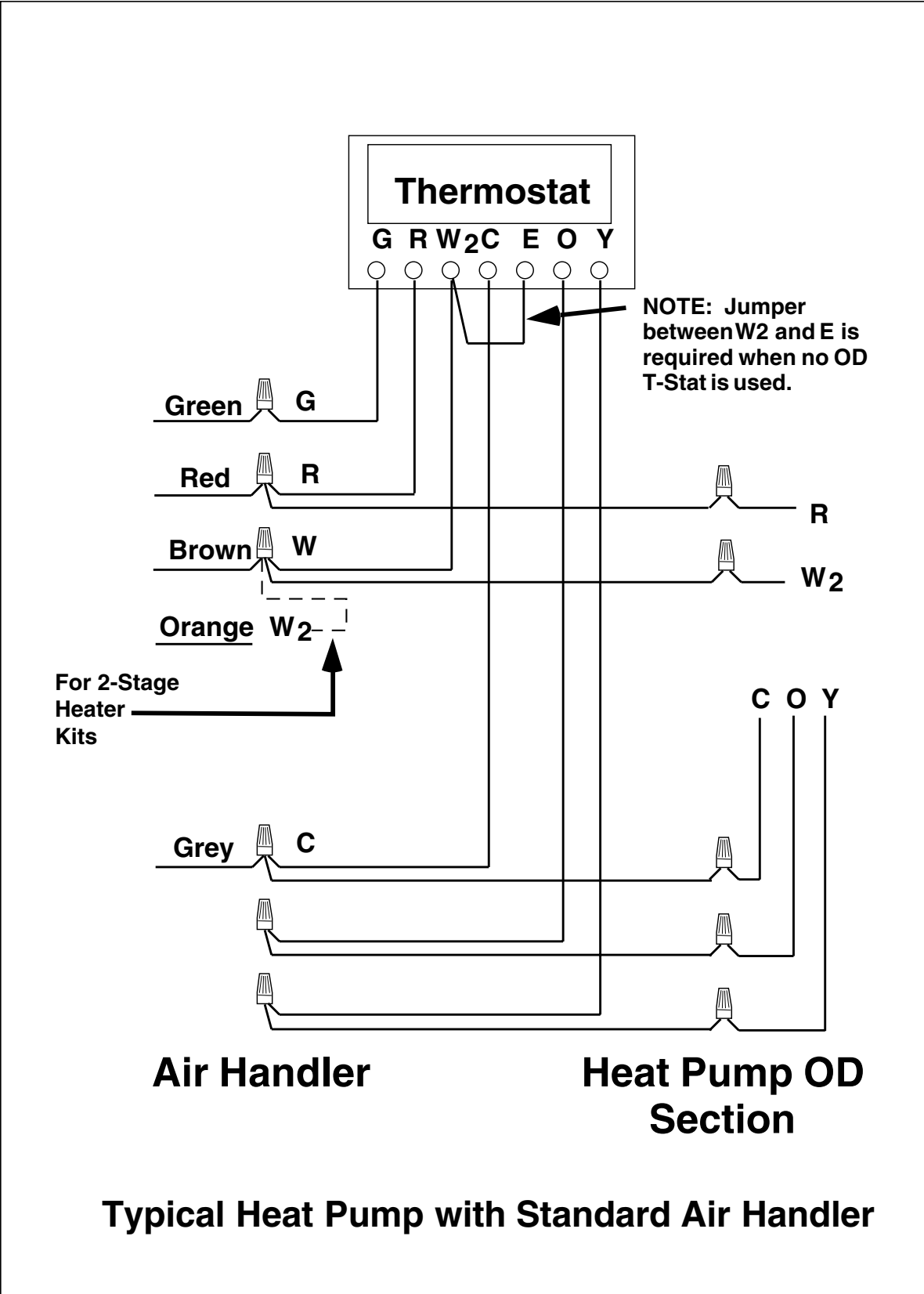

A typical installation with a heat pump thermostat, air handler, and heat pump with an outdoor thermostat.

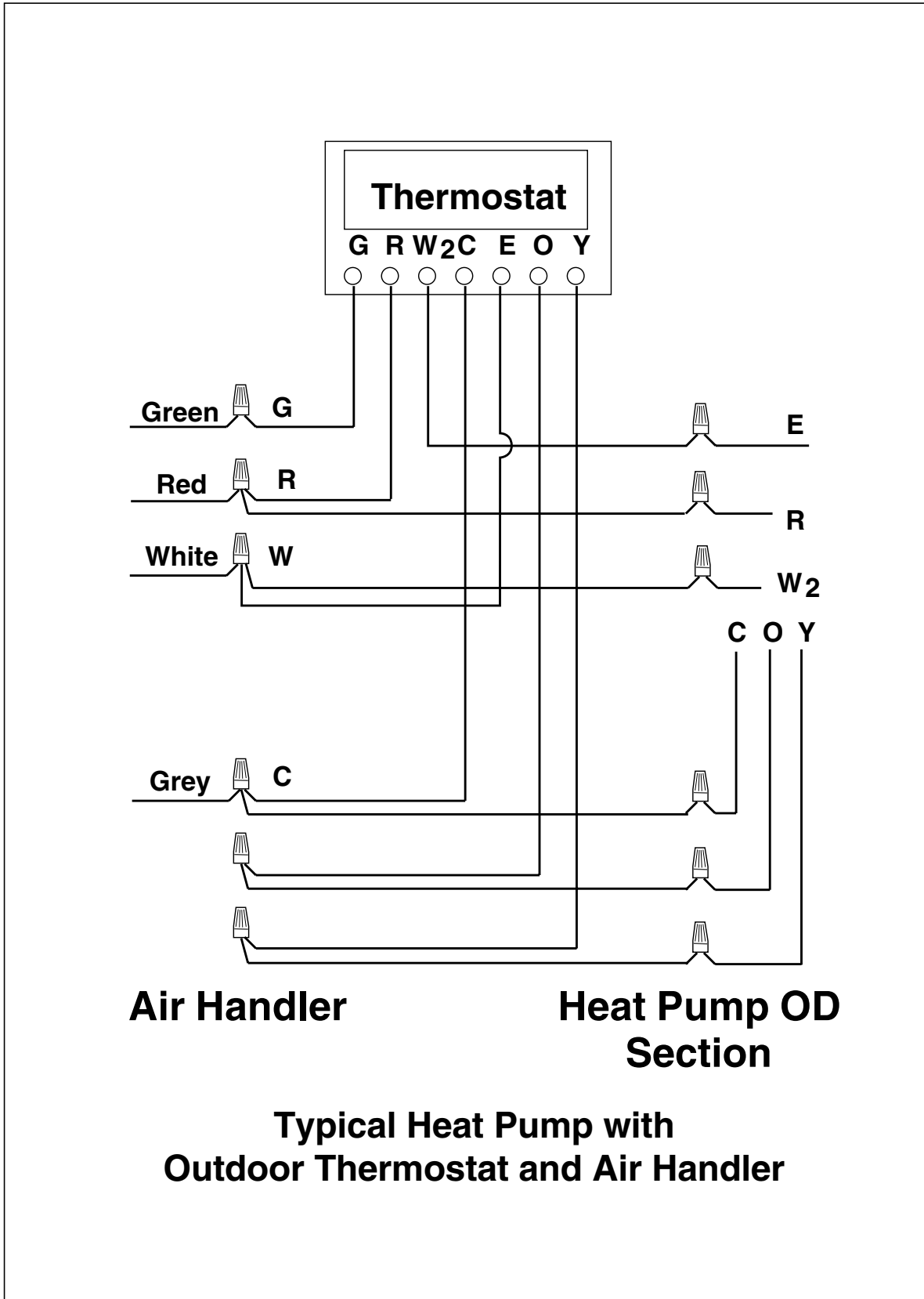

Using extreme caution, apply power to the unit and inspect the wiring for evidence of open, shorted, and/or improperly wired circuits.

Functional Checkout:

 **CAUTION:**

If equipped with a compressor crankcase heater, wait 24 hours prior to performing a function checkout to allow for heating of the compressor crankcase. Failure to comply may result in damage and could cause premature failure of the system.

Indoor Blower — Set the thermostat function switch to COOLING and the fan switch to ON. Verify that the indoor blower is operating and that airflow is not restricted. Set the fan switch back to AUTO.

Low-Pressure Switch — A low-pressure switch is factory-installed in select models only. If provided, this switch is located in the suction line internal to the outdoor unit. The switch is designed to protect the compressor from a loss of charge. Under normal conditions, the switch is closed. If the suction pressure falls below 5 psig, then the switch will open and de-energize the outdoor unit. The switch will close again once the suction pressure increases above 20 psig. Please note that the switch interrupts the thermostat inputs to the unit. Thus, when the switch opens and then closes, there will be a 5 minute short cycling delay before the outdoor unit will energize.

Cooling — Gradually lower the thermostat temperature setpoint below the actual room temperature and observe that the outdoor unit and indoor blower energize. Feel the air being circulated by the indoor blower and verify that it is cooler than ambient temperature. Listen for any unusual noises. If present, locate and determine the source of the noise and correct as necessary.

Short Cycle Protection — With the system operating in COOLING mode, note the setpoint temperature setting of the thermostat, and gradually raise the setpoint temperature until

the outdoor unit and indoor blower de-energize. Immediately lower the setpoint temperature of the thermostat to its original setting and verify that the indoor blower is energized and that the outdoor unit remains de-energized. Verify that, after approximately 5 minutes, the outdoor unit energizes and that the temperature of the air supplied to the facility is cooler than ambient temperature.

Heating — Lower the thermostat setpoint temperature to the lowest obtainable setting and set the thermostat function switch to HEATING. The indoor blower and outdoor unit should stop running. After a minimum of five minutes, increase the setpoint temperature of the thermostat to the maximum setting. Verify that the outdoor unit and indoor blower have energized. Feel the air being circulated by the indoor blower and verify that it is warmer than ambient temperature. Listen for any unusual noises. If present, locate and determine the source of the noise and correct as necessary.

OUTDOOR THERMOSTAT (if supplied)

The outdoor thermostat prevents the electrical auxiliary heat (if used) from operating above a desired set point. Selection of the set point is determined from the building design heat load.

The thermostat is adjustable from 45°F to 0°F. The factory temperature setting is at 40°F.

Defrost Cycle Timer — The defrost cycle timer controls the time interval of the hot gas defrost after the defrost sensor closes. It is located in the lower left corner of the defrost control board. Three interval settings are available: 30 minutes, 60 minutes, and 90 minutes. Time setting selection is dependent on the climate where the unit is being installed.

Example 1. Dry climate of Southern Arizona. A 90 minute setting is recommended.

Example 2. Moist climate of Seattle, Washington. A 30 minute setting is recommended.

To set the cycle timer, place the timing pin on the defrost control board to the desired time interval post.

Note: All units are shipped from the factory with the default time setting of 30 minutes. Maximum heating performance can be achieved by setting the time to 90 minutes.

Defrost Test Procedure

1. Terminals “R”-“C” must have 18-30v present between them in order for time delay and defrost sequences to be initiated.
2. With compressor running in heat mode, first jump the “T2”-“DFT” test pins. This will indicate to board that defrost T-stat is closed. Defrost T-stat closes at 32°, opens at 68°.
3. Next jump the “Test” pin to “C” on terminal strip. This will initiate defrost test in 5, 10 or 15 seconds (This is determined by 30, 60 or 90 minutes defrost pin settings). Factory setting will be 30 minutes.
4. When the reversing valve shifts to the defrost mode, quickly remove jumper from “Test”-“C”. If the jumper is not removed within a 5 second period, the defrost test will terminate. Unit will continue to stay in defrost mode Until :
 - A) Board recognizes that defrost sensor has reached 68° and opened or
 - B) “T2”-“DFT” jumper is removed or
 - C) 10 minutes have elapsed (board override)

If the above steps will not initiate a defrost, replace the defrost board.

Anti Short Cycle Timer Test

The 5 minute time delay feature can be bypassed or shortened to 1 second by jumping the “Test” to “C” terminal.

Note: If jumper is left on the “Test” to “common” pins permanently, the defrost cycle will become inoperable.

Optional Equipment — A functional checkout should be performed in accordance with the checkout procedures supplied with the equipment.

Adjustment of Refrigerant Charge:



CAUTION:

Split system heat pump equipment contains liquid and gaseous refrigerant under pressure. Adjustment of refrigerant charge should only be attempted by qualified, trained personnel thoroughly familiar with the equipment. Under no circumstances should the homeowner attempt to install and/or service this equipment. Failure to comply with this warning could result in equipment damage, personal injury, or death.

NOTE: The following Refrigerant Charging Charts are applicable to listed assemblies of equipment and at listed airflows for the indoor coil. Assemblies of indoor coils and outdoor units not listed are not recommended.

13 SEER SPLIT SYSTEM HEAT PUMP ORIFICE USAGE

Model Number	Restrictor Bore Size (in.)		System Charge R-22 (oz.)
	Indoor	Outdoor	
2 Ton	.065	.051	128
2-1/2 Ton	.069	.055	149
3 Ton	.077	.061	160
3-1/2 Ton	.080	.065	238
4 Ton	.090	.067	260

Refrigerant Charging Charts for Cooling Mode of Operation 13 SEER Split System Cooling Charts

REFRIGERANT CHARGING CHARTS LEGEND FOR COOLING/HEATING MODES OF OPERATION

*Note: All pressures are listed in psig. and all temperatures in deg. F.

- Shaded boxes indicate flooded conditions

- Rated design values. Suction Pressure will be lower than design value if indoor air flow, entering dry bulb, or entering wet bulb temperatures are lower than design.

- Discharge temperatures greater than charted values indicates a refrigerant undercharge.

2 TON	OUTDOOR TEMPERATURE (deg. F)																	
	70		75		80		85		90		95		100		105			
	Liq. Press.	Dis. Temp.	Liq. Press.	Dis. Temp.	Liq. Press.	Dis. Temp.	Liq. Press.	Dis. Temp.	Liq. Press.	Dis. Temp.	Liq. Press.	Dis. Temp.	Liq. Press.	Dis. Temp.	Liq. Press.	Dis. Temp.		
71																		
73	139	143																
75	141	155	153	143														
77	142	166	156	153	167	143												
79	142	191	158	163	170	151	144	139										
81	142	208	158	184	171	164	150	146	195	146	205	139						
83			159	198	173	178	160	154	199	154	209	145	219	139				
85					175	191	172	164	201	164	213	152	223	145	233	139		
87							187	173	203	173	216	161	228	151	237	145		
89								183	205	183	218	171	230	160	242	151		
91											220	181	233	169	245	159		
93													235	179	247	168		
95															250	177		
97																		

Refrigerant Charging Charts for Cooling Mode of Operation
13 SEER Split System Cooling Charts

2 1/2 TON	OUTDOOR TEMPERATURE (deg. F)																	
	70		75		80		85		90		95		100		105			
	Liq. Press.	Dis. Temp.	Liq. Press.	Dis. Temp.	Liq. Press.	Dis. Temp.	Liq. Press.	Dis. Temp.	Liq. Press.	Dis. Temp.	Liq. Press.	Dis. Temp.	Liq. Press.	Dis. Temp.	Liq. Press.	Dis. Temp.		
Suc. Press.																		
70																		
72	141	135																
74	142	147	154	139														
76	144	158	156	149	168	142												
78	144	177	159	159	171	151	183	145	193	142								
80	144	194	159	176	173	161	186	151	197	149	208	144						
82			161	190	175	174	188	160	201	158	212	150	222	145				
84					176	188	190	172	203	167	216	157	227	151	237	147		
86							192	187	205	175	218	166	231	157	242	152		
88									207	186	220	176	233	167	246	158		
90											223	186	235	176	248	168		
92													238	186	251	177		
94															253	186		
96																		

Refrigerant Charging Charts for Cooling Mode of Operation
13 SEER Split System Cooling Charts

3 TON		OUTDOOR TEMPERATURE (deg. F)																								
		70		75		80		85		90		95		100		105										
		Liq. Press.	Dis. Temp.	Liq. Press.	Dis. Temp.	Liq. Press.	Dis. Temp.	Liq. Press.	Dis. Temp.	Liq. Press.	Dis. Temp.	Liq. Press.	Dis. Temp.	Liq. Press.	Dis. Temp.	Liq. Press.	Dis. Temp.									
70																										
72	145	128																								
74	147	139	159	134																						
76	148	150	161	144	173	139																				
78	149	165	163	154	176	147	188	144	200	142																
80	150	182	165	168	179	156	192	150	203	150	215	145														
82			166	182	180	170	194	157	207	158	219	152	230	148												
84					182	183	196	170	210	167	223	158	235	154	246	150										
86							198	184	212	175	225	167	239	160	251	156										
88									214	186	228	177	241	170	255	162										
90											230	187	243	179	257	173										
92													246	189	259	182										
94															262	191										
96																										

**Refrigerant Charging Charts for Cooling Mode of Operation
13 SEER Split System Cooling Charts**

3 1/2 TON		OUTDOOR TEMPERATURE (deg. F)																							
		70		75		80		85		90		95		100		105									
		Liq. Press.	Dis. Temp.	Liq. Press.	Dis. Temp.	Liq. Press.	Dis. Temp.	Liq. Press.	Dis. Temp.	Liq. Press.	Dis. Temp.	Liq. Press.	Dis. Temp.	Liq. Press.	Dis. Temp.	Liq. Press.	Dis. Temp.								
71	135	117																							
73	137	128	149	125																					
75	138	140	151	135	163	131																			
77	140	151	153	145	166	140	178	136																	
79	140	166	155	155	169	148	181	143	193	140															
81			157	168	171	158	185	151	197	147	209	143													
83					173	171	187	161	201	154	213	150	225	146											
85							189	172	203	164	217	156	229	152	241	148									
87									205	174	219	166	234	158	246	154									
89											222	176	236	168	251	160									
91											224	186	238	178	252	170									
93													240	187	254	179									
95															257	188									
97																									

**Refrigerant Charging Charts for Cooling Mode of Operation
13 SEER Split System Cooling Charts**

4 TON	OUTDOOR TEMPERATURE (deg. F)																	
	70		75		80		85		90		95		100		105			
	Liq. Press.	Dis. Temp.	Liq. Press.	Dis. Temp.	Liq. Press.	Dis. Temp.	Liq. Press.	Dis. Temp.	Liq. Press.	Dis. Temp.	Liq. Press.	Dis. Temp.	Liq. Press.	Dis. Temp.	Liq. Press.	Dis. Temp.		
68	138	127																
70	140	138	152	134														
72	141	150	154	144	166	139												
74	143	161	156	154	169	148	180	144										
76	143	179	158	164	171	157	184	152	195	148								
78			159	179	174	168	187	160	199	155	210	152						
80					175	180	189	170	203	163	215	158	226	155				
82							191	182	205	173	219	165	230	161	241	157		
84									207	183	221	175	235	167	246	163		
86											223	185	237	177	251	169		
88											225	195	239	186	252	179		
90													241	196	255	188		
92															257	197		
94																		

Refrigerant Charging Charts for Heating Mode of Operation 13 SEER Split System Heating Charts

024K																											
OUTDOOR TEMPERATURE (DEG. F)																											
0				10				20				30				40				50				60			
Suc. Press.	Liquid Press.	Disch. Temp.	Suc. Press.	Liquid Press.	Disch. Temp.	Suc. Press.	Liquid Press.	Disch. Temp.	Suc. Press.	Liquid Press.	Disch. Temp.	Suc. Press.	Liquid Press.	Disch. Temp.	Suc. Press.	Liquid Press.	Disch. Temp.	Suc. Press.	Liquid Press.	Disch. Temp.	Suc. Press.	Liquid Press.	Disch. Temp.	Suc. Press.	Liquid Press.	Disch. Temp.	
10	113	103	20	130	108	30	148	113	41	166	118	51	174	128	61	194	142	72	214	156							
11	120	101	21	136	106	31	153	111	42	170	116	52	181	125	62	201	138	73	221	150							
12	127	99	22	142	104	32	158	109	43	173	114	53	188	122	63	208	133	74	228	144							
13	134	97	23	148	102	33	163	107	44	177	112	54	195	120	64	215	129	75	235	138							
14	141	95	24	154	100	34	167	105	45	181	110	55	202	117	65	222	124	76	242	132							
15	148	93	25	160	98	35	172	103	46	184	108	56	209	114	66	229	120	77	249	125							
16	155	91	26	166	96	36	177	101	47	188	106	57	216	111	67	236	115	78	256	119							

030K																											
OUTDOOR TEMPERATURE (DEG. F)																											
0				10				20				30				40				50				60			
Suc. Press.	Liquid Press.	Disch. Temp.	Suc. Press.	Liquid Press.	Disch. Temp.	Suc. Press.	Liquid Press.	Disch. Temp.	Suc. Press.	Liquid Press.	Disch. Temp.	Suc. Press.	Liquid Press.	Disch. Temp.	Suc. Press.	Liquid Press.	Disch. Temp.	Suc. Press.	Liquid Press.	Disch. Temp.	Suc. Press.	Liquid Press.	Disch. Temp.	Suc. Press.	Liquid Press.	Disch. Temp.	
13	115	117	22	132	120	31	149	123	40	167	126	49	171	135	58	187	148	67	202	162							
14	122	115	23	138	118	32	154	121	41	170	124	50	178	132	59	194	144	68	209	155							
15	129	113	24	144	116	33	159	119	42	174	122	51	185	129	60	201	139	69	216	149							
16	136	111	25	150	114	34	164	117	43	178	120	52	192	126	61	208	135	70	223	143							
17	143	109	26	156	112	35	168	115	44	181	118	53	199	123	62	215	130	71	230	137							
18	150	107	27	161	110	36	173	113	45	185	116	54	206	121	63	222	126	72	237	131							
19	157	105	28	167	108	37	178	111	46	189	114	55	213	118	64	229	121	73	244	125							

Refrigerant Charging Charts for Heating Mode of Operation 13 SEER Split System Heating Charts

OUTDOOR TEMPERATURE (DEG. F)																						
036K																						
	0			10			20			30			40			50			60			
	Suc. Press.	Liquid Press.	Disch. Temp.	Suc. Press.	Liquid Press.	Disch. Temp.	Suc. Press.	Liquid Press.	Disch. Temp.	Suc. Press.	Liquid Press.	Disch. Temp.	Suc. Press.	Liquid Press.	Disch. Temp.	Suc. Press.	Liquid Press.	Disch. Temp.	Suc. Press.	Liquid Press.	Disch. Temp.	
13	114	120	22	131	122	31	149	124	40	166	126	49	172	132	58	190	143	68	207	153		
14	121	118	23	137	120	32	154	122	41	170	124	50	179	130	59	197	138	69	214	147		
15	128	116	24	143	118	33	158	120	42	174	122	51	186	127	60	204	134	70	221	140		
16	135	114	25	149	116	34	163	118	43	177	120	52	193	124	61	211	129	71	228	134		
17	142	112	26	155	114	35	168	116	44	181	118	53	200	121	62	218	125	72	235	128		
18	149	110	27	161	112	36	173	114	45	185	116	54	207	118	63	225	120	73	242	122		
19	156	108	28	167	110	37	177	112	46	188	114	55	214	115	64	232	116	74	249	116		

OUTDOOR TEMPERATURE (DEG. F)																						
042K																						
	0			10			20			30			40			50			60			
	Suc. Press.	Liquid Press.	Disch. Temp.	Suc. Press.	Liquid Press.	Disch. Temp.	Suc. Press.	Liquid Press.	Disch. Temp.	Suc. Press.	Liquid Press.	Disch. Temp.	Suc. Press.	Liquid Press.	Disch. Temp.	Suc. Press.	Liquid Press.	Disch. Temp.	Suc. Press.	Liquid Press.	Disch. Temp.	
15	116	116	23	131	117	31	145	119	40	159	120	50	165	129	63	186	145	75	207	160		
16	123	114	24	137	115	32	150	117	41	163	118	51	172	126	64	193	140	76	214	154		
17	130	112	25	142	113	33	154	115	42	166	116	52	179	123	65	200	136	77	221	148		
18	137	110	26	148	111	34	159	113	43	170	114	53	186	120	66	207	131	78	228	142		
19	144	108	27	154	109	35	164	111	44	174	112	54	193	117	67	214	127	79	235	136		
20	151	106	28	160	107	36	169	109	45	177	110	55	200	115	68	221	122	80	242	130		
21	158	104	29	166	105	37	174	107	46	181	108	56	207	112	69	228	118	81	249	123		

**Refrigerant Charging Charts for Heating Mode of Operation
13 SEER Split System Heating Charts**

048K		OUTDOOR TEMPERATURE (DEG. F)																						
		0			10			20			30			40			50			60				
Suc. Press.	Liquid Press.	Disch. Temp.	Suc. Press.	Liquid Press.	Disch. Temp.	Suc. Press.	Liquid Press.	Disch. Temp.	Suc. Press.	Liquid Press.	Disch. Temp.	Suc. Press.	Liquid Press.	Disch. Temp.	Suc. Press.	Liquid Press.	Disch. Temp.	Suc. Press.	Liquid Press.	Disch. Temp.	Suc. Press.	Liquid Press.	Disch. Temp.	
12	116	118	21	136	123	31	155	127	40	174	132	49	182	139	60	203	150	70	224	161	80	245	172	161
13	123	116	22	141	121	32	159	125	41	177	130	50	189	137	61	210	146	71	231	155	81	252	166	155
14	130	114	23	147	119	33	164	123	42	181	128	51	196	134	62	217	141	72	238	148	82	263	177	148
15	137	112	24	153	117	34	169	121	43	185	126	52	203	131	63	224	137	73	245	142	83	268	182	142
16	144	110	25	159	115	35	174	119	44	188	124	53	210	128	64	231	132	74	252	136	84	271	187	136
17	151	108	26	165	113	36	178	117	45	192	122	54	217	125	65	238	128	75	259	130	85	274	192	130
18	158	106	27	171	111	37	183	115	46	196	120	55	224	122	66	245	123	76	266	124	86	277	197	124

**INSTALLER: PLEASE LEAVE
THESE INSTALLATION
INSTRUCTIONS WITH THE
HOMEOWNER.**



7081630



7081630 (Replaces 707829B)

Specifications and illustrations subject to change
without notice and without incurring obligations.
Printed in U.S.A. (06/02)