

Residential Gas Furnaces

Installation Instructions

*RC 92+ Upflow Condensing Furnace

*RL 90+ Downflow Condensing Furnace

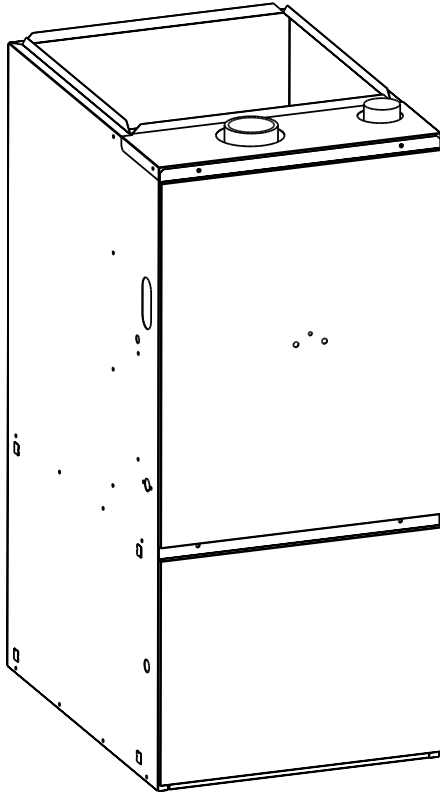

*RC 92+ Upflow

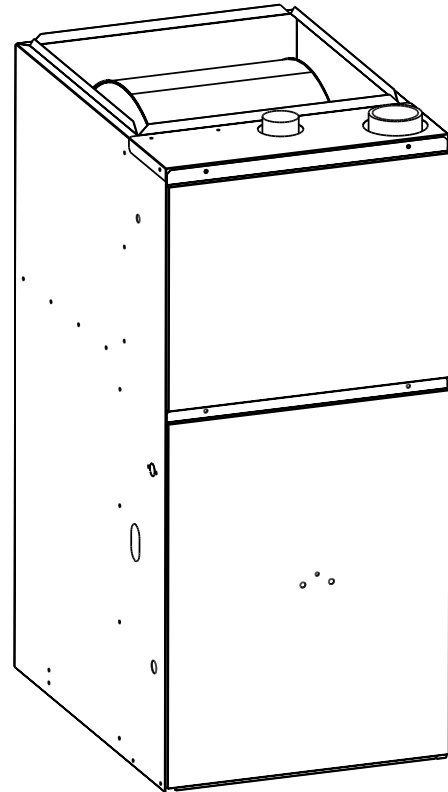

*RL 90+ Downflow

WARNING:

Improper installation, adjustment, alteration, service, or maintenance can cause injury or property damage. Refer to this manual for assistance. For additional information consult a qualified installer, service agency, or the gas supplier.

These instructions are primarily intended to assist qualified individuals experienced in the proper installation of this appliance. Some local codes require licensed installation/service personnel for this type of equipment. Read all instructions carefully before starting the installation.

DO NOT DESTROY. PLEASE READ CAREFULLY AND KEEP IN A SAFE PLACE FOR FUTURE REFERENCE.

FOR YOUR SAFETY:

Do not store or use gasoline or other flammable vapors and liquids in the vicinity of this or any other appliance.

FOR YOUR SAFETY:

WHAT TO DO IF YOU SMELL GAS:

- Do not try to light any appliance.
 - Do not touch any electrical switch; do not use any phone in your building.
 - Immediately call your gas supplier from a neighbor's phone. Follow the gas supplier's instructions.
 - If you cannot reach your gas supplier, call the fire department.
 - Extinguish any open flame.
-

Table of Contents

Furnace Specifications	4-5
Furnace Airflow Data	6-7
Safety Information	8
Installation Requirements	8
Supply Air Plenum Installation	10
Installation on a Concrete Slab	10
Installation on a Combustible Floor	10
Circulating Air Supply	10
Return Air	12
Venting and Combustion Air Requirements	12
Air Requirements for One-Pipe Installation	14
Installation in An Unconfined Space	14
Installation in A Confined Space	14
• Air From Inside	15
• Air Directly Through An Exterior Wall	15
• Outdoor Air Through Vertical Openings or Ducts	15
• Outdoor Air Through Horizontal Openings or Ducts	15
Venting Requirements	15
Vent Pipe Material	16
Vent Pipe Length and Diameter	16
Vent Pipe Installation	17
Pipe Routing & Support	17
Location of Outdoor Terminations	18
Horizontal Venting	18
Vertical Venting	21
Vent Freezing Protection	22
Concentric Vent Termination	22
Drainage of Condensate From Furnace	23
Gas Supply and Piping	24
Leak Check	24
Conversion	24
High Altitude Application	26
Natural Gas High Altitude Conversion	26
LP/Propane Gas Sea Level and High Altitude Conversion	26
Electrical Wiring	27
Line Voltage Wiring	27
Low Voltage Wiring	27
Start-up and Adjustments	27
Start-Up Procedure	28
Verifying and Adjusting Firing Rate	28
Verifying and Adjusting Temperature Rise	29
Verifying Burner Operation	29
Verifying Operation of the Supply Air Limit Switch	30
Description of Components	30
Maintenance	31
Combustion Air and Vent System	31
Air Filter(s)	31
Lubrication	31
Condensate Drain Assembly	31
Blower Compartment	31
Heat Exchanger and Burner Maintenance	31
Location of Major Components	33
System Operation Information	31
Sequence of Operation	34
Furnace Fails to Operate	35
Twinning of Two Furnaces	35
Installation/Performance Checklist	Back Page

FURNACE SPECIFICATIONS

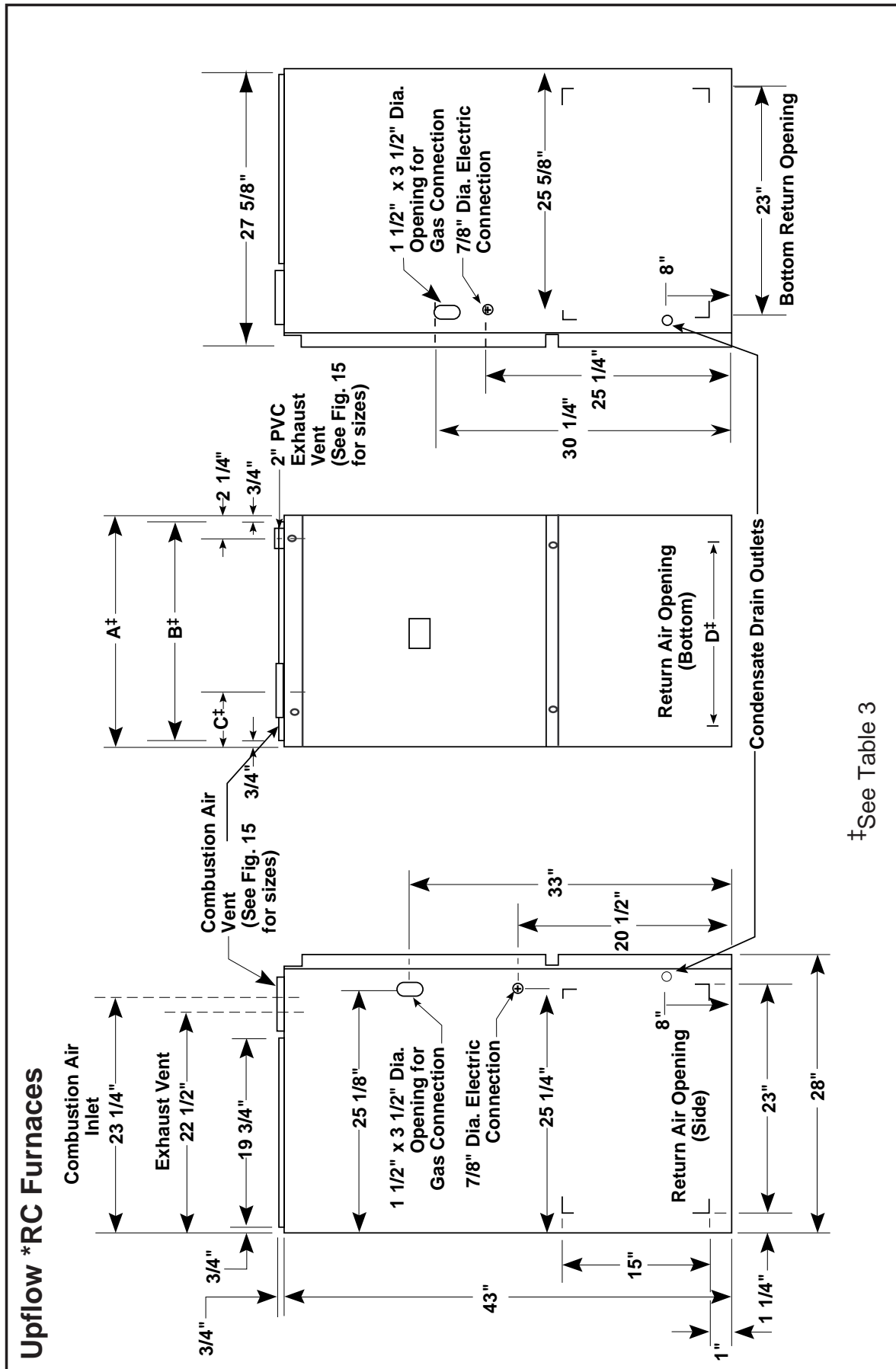

Figure 1. Upflow Unit Dimensions

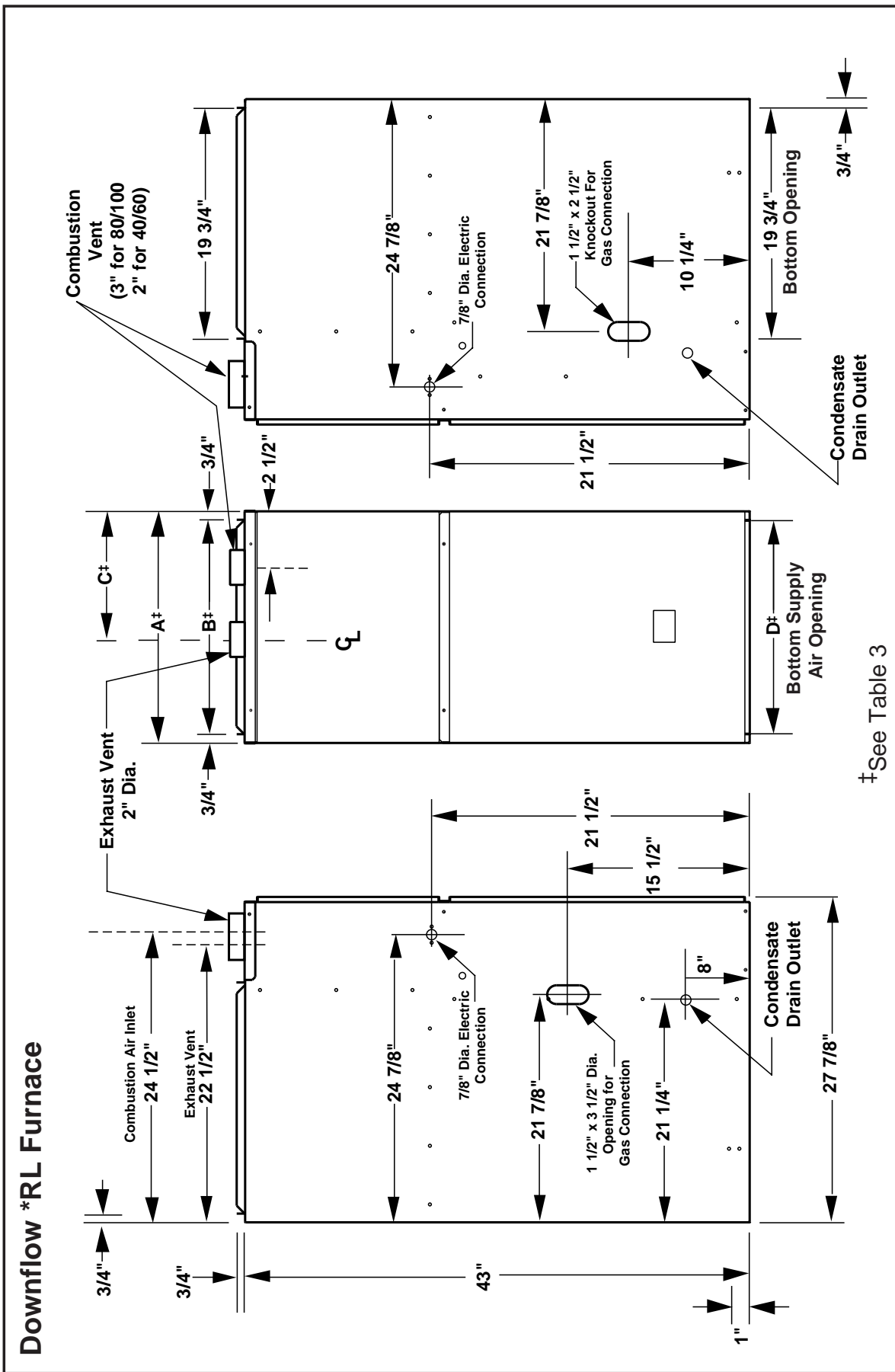

Figure 2. Downflow Unit Dimensions

CAPACITIES —Furnace Airflow Data

Model Number *RC-	Heating Input (Btuh)	Motor Speed	Motor HP	External Static Pressure (Inches Water Column)																											
				0.1			0.2			0.3			0.4			0.5			0.6			0.7			0.8						
				CFM	Rise		CFM	Rise		CFM	Rise		CFM	Rise		CFM	Rise		CFM	Rise		CFM	Rise		CFM	Rise					
040C-08	40,000	High* Medium Low**	1/5	950	36	920	38	890	39	850	41	800	43	750	46	690	50	630	55	550	58	490	63	430	63	350	63	290	63		
040C-12	40,000	High* Medium Low**	1/3	1330	-	1280	-	1230	-	1170	-	1120	-	1030	-	940	37	850	41	780	44	760	46	720	48	670	52	610	57	550	63
060C-12	60,000	High* Medium Low**	1/3	1310	-	1260	-	1210	-	1160	45	1100	47	1040	50	980	53	920	56	800	65	780	67	710	73	680	-	650	-	620	-
080C-12	80,000	High* Medium Low**	1/3	1490	46	1450	48	1390	50	1310	53	1210	57	1100	63	980	-	830	-	780	-	720	-	630	-	570	-	510	-	440	-
080C-16	80,000	High* Med-High Med-Low** Low	1/2	1840	-	1780	-	1700	41	1630	42	1550	45	1470	47	1380	50	1290	54	1150	60	1080	64	1010	69	910	-	810	-	680	-
100C-16	100,000	High* Med-High** Med-Low Low	1/2	1600	43	1560	44	1470	47	1400	49	1350	51	1280	54	1210	57	1150	60	1060	67	960	67	900	67	800	-	750	-	750	-
120C-16	120,000	High* Med-High** Med-Low Low	1/2	1910	45	1860	47	1780	49	1700	51	1620	53	1520	57	1420	61	1310	66	1150	75	1060	69	1000	69	960	-	880	-	880	-
120C-20	120,000	High* Med-High Med-Low** Low	3/4	2260	-	2200	-	2140	-	2070	-	1990	-	1910	-	1810	57	1710	61	1560	67	1430	71	1370	76	1300	80	1220	85	1150	-

NOTES: 1. Airflow rates of 1800 CFM or more require two return air connections. Data is for operation with filter(s).
 2. Temperature rises in the table are approximate. Actual temperature rises may vary.
 3. Temperature rises and airflows for external static pressures greater than 0.5 are for reference only.
 These conditions are not recommended.

* Factory Set Cooling Speed
 ** Factory Set Heating Speed
 - Not Recommended

Table 1. Furnace Airflow Data

CAPACITIES —Furnace Airflow Data continued

Model Number *RL-	Heating Input (Btuh)	Motor Speed	Motor HP	External Static Pressure (Inches Water Column)																											
				0.1			0.2			0.3			0.4			0.5			0.6			0.7			0.8						
				CFM	Rise		CFM	Rise		CFM	Rise		CFM	Rise		CFM	Rise		CFM	Rise		CFM	Rise		CFM	Rise					
040C-12	40,000	High*	1/3	1280	-	1210	-	1180	-	1140	-	1090	-	1070	-	1030	-	990	-	1140	-	1030	-	1090	-	1070	-	1030	-	990	-
		Medium		1140	-	1090	-	1060	-	1030	-	980	-	950	-	910	-	870	-	1030	-	950	-	980	-	950	-	910	-	870	-
		Low**		875	39	835	41	820	41	805	42	780	43	770	44	760	45	750	45	805	42	780	43	780	43	770	44	760	45	750	45
060C-12	60,000	High*	1/3	1260	40	1190	43	1155	44	1120	45	1075	47	1030	49	940	54	1120	45	1040	49	1075	47	1030	49	980	52	940	54		
		Medium		1120	45	1070	48	1040	49	1010	50	960	53	930	55	890	60	1010	50	960	53	960	53	930	55	890	60				
		Low**		855	59	815	62	800	64	780	65	760	67	730	70	710	-	690	-	780	65	760	67	760	67	730	70	710	-	690	-
080C-16	80,000	High*	1/2	1635	-	1585	-	1525	-	1460	46	1400	48	1330	51	1260	54	1460	46	1300	52	1255	54	1200	56	1150	59	1090	62		
		Med-High		1435	47	1395	49	1350	50	1300	52	1255	54	1200	56	1150	59	1300	52	1255	54	1255	54	1200	56	1150	59	1090	62		
		Med-Low**		1230	55	1200	56	1165	58	1130	60	1090	62	1050	65	1000	68	960	71	1130	60	1090	62	1090	62	1050	65	1000	68	960	71
100C-16	100,000	High*	1/2	1600	53	1555	54	1500	56	1445	59	1380	61	1310	65	1240	68	1445	59	1335	63	1290	66	1240	68	1190	71	1130	75		
		Med-High**		1475	57	1435	59	1385	61	1335	63	1290	66	1240	68	1190	71	1335	63	1290	66	1290	66	1240	68	1190	71	1130	75		
		Med-Low		1320	-	1290	-	1250	-	1215	-	1170	-	1120	-	1070	-	1020	-	1215	-	1170	-	1170	-	1120	-	1070	-	1020	-
		Low		1150	-	1130	-	1110	-	1075	-	1040	-	1000	-	950	-	1075	-	1040	-	1040	-	1000	-	950	-	890	-		

- NOTES: 1. Airflow rates of 1800 CFM or more require two return air connections. Data is for operation with filter(s).
 2. Temperature rises in the table are approximate. Actual temperature rises may vary.
 3. Temperature rises and airflows for external static pressures greater than 0.5 are for reference only.
 These conditions are not recommended.

* Factory Set Cooling Speed
 ** Factory Set Heating Speed
 - Not Recommended

Table 2. Furnace Airflow Data

SAFETY INFORMATION

1. Use only with type of gas approved for this furnace. Refer to the furnace rating plate.
2. Install this furnace only in a location and position as specified on Table 4 of these instructions.
3. Provide adequate combustion and ventilation air to the furnace space as specified on Pages 12 through 17.
4. Provide adequate clearances around the vent air intake terminal(s) as specified on Figures 17 through 20 of these instructions.
5. Combustion products must be discharged outdoors. Connect this furnace to an approved vent system only, as specified on Pages 15 through 22.
6. Never test for gas leaks with an open flame. Use a commercially available soap solution made specifically for the detection of leaks to check all connections, as specified on Page 24 of these instructions.
7. Always install furnace to operate within the furnace's intended temperature-rise range with a duct system which has an external static pressure within the allowable range, as specified on Table 2 of these instructions. See furnace rating plate.
8. When a furnace is installed so that supply ducts carry air circulated by the furnace to areas outside the space containing the furnace, the return air shall also be handled by duct(s) sealed to the furnace casing and terminating outside the space containing the furnace.
9. A gas-fired furnace for installation in a residential garage must be installed as specified on Page 10 of these instructions.
10. The furnace is not to be used for temporary heating of buildings or structures under construction.

INSTALLATION REQUIREMENTS

Requirements and Codes

This furnace must be installed in accordance with these instructions, all applicable local building codes, and the current revision of the National Fuel Gas Code (ANSI-Z223.1, NFPA-54). The current revision of the National Fuel Gas Code is available from:

American National Standards Institute, Inc.
1430 Broadway
New York, New York 10018

Canada installations shall comply with CAN/CGA-B149 installation codes, local plumbing or waste water codes and other applicable codes. Additional helpful publications are:

- NFPA-90A - Installation of Air Conditioning and Ventilating Systems.
- NFPA-90B - Warm Air Heating and Air Conditioning Systems.

These publications are available from:
National Fire Protection Association, Inc.
Batterymarch Park
Quincy, Massachusetts 02269



WARNING:

This furnace is not approved for installation in mobile homes. Installation in a mobile home could cause fire, property damage, and/or personal injury.

Location

The furnace must be installed on a level surface, and as close to the center of the air distribution system as possible. See Table 3 for overall dimensions to determine the required clearances in hallways, doorways, stairs, etc. to allow the furnace to be moved to the installation point. The furnace must be installed so that all electrical components are protected from water. Minimum clearances to combustible materials are listed in Table 4. Access for positioning and servicing must be considered when locating the unit. 24 inches is the minimum required clearance for servicing the unit. 30 inches is the minimum required clearance for positioning the unit. 36 inches is the recommended clearance from the front of the unit. Please note that a panel or door can be located such that the minimum clearance on the rating plate is satisfied, but that panel or door must be removable and allow the appropriate clearance for your installation.

This furnace is certified for use on wood flooring. The furnace must be installed on a solid surface and must be level front to back and side to side. This furnace must not be installed directly on carpeting, tile, or any combustible material other than wood flooring.

Model Number	Furnace Btuh	Dimensions (inches)				Shipping Weight (lbs)
		A	B	C	D	
*RC040C	40,000	14 1/4	12 3/4	5 1/8	11 3/4	133
*RC060C	60,000	14 1/4	12 3/4	5 1/8	11 3/4	140
*RC080C	80,000	19 3/4	18 1/4	7 7/8	17 1/4	172
*RC100C	100,000	19 3/4	18 1/4	7 7/8	17 1/4	180
*RC120C	120,000	22 1/2	21	9 1/4	20	204
*RL040C	40,000	14 1/4	12 3/4	4 5/8	12 3/4	135
*RL060C	60,000	14 1/4	12 3/4	4 5/8	12 3/4	135
*RL080C	80,000	19 3/4	18 1/4	10	18 1/4	174
*RL100C	100,000	19 3/4	18 1/4	10	18 1/4	185

Table 3. Furnace Dimensions and Shipping Weights

CLEARANCES TO COMBUSTIBLE MATERIALS

This furnace is Designed Certified by CSA International for the minimum clearances to combustible material listed in Table 4. See the furnace name plate, located inside the furnace cabinet, for specific model number and clearance information.

MINIMUM CLEARANCES TO COMBUSTIBLE MATERIAL						
Furnace Input (Btuh)	Cabinet Width (Inches)	Minimum Clearances (Inches)				
		Side	Vent	Back	Top	Front
40,000	14 1/4	0	0	0	1	1*
60,000	14 1/4	0	0	0	1	1*
80,000	14 1/4	0	0	0	1	1*
100,000	19 3/4	0	0	0	1	1*
120,000	22 1/2	0	0	0	1	1*

Table 4. Minimum Clearances to Combustible Materials

DOWNFLOW WARNING

(*RL Models):

The design of the downflow furnace is certified for natural or propane gas and for installation on non-combustible flooring. A special combustible floor sub-base is required when installing on a combustible floor. Failure to install the sub-base may result in fire, property damage and personal injury. The special downflow sub-bases are factory supplied accessories, part numbers 902677 and 902974. When the furnace is installed on a factory or site-built cased air conditioning coil, the sub-base is not necessary. However, the plenum attached to the coil casing must be installed such that its surfaces are at least 1" from combustible construction.

A gas-fired furnace installed in a residential garage must be installed so that the bottom of the furnace is located a minimum of 18" from the floor. The furnace must be located or protected to avoid physical damage by vehicles.

HORIZONTAL INSTALLATIONS

The upflow model furnaces are approved for horizontal installation. Installation Kit #903568 is required for horizontal applications. Follow the installation instructions in the kit for proper conversion. NOTE: The downflow models are NOT approved for horizontal installation.

SUPPLY AIR PLENUM INSTALLATION

A. Installation on a concrete slab - *RL

1. Construct a hole in the floor per the dimensions in Figure 3.
2. Place the plenum and the furnace as shown in Figure 4.

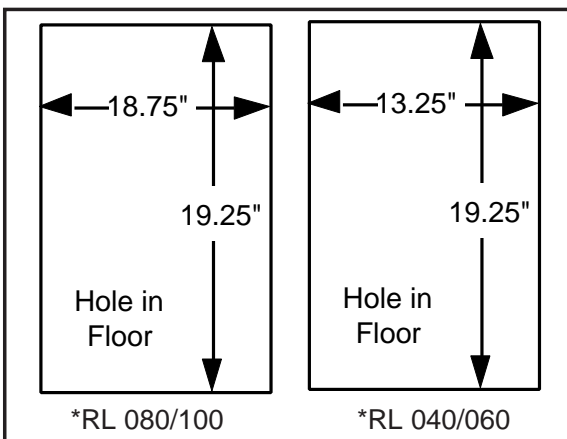

Figure 3. Opening for Concrete Slab

B. Installation on a combustible floor - *RL

1. Cut and frame the hole in the floor per the dimensions in Figure 5.
2. Place the sub-base for combustible floors over the hole with its duct collar extended downward. Attach the supply air plenum to the base in a manner which will ensure 1" clearance to the flooring or other combustible material. Place furnace on the combustible base as shown in Figure 6.
3. When the furnace is installed on a factory or site-built cased air conditioning coil, the sub-base is not necessary. However, the plenum attached to the coil casing must be installed such that its surfaces are at least 1" from combustible material.

CIRCULATING AIR SUPPLY

Plenums and air ducts must be installed in accordance with the Standard for the Installation of Air Conditioning and Ventilating Systems (NFPA No. 90A) or the Standard for the Installa-

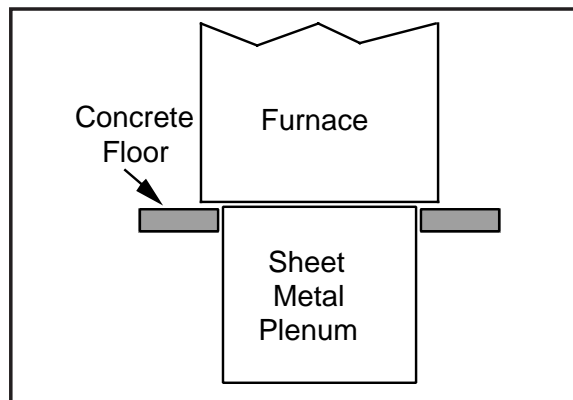

Figure 4. Furnace on a Concrete Slab

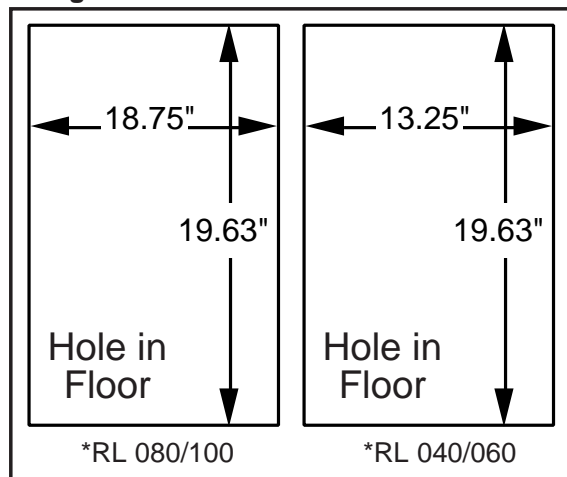

Figure 5. Opening in Wood Floor

tion of Warm Air Heating and Air Conditioning Systems (NFPA No. 90B).

If outside air is utilized as return air to the furnace for ventilation or to improve indoor air quality, the system must be designed so that the return air to the furnace is not less than 50°F (10°C) during heating operation. If a combination of indoor and outdoor air is used, the ducts and damper system must be designed so that the return air supply to the furnace is equal to the return air supply under normal, indoor return air applications.

When a cooling system is installed which uses the furnace blower to provide airflow over the indoor coil, the coil must be installed downstream (on the outlet side) or in parallel with the furnace.

If a cooling system is installed in parallel with the furnace, a damper must be installed to prevent chilled air from entering the furnace and condensing on the heat exchanger. If a manually operated damper is installed, it must be designed so that operation of the furnace is prevented when the damper is in the cooling position and operation of the cooling system is prevented when the damper is in the heating position.

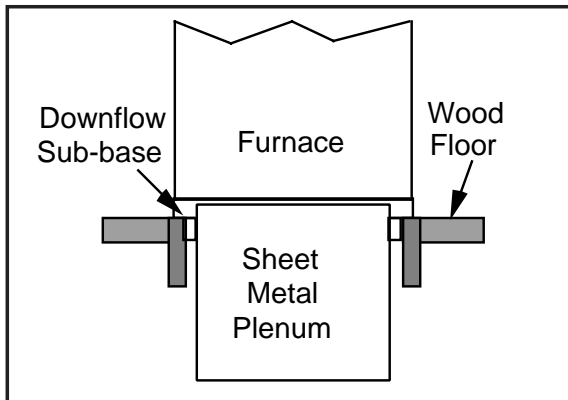

Figure 6. Furnace on a Wood Floor

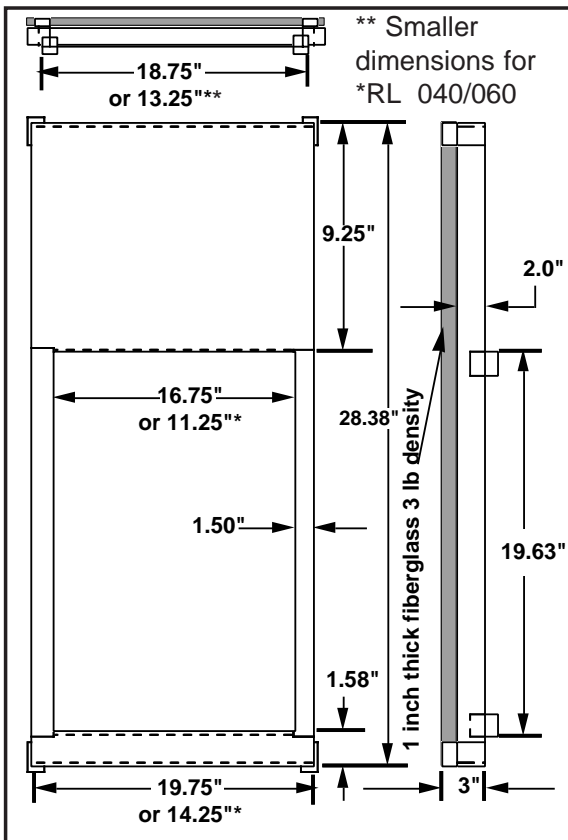

Figure 7. Downflow Sub-Base Dimensions

! WARNING:

Products of combustion must not be allowed to enter the return air ductwork or the circulating air supply. Failure to prevent products of combustion from being circulated into the living space can create potentially hazardous conditions including carbon monoxide poisoning that could result in personal injury or death.

All return ductwork must be secured to the furnace with sheet metal screws. For installations in confined spaces, all return ductwork must be adequately sealed and joints must be taped. When return air is provided through the bottom of the furnace, the joint between the furnace and the return air plenum must be sealed.

The floor or platform on which the furnace is mounted must provide sound physical support of the furnace with no gaps, cracks, or sagging between the furnace and the floor or platform.

Return air and circulating air ductwork must not be connected to any other heat producing device such as a fireplace insert, stove, etc.

Return Air

The return air ductwork may be connected to any or all of the following: left side return, right side return, or bottom return. Tables 1 and 2 show the airflow data for each furnace model. **Where maximum airflow is 1800 CFM or more two openings must be used.**

VENTING AND COMBUSTION AIR REQUIREMENTS

NORDYNE condensing furnaces may be installed with outdoor combustion air piped directly to the furnace, or without such special piping. Codes refer to the former as “direct vent” or “two pipe” installation. Installation with air taken from around the furnace is sometimes referred to as “one pipe” installation - i.e. only the vent (exhaust) pipe is provided.

Provisions must be made for adequate supply of air for combustion and ventilation. For United States installations, the adequacy of air provisions can be determined by consulting the current version of the National Fuel Gas Code (ANSI Z223.1/NPFA-54). For Canadian installations, requirements are specified in the National Standard of Canada (CAN/CGA B149.1 & .2). Consult local codes for special requirements.

An important consideration in selecting one or two pipe installation is the quality of the combustion air. Indoor air is sometimes contaminated with various household chemicals which can cause severe corrosion in the furnace combustion system.

NOTE: If the furnace is operated without adequate air for combustion and ventilation, it may not perform properly. Furnace components may be strained by high temperature and could fail .

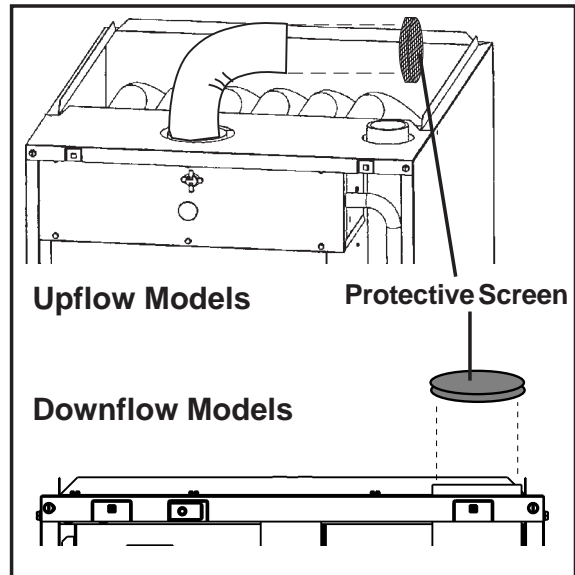

Figure 8. Protective Screen for One Pipe Installations

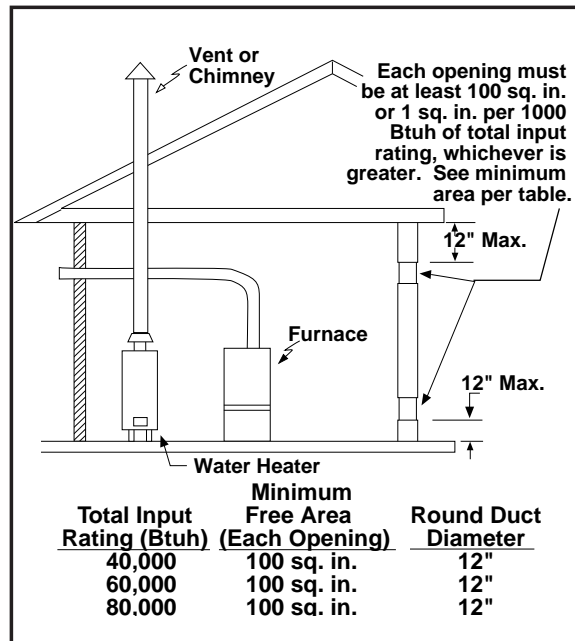

Figure 9. Equipment in a Confined Space with all Combustion Air drawn from Inside

WARNING:

Furnace installation using methods other than those described in the following sections must comply with the National Fuel Gas Code and all applicable local codes to provide sufficient combustion air for the furnace.

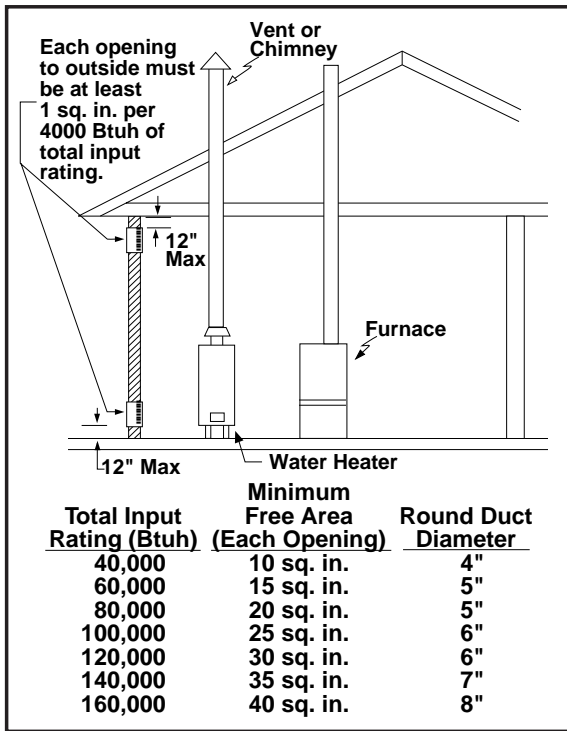

Figure 10. Equipment in a Confined Space with all Combustion Air drawn from Outdoors through Exterior Wall

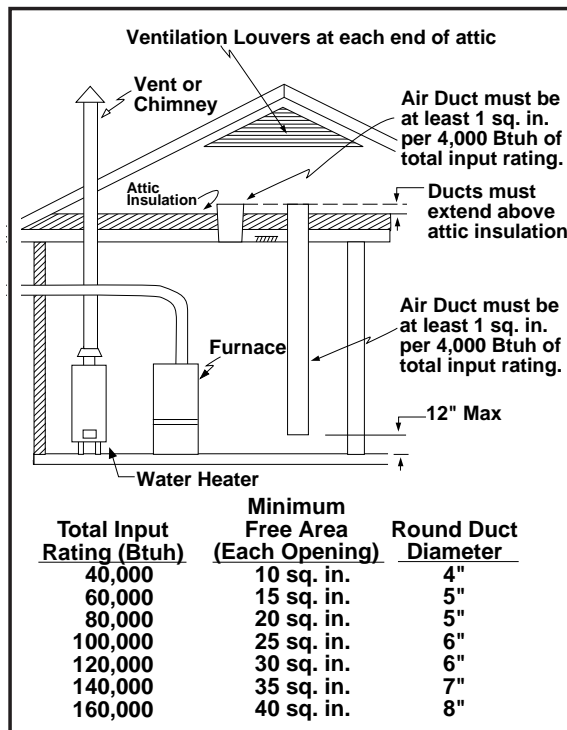

Figure 11. Equipment in a Confined Space with all Combustion Air drawn from Outdoors through Vertical Ducts – from Ventilated Attic

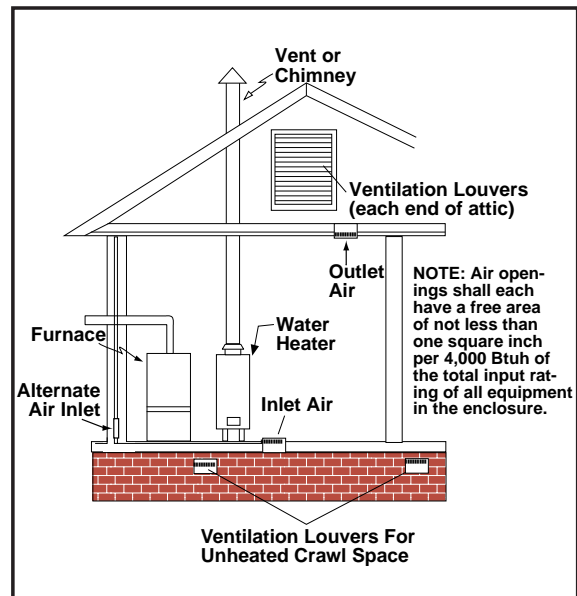

Figure 12. Equipment in a Confined Space with all Combustion Air drawn from Outdoors through Ventilated Crawl Space and Ventilated Attic

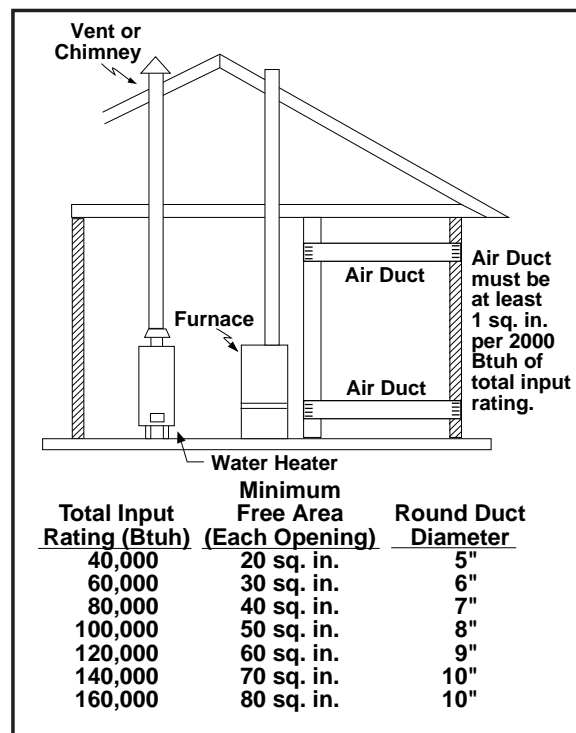

Figure 13. Equipment in a Confined Space with all Combustion Air Drawn from the Outside through Horizontal Ducts

Combustion Air Quality

The recommended source of combustion air is to use the outdoor air supply. However, the use of indoor air in most applications is acceptable except as follows:

1. If the furnace is installed in a confined space it is recommended that the necessary combustion air come from the outdoors by way of attic, crawl space, air duct, or direct opening.
2. If outdoor combustion air is used, there must be no exposure to the installations or substances listed in Item 3 below.
3. The following types of installation may require **Outdoor Air** for combustion, due to chemical exposures:
 - Commercial buildings
 - Buildings with indoor pools
 - Furnaces installed in laundry rooms
 - Furnaces installed in hobby or craft rooms
 - Furnaces installed near chemical storage areas

Exposure to the following substances in the combustion air supply may also require **Outdoor Air** for combustion:

- Permanent wave solutions
- Chlorinated waxes and cleaners
- Chlorine based swimming pool chemicals
- Water softening chemicals
- De-icing salts or chemicals
- Carbon tetrachloride
- Halogen type refrigerants
- Cleaning solvents (such as perchloroethylene)
- Printing inks, paint removers, varnishes, etc.
- Hydrochloric acid
- Cements and glues
- Antistatic fabric softeners for clothes dryers
- Masonry acid washing materials

Air Requirements For One-Pipe Installation

When air for combustion is to be taken from around the furnace, a protective screen must be installed over the combustion air intake opening. This screen is provided with the furnace installation instructions and functions to prevent debris from entering the combustion system. It should be installed on the combustion air intake

collar or inlet PVC. If furnace location is such that this opening might be unintentionally obstructed, a 3" PVC elbow should be installed on the collar, and the screen placed inside the inlet of the elbow. See Figure 8.

Installation In An Unconfined Space

CAUTION:

“Tight” buildings (with weather stripping and caulk to reduce infiltration), may require special provisions for introduction of outside air to ensure satisfactory combustion and venting, even though the furnace is located in an unconfined space.

An unconfined space is an area including all rooms not separated by doors with a volume greater than 50 cubic feet per 1,000 Btuh of the combined input rates of all appliances which draw combustion air from that space. For example, a space including a water heater rated at 45,000 Btuh and a furnace rated at 75,000 Btuh requires a volume of 6,000 cubic feet [$50 \times (45 + 75) = 6,000$] to be considered unconfined. If the space has an 8 foot ceiling, the floor area of the space must be 750 square feet ($6,000 / 8 = 750$). In general, a furnace installed in an unconfined space will not require outside air for combustion.

WARNING:

Furnaces installed with combustion air drawn from a heated space which includes exhaust fans, fireplaces, or other devices that may produce a negative pressure should be considered confined space installations.

Installation In A Confined Space

A confined space is one which does not meet the unconfined space volume requirements, and typically involves installation in a small room. All such installations must have specific provisions for introduction of combustion and ventilation air. *Codes require that two openings be provided for this - one with bottom edge within 12" of the floor and one with top edge within 12" of the ceiling.* The size and other criteria for these openings must be per the following sections.

Combustion air openings must not be restricted in any manner.

Furnaces installed in a confined space which supply circulating air to areas outside of the space must draw return air from outside the space and must have return air ducts tightly sealed to the furnace.

Air From Inside

Air for combustion and ventilation may be taken from inside the building through an interior wall *if the building is not "tight" and if the total volume of the furnace space and the space from which air is drawn meets the volume requirements for an unconfined space.* In such cases, the two openings in the wall must each have free area of at least one square inch per 1000 Btuh of *total* appliance input, but not less than 100 square inches of free area. See Figure 9. For example, if the combined input rate of all appliances is less than or equal to 100,000 Btuh, *each* opening must have a free area of at least 100 square inches. If the combined input rate of all appliances is 120,000 Btuh, *each* opening must have a free area of at least 120 square inches.

Air Directly Through An Exterior Wall

If combustion air is provided directly through an exterior wall, the two openings must *each* have free area of at least one square inch per 4000 Btuh of *total* appliance input. (See Figure 10.)

Outdoor Air Through Vertical Openings or Ducts

If combustion air is provided through vertical ducts or openings to attics or crawl spaces, the two openings must each have free area of at least one square inch per 4000 Btuh of total appliance input. Ducts must have cross-sectional areas at least as large as the free area of their respective openings to the furnace space. Attics or crawl spaces must communicate freely with the outdoors if they are the source of air for combustion and ventilation. (See Figures 11 and 12.)

Outdoor Air Through Horizontal Openings or Ducts

If combustion air is taken from outdoors through horizontal ducts, the openings must *each* have free area of at least one square inch per 2000 Btuh of total appliance input. Ducts must have cross-sectional area at least as large as the free

area of their respective openings to the furnace space. (See Figure 13.)

**CAUTION:**

Do not supply combustion air from an attic space that is equipped with power ventilation or any other device that may produce a negative pressure.

VENTING REQUIREMENTS

This section specifies installation requirements for vent and "2-pipe" combustion air piping. For "one pipe" installations, install vent piping per this section and provide air for combustion and ventilation per the previous section. The capacity table provided in this section applies to the total of vent and combustion air piping for either type of installation.

NORDYNE condensing furnaces are classified as "Category IV" appliances, which require special venting materials and installation procedures. Category IV appliances operate with positive vent pressure and therefore require vent systems which are thoroughly sealed. They also produce combustion condensate, which is slightly acidic and can cause severe corrosion of ordinary venting materials. Furnace operation can be adversely affected by restrictive vent and combustion air piping. Therefore, *vent and combustion air piping lengths must conform completely to the requirements of Table 5.*

The furnace must be vented to the outdoors. It must not be vented in common with any other appliance, even if that appliance is of the condensing type. Common venting can result in severe corrosion of other appliances or their venting and can allow combustion gases to escape through such appliances or vents. Do not vent the furnace to a fireplace chimney or building chase.

**WARNING:**

FURNACE MUST NOT BE COMMON VENTED WITH OTHER APPLIANCES.

Vent Pipe Material

Vent and combustion air pipe and fittings must be one of the following materials and must conform to the indicated ANSI/ASTM standards:

Material	Standard
Schedule 40 PVC	D1785
PVC-DWV	D2665
SDR-21*	D2241
& SDR-26*	
ABS-DWV	D2661
Schedule 40 ABS	F628
Foam/Cellular Core PVC	F891

*In Canada, check the local codes to ensure that SDR is approved for use. SDR is not approved for all Canadian installations.

Cement and primer must conform to ATSM Standard D2564 for PVC and Standard D2235 for ABS. When joining PVC piping to ABS, use PVC solvent cement. (See procedure specified in ASTM Standard D3138.)

Vent Pipe Length and Diameter

In order for the furnace to operate properly, the combustion air and vent piping must not be excessively restrictive. To ensure this use Table 5, which indicates the maximum allowable piping length for a furnace of specified input rate, when installed with piping of selected diameter and number of elbows. This table applies to the length and number of elbows for each pipe. To

use the table, the furnace input rate, the centerline length and the number of elbows on each pipe must be known. Choose the diameter for which the tabulated length is equal to or greater than required.

Proper use of the table is illustrated by the following example:

Example:

An 80,000 Btu/h furnace is to be installed in a "one-pipe" system with 40 feet of vent piping. There are a total of four long radius 90-degree elbows used in the vent, including the one exterior to the building.

Solution:

For this particular installation, the equivalent vent length must be calculated. This equivalent vent length will then be compared to the maximum allowable vent length given in Table 5. Then, the diameter of the piping can be chosen for which the equivalent vent length is less than the maximum allowable vent length. Returning to our example, we consult Table 5 and determine that for an 80,000 Btu/h furnace the maximum vent length for 2" diameter piping is 60 feet or for 3" diameter piping is 150 feet. Note that the maximum vent length given in Table 5 includes one long radius elbow. Therefore, for our example, we have three additional long radius elbows for which we must add to our piping. Each long radius elbow is equivalent to 2.5 feet, so we must add 7.5 feet to our vent length.

APPLICATION PVC, CPVC or ABS SCH. 40 Pipe Size	SINGLE PIPE LENGTH (ft.) with 1 long radius elbow**		DIRECT VENT, DUAL PIPE LENGTH (ft.) with 1 long radius elbow on each pipe**					
	Outlet 2"	Outlet 3"	Inlet/Outlet 2" 2"		Inlet/Outlet 3" 2"		Inlet/Outlet 3" 3"	
Models *R(C,L) 040	80	150	40	40	50	50	90	90
Models *R(C,L) 060 & 080	60	150	30	30	35	35	90	90
Models *R(C,L) 100 & 120	30	150	15	15	25	25	90	90

**NOTES

1. Subtract 2.5 ft. for each additional 2" **long** radius elbow, 5 ft. for each additional 2" **short** radius elbow, 3.5' for each additional 3" **long** radius elbow, and 7' for each additional 3" **short** radius elbow.
2. Two 45 degree elbows are equivalent to one 90 degree elbow.
3. Do not include termination elbows in calculation of vent length
4. This table is applicable for elevations from sea level to 2000 ft. For higher elevations decrease vent pipe lengths by 8% per 1000 ft. of altitude.
5. Only the above pipe materials are approved for use with these condensing furnaces.

Table 5. Vent Table

Therefore, the equivalent vent length for our installation is 47.5 feet. We compare this with the maximum vent length for 2" and 3" diameter piping. For both cases, our equivalent vent length is less than the maximum allowable vent length, so for our "one-pipe" installation we can use either 2" or 3" diameter piping.

Condensing furnace combustion products have very little buoyancy, so Table 5 is to be used without consideration of any vertical rise in the piping.

NOTE: Always use the same or larger size piping for combustion air as is used for the exhaust vent.

Vent Pipe Installation

Pipe Routing and Support

Route piping as directly as possible between the furnace and the outdoors and remember that routing affects pipe size requirements per the preceding section. If a two pipe system is used,

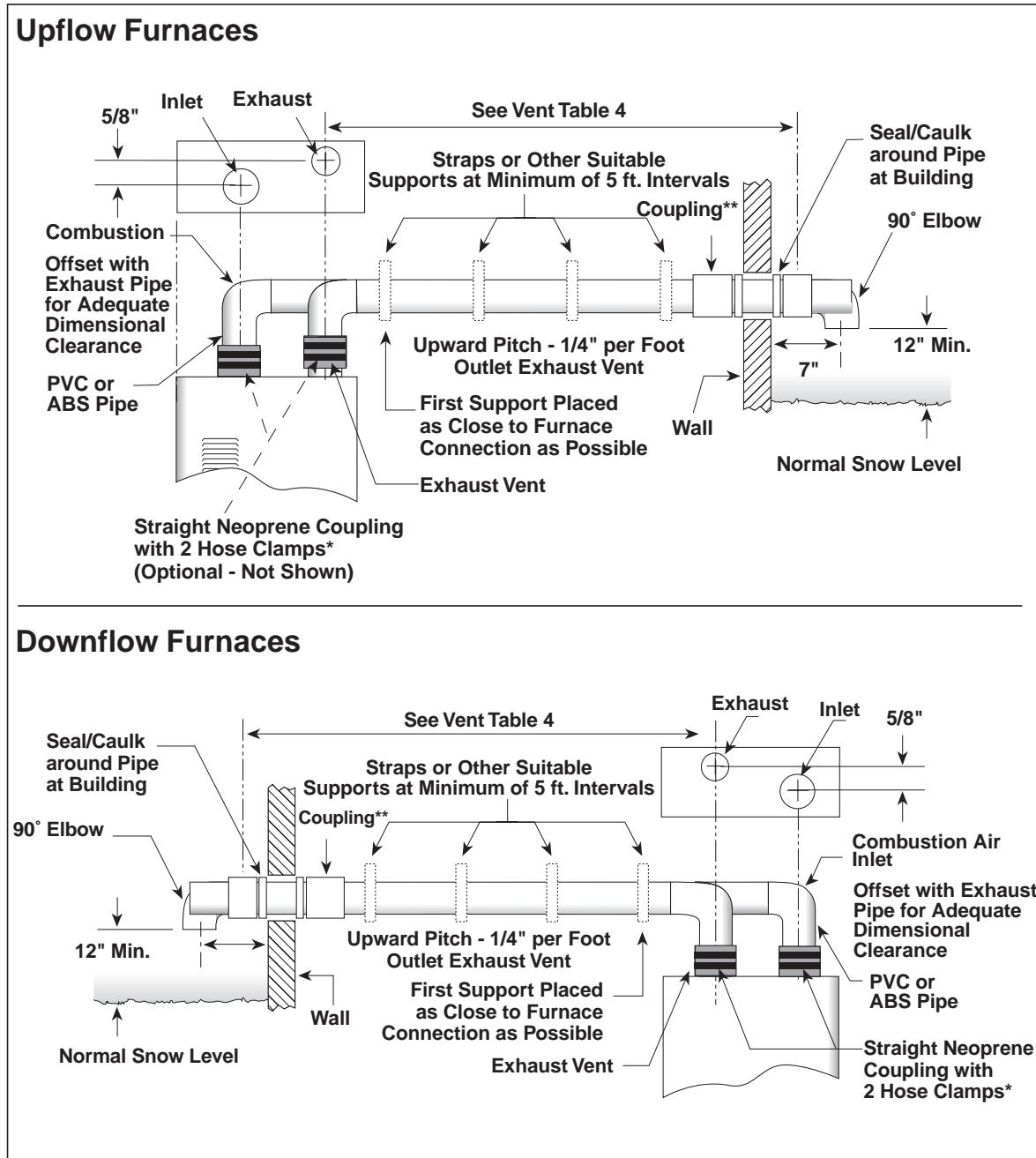

Figure 14. Horizontal Venting

* These neoprene couplings are field-supplied and can be used if the installation requires breakable connections in the piping. Note that a maximum of two couplings per pipe are allowed.

** Couplings are field supplied and are to be installed when required by local code.

locate the combustion air intake and the vent exhaust in the same atmospheric pressure zone - i.e. both must exit the building through the same portion of exterior wall or roof. Vent piping must be sloped upwards not less than 1/4" per foot in the direction from the furnace to the terminal. This is to ensure that any condensate flows back to the furnace (where it can be disposed of through the condensate disposal system).

The quality of outdoor air must also be considered. Be sure that the combustion air intake is not located near a source of solvent fumes or other chemicals which can cause corrosion of the furnace combustion system.

 **CAUTION:**

Combustion air must not be drawn from a corrosive atmosphere.

Piping must be mechanically supported so that its weight does not bear on the furnace. Supports must be at intervals no greater than five feet, and at smaller intervals if necessary to ensure that there are no sagging sections to trap water. (See Figures 14 and 15.) It is recommended to install couplings along the vent pipe, on either side of the exterior wall. These couplings may be required by local code.

Figure 16 illustrates vent and combustion air pipe sizes exiting the furnace. Transition to the correct pipe size must be done close to the furnace so that the full length of pipe is of proper size.

Straight neoprene couplings are supplied with the downflow furnaces only. These couplings are to be installed in the combustion air inlet (if present) and exhaust vent piping at the furnace as shown in Figures 13 and 14. For an upflow furnace installation, if breakable connections are required in the combustion air inlet (if present) and exhaust vent piping, then straight neoprene couplings for 2" or 3" piping with hose clamps can be used. These couplings can be ordered through your local furnace distributor.

To install a coupling, slide the rubber coupling over the end of the pipe that is attached to the furnace and secure it with one of the hose clamps. Then slide the other end of the rubber coupling onto the other pipe from the vent and secure the coupling with the second hose clamp.

Ensure that the connection is tight and leak free.

NORDYNE condensing furnaces have been certified for installation with zero clearance between vent piping and combustible surfaces. However, it is good practice to allow space for convenience in installation and service.

Location of Outdoor Terminations

Horizontal Venting

Vent and combustion air intake terminations must be as shown in Figure 19. Vent termination clearances shall be consistent with the National Fuel Gas Code, ANSI 2223.1/NFPA 54 and/or the CSA B149.1, Natural Gas and Propane Installation Code.

All minimum clearances specified must be maintained to protect building materials from degradation by flue gases.

 **WARNING:**

Ensure that the combustion air vent and the exhaust vent are configured as shown in Figure 19. Improper vent termination can cause recirculation of the flue gases. This may result in furnace vibration. In severe cases, the furnace will cycle due to the intermittent contact between the flame and the flame sensor. If you note oscillations occurring, check the vent configuration. Make sure that the exhaust vent does not have a 90 degree termination.

Vent and combustion air intake terminations must be located to ensure proper furnace operation and to conform to applicable codes. Figure 17 illustrates necessary distances from the vent termination to windows and building air intakes. **In Canada, the Canadian Fuel Gas Code takes precedence over these instructions. Specifically, all minimum distance requirements with respect to termination of the vent piping listed below (items 1 through 8).**

The following list is a summary of vent terminal location requirements:

1. The termination must be 12 inches above snow level or grade level whichever is higher. See Figure 18 for alternate method to achieve 12" above snow level.

Upflow Furnaces

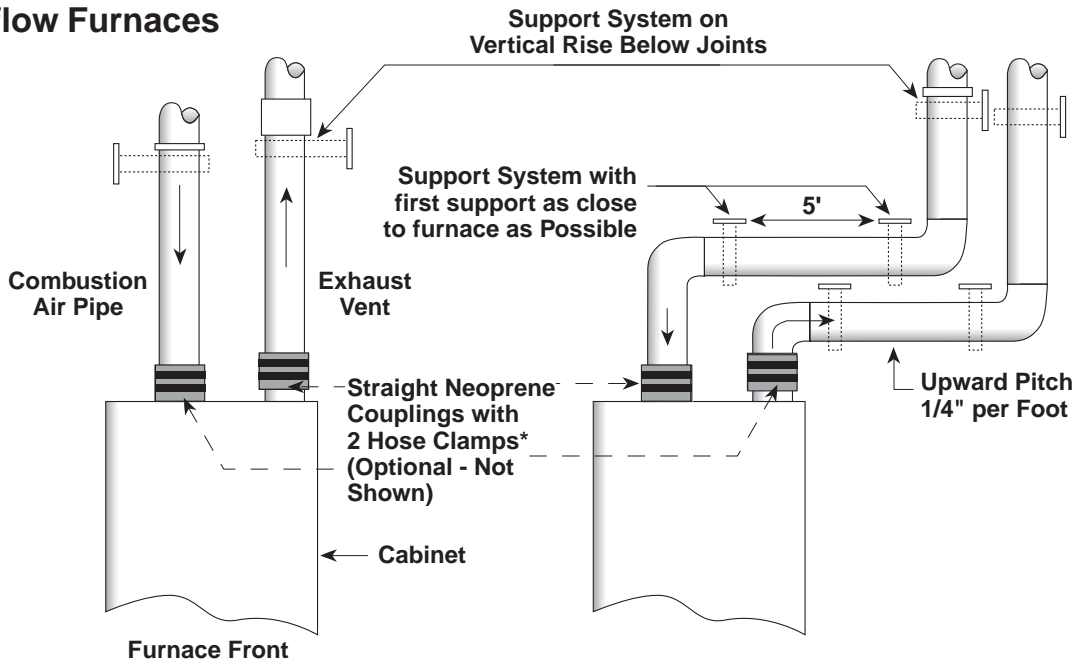

Downflow Furnaces

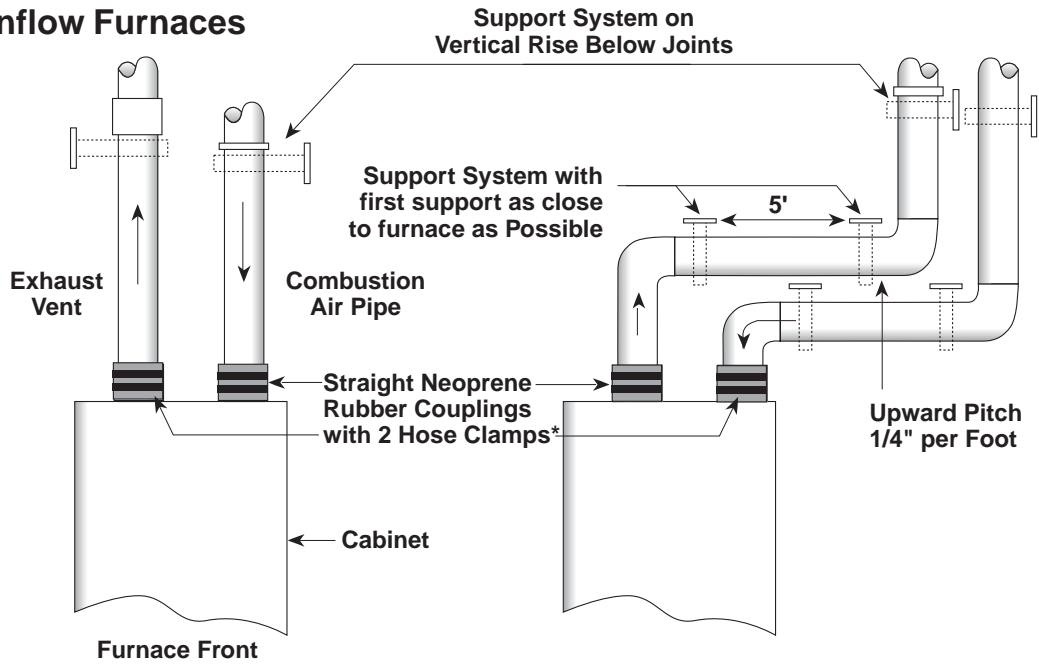

Figure 15. Vertical Venting

* These couplings are field-supplied and can be used if the installation requires breakable connections in the piping. Note that a maximum of two couplings per pipe are allowed.

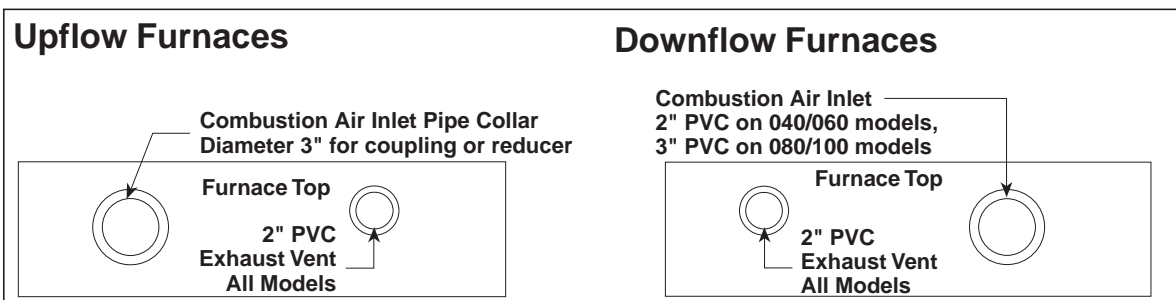

Figure 16. Furnace Pipe Adaptions

2. The minimum distance for a (1-pipe installation) from any door, (openable) window, or gravity air inlet is 4 ft. below, 4 ft. horizontally, or 1 ft. above.
3. The minimum distance for a direct vent (2-pipe) installation) from any door, (openable) window, or air gravity inlet is 1 ft. below, 1 ft. horizontally, or 1 ft. above.
4. For one-pipe installations the recommended minimum distance from an inside corner formed by two exterior walls is 6 feet, but is not required.
5. The vent termination for a 1-pipe installation shall be a minimum of 3 ft. above any forced air inlet within 10 ft.
6. The vent termination shall be located at least 4 ft. horizontally from any electric meter, gas meter, regulator and any relief equipment. These distances apply ONLY to U.S. installations. In Canada, the Canadian Fuel Gas Code takes precedence.
7. Avoid areas where condensate drainage may cause problems by dropping on planters or patios, etc. Also ensure that exhaust gases will not impinge on windows or building surfaces, which may be compromised or damaged by condensation. Do not install the vent terminal such that exhaust is directed into window wells, stairwells, under decks or into alcoves or similar recessed areas, and do not terminate above any public walkways.

8. Select the point of wall penetration where the minimum 1/4 inch per foot of slope up can be maintained.

! CAUTION:

For optimum performance, vent furnace through wall which experiences the least exposure to winter winds.

For horizontal venting, one of the following kits is recommended:

For Canadian installations please refer to the Canadian Installation Code (CAN/CGA-B149.1 or 2) and/or local codes.

The kit consists of two face plates and an insulating gasket to seal the exterior surface. A hole sized closely to the pipe diameter must first be cut through the wall. A short length of pipe is then cut such that it can penetrate the wall and be held in place by closely fitting standard couplings. The face plates are retained on both sides of the wall by the couplings, and the gasket is retained against the wall by the outer face plate. Face plates must be fastened to the wall and the outside one must be flashed as appropriate to prevent entry of water.

When the above kits are not used the following steps are required:

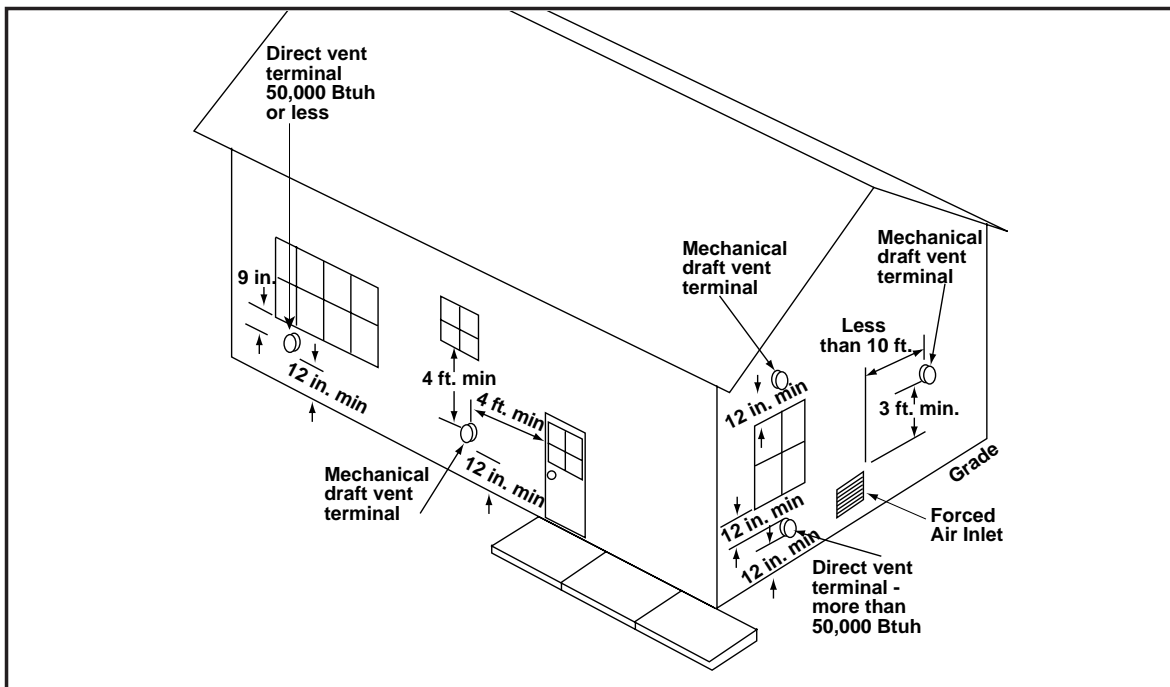

Figure 17. Vent Termination Clearances

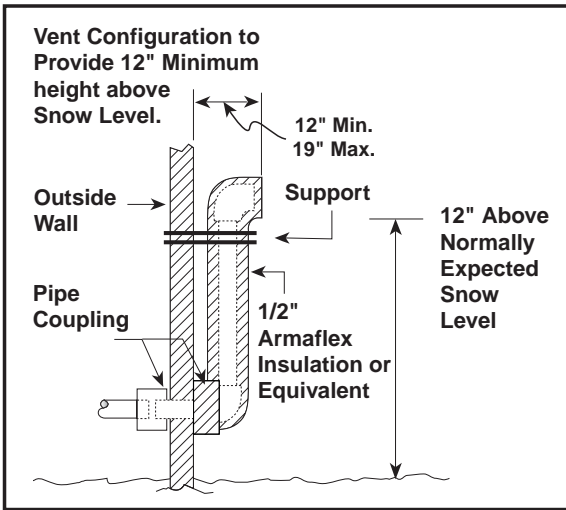

Figure 18. Alternate Horizontal Vent Installation

1. Check the hole size cut through the exterior wall. Insure that the hole diameter is less than the diameter of the couplings to be used.
2. Extend the vent pipe through the wall approximately 1" and seal the area between the wall and pipe.
3. Apply couplings to the vent pipe on the interior and exterior sides of the wall to insure the pipe can not be pushed or pulled through the wall.
4. Insure the combustion air inlet pipe (for a 2 pipe installation) has a 90 degree termination elbow as shown in Figures 19 and 20.

Note that a combustion air intake must be provided with an elbow opening downward. The screen provided with the furnace must be installed in the elbow to prevent entry of debris or creatures.

When the vent pipe must exit an exterior wall close to the grade or expected snow level, a riser should be provided as shown in Figure 18. Insulation is required to prevent freezing of this section of pipe.

Vertical Venting

Figure 20 shows the proper installation and clearances for vertical vent termination. The roof penetration must be properly flashed and waterproofed with a plumbing roof boot or equivalent flashing. Termination spacing requirements from the roof and from each other must be per Figure 20.

Vent and combustion air piping may be installed in an existing chimney which is not in use provided that:

- a. Both the exhaust vent and air intake run the length of the chimney.
- b. The top of the chimney is sealed and weatherproofed.
- c. The termination clearances shown in Figure 20 are maintained.
- d. No other gas fired or fuel-burning equipment is vented through the chimney.

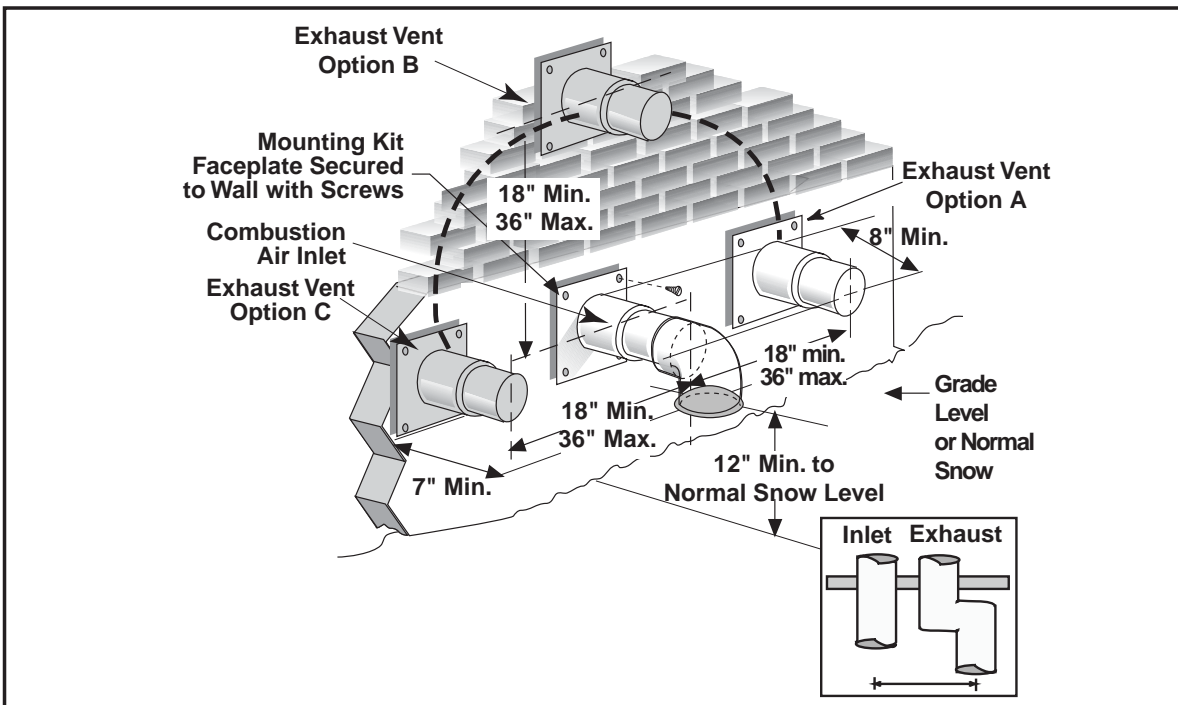

Figure 19. Exhaust and Combustion Air Pipe Clearances

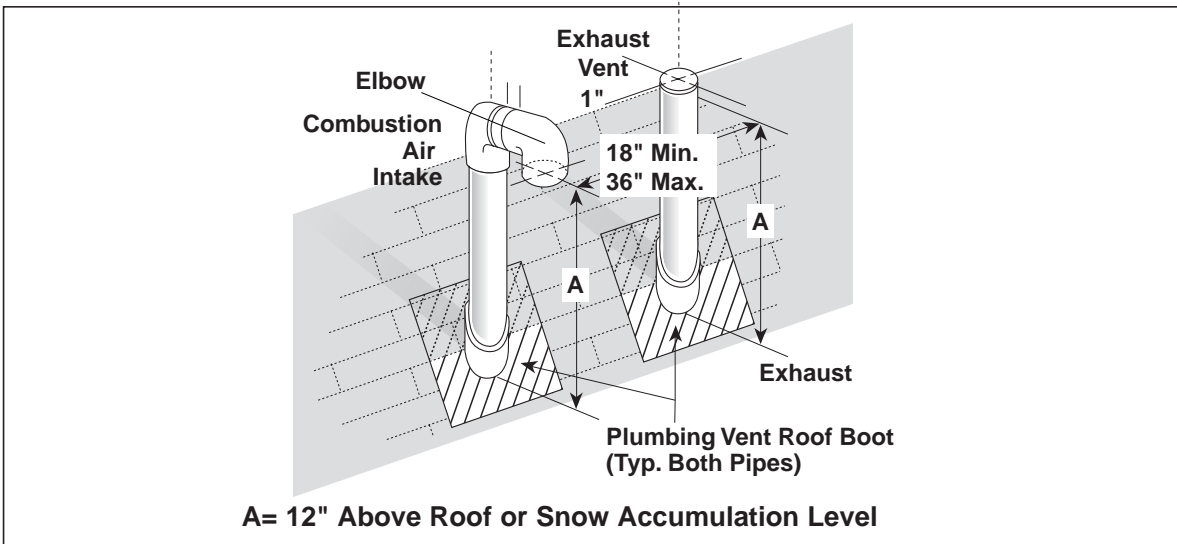

Figure 20. Vertical Vent Termination

Vent Freezing Protection

When the vent pipe is exposed to temperatures below freezing, i.e., when it passes through unheated spaces, chimneys, etc., the pipe must be insulated with 1/2 inch thick sponge rubber insulation, Armaflex-type insulation or equivalent. Insulating pipe is important to avoid condensate icing.

For extremely cold climates or for conditions of short furnace cycles (i.e. set back thermostat conditions) the last three feet of vent pipe can be reduced one nominal pipe size provided that the

total vent length is at least 15 feet in length and the vent is sized in accordance with the venting requirements (Table 5) before this reduction is applied. (Example: 3" to 2-1/2" or 2" to 1-1/2") Smaller vent pipes are less susceptible to freezing, but must not be excessively restrictive.

Concentric Vent Termination

A concentric vent termination is approved for use with these furnaces. The kit part number is 903578. For proper installation of the concentric vent termination, follow the installation instructions provided with that kit.

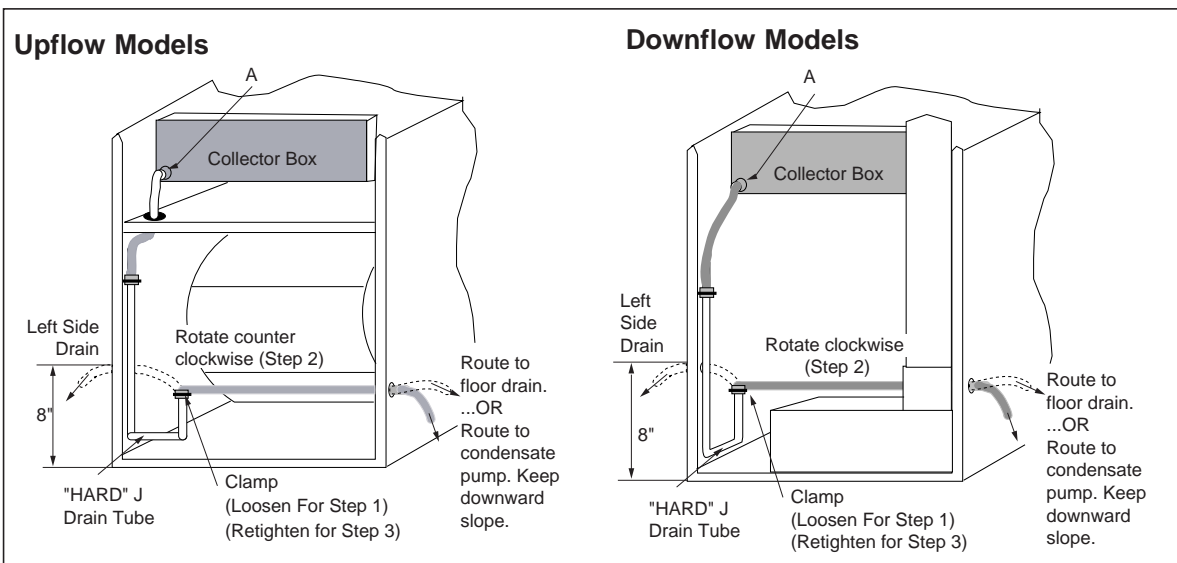

Figure 21. Furnace with Condensate Drain Trap Assembly

DRAINAGE OF CONDENSATE FROM FURNACE

WARNING:

The condensate produced by the furnace must be drained. Do not connect a water supply to the drainage hose of the furnace.

NOTE: The condensate drain should be protected from freezing when in unheated spaces.

The condensate drainage system is internal to the furnace. It is not recommended to connect additional traps to the exterior of the furnace. Doing so will have adverse effects on the operation of the furnace. The drain may exit either the right or left side of the furnace cabinet.

The condensate drain can be routed to a flow drain or to a condensate pump. Ensure that the drain maintains a downward slope from the unit to the drain. Refer to Figure 21 for more details.

For a right side drain simply extend the tubing out of the 7/8" hole in the cabinet, see Figure 21. For a left side drain follow the steps below:

1. Loosen the clamp on the soft exit tube (see Figure 21.)
2. Rotate the soft exit tube (counter clockwise, 180° upflow *RC models; clockwise 90° downflow *RL models.)

3. Re-tighten the clamp. **MAKE SURE CLAMP IS TIGHT TO AVOID LEAKAGE OF CONDENSATE.**
4. Route the tubing out of the 7/8" hole located 8 inches up from the bottom furnace.

The condensate should drain from the plastic collector box (location A in Figure 21) as droplets or a small stream. If you notice the furnace has operated for more than 5 minutes without draining or the red status light on the control board is pulsing a 2-blink code follow the steps below.

1. Remove the collector box soft tube at location A in Figure 21 and insure the exit from the collector box is clear of any debris or obstructions.
2. Replace this tube and insure the fit to the header spout is air tight. Air will be drawn into the header if this connection is not tight.
3. Check other tube connections along the drain system. Insure that all are air tight.

NOTE: Industry research studies indicate that when condensate is routed to an active drain, household detergents, etc., buffer its acidity. If the drain is not actively used or if codes require, obtain a neutralizer kit (usually contains limestone). Proper drains and connections to the condensate tubing are required as NORDYNE cannot be held responsible for water leakage which occurs due to loose hose connections or improperly sealed drain line pipes.

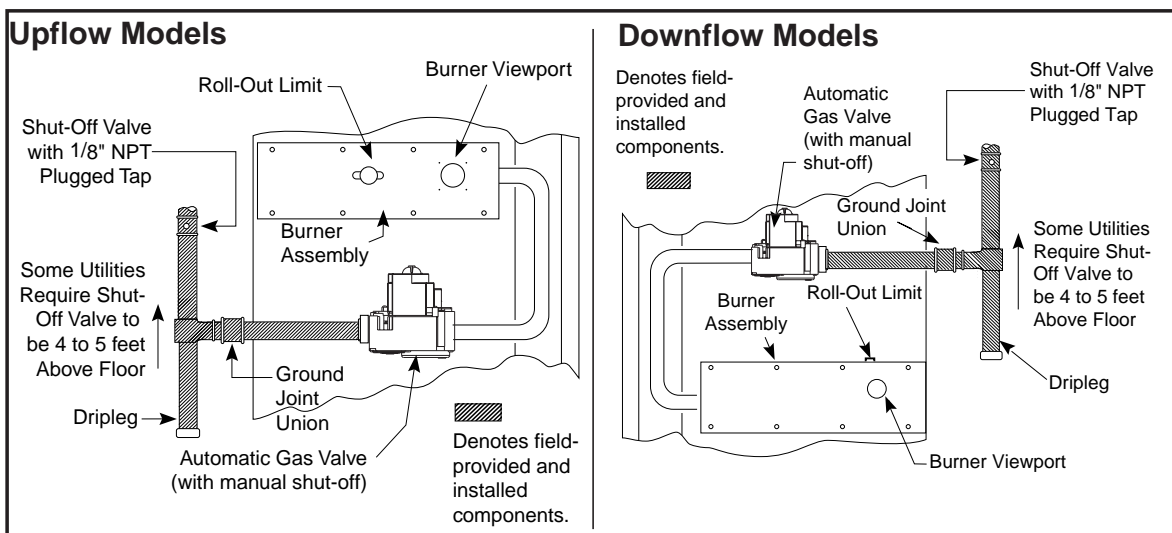

Figure 22. Typical Gas Service Connection

GAS SUPPLY AND PIPING

This furnace is equipped for either left or right side gas entry. Typical gas service hook-ups are shown in Figure 22. When making the gas connection provide clearance between the gas supply line and the entry hole in the furnace casing to avoid unwanted noise and/or damage to the furnace.

All gas piping must be installed in compliance with local codes and utility regulations. Some local regulations require the installation of a manual main shut-off valve and ground joint union external to the furnace. The shut-off valve should be readily accessible for service and/or emergency use. Consult the local utility or gas supplier for additional requirements regarding placement of the manual main gas shut-off. In the absence of local codes the gas line installation must comply with the latest edition of the National Fuel Gas Code (ANSI Z223.1) or (CAN/CGA B149) installation codes.

A 1/8" NPT plugged tap must be installed in the gas line to the unit for use when measuring the gas supply pressure. The plug should be readily accessible for service use. A drip leg should be installed in the vertical pipe run to the unit. Table 5 lists gas flow capacities for standard pipe sizes as a function of length in typical applications based on nominal pressure drop in the line.

NOTE: Gas piping must not be run in or through air ducts, chimneys, gas vents, elevator shafts, etc.

Compounds used on threaded joints of gas piping must be resistant to the actions of liquefied petroleum gases.

The main manual gas valve and main power disconnect to the furnace must be properly labeled by the installer in case emergency shut-down is required.



CAUTION:

Do not use matches, lighters, candles, or other sources of open flame to check for gas leaks.

Leak Check



WARNING:

FIRE OR EXPLOSION HAZARD
Failure to follow the safety warnings exactly could result in serious injury, death or property damage.

Never test for gas leaks with an open flame. Use a commercially available soap solution made specifically for the detection of leaks to check all connections. A fire or explosion may result causing property damage, personal injury or loss of life.

After the gas piping to the furnace is complete, all connections must be tested for gas leaks. To check for leaks use only a soap and water solution or other approved method.

IMPORTANT NOTE: When pressure testing gas supply lines at pressures greater than 1/2 psig (14 in. water column), the furnace must be disconnected from the gas supply piping system to prevent damage to the gas control valve. If the test pressure is less than or equal to 1/2 psig (14 in. water column), the furnace must be isolated from the gas supply line by closing the manual shut-off valve.



WARNING:

This furnace was equipped at the factory for use with natural gas only. A special kit, supplied by the manufacturer, is required to convert the furnace to operate on LP/propane gas. Failure to use the proper conversion kit can cause fire, explosion, property damage, carbon monoxide poisoning, personal injury, or death.

Conversion

Conversion of this furnace to use LP/propane gas must be made by qualified service personnel, using **only** approved parts.

CAPACITY OF BLACK IRON GAS PIPE (CU. FT. PER HOUR) FOR NATURAL GAS (SPECIFIC GRAVITY - 0.60)								
NOMINAL BLACK IRON PIPE DIAMETER (in.)	LENGTH OF PIPE RUN (feet)							
	10	20	30	40	50	60	70	80
1/2	130	90	75	65	55	50	45	40
3/4	280	190	150	130	115	105	95	90
1	520	350	285	245	215	195	180	170
1 1/4	1050	730	590	500	440	400	370	350
1 1/2	1600	1100	890	760	670	610	560	530

The cubic feet per hour listed in the table above must be greater than the cubic feet per hour of gas flow required by the furnace. To determine the cubic feet per hour of gas flow required by the furnace, divide the input rate of the furnace by the heating value of the gas:

$$\text{Cubic Feet Per Hour Required} = \frac{\text{Input To Furnace (Btu/hr)}}{\text{Heating Value of Gas (Btu/Cu. Ft.)}}$$

Table 6. Capacity of Black Iron Gas Pipe (cu. ft. per hour) for Natural Gas (specific gravity = .60)

For a Natural Gas Sea Level Heating Value of 800 to 899 Btu/cu.ft.					
	Elevation (feet above sea level)				
	zero to 1999	2000 to 4999	5000 to 5999	6000 to 7999	8000 to 10000
Manifold Pressure Setting (in WC)	3.5	3.5	3.5	3.5	3.0

For a Natural Gas Sea Level Heating Value of 900 to 999 Btu/cu.ft.					
	Elevation (feet above sea level)				
	zero to 1999	2000 to 4999	5000 to 5999	6000 to 7999	8000 to 10000
Manifold Pressure Setting (in WC)	3.5	3.5	3.5	3.2	2.8

For a Natural Gas Sea Level Heating Value of 1,000 to 1,100 Btu/cu.ft.					
	Elevation (feet above sea level)				
	zero to 1999	2000 to 4999	5000 to 5999	6000 to 7999	8000 to 10000
Manifold Pressure Setting (in WC)	3.5	3.5	3.0	2.8	2.5

Table 7. Manifold Pressure (in WC) for Natural Gas at Various Altitudes

	Elevation (feet above sea level)				
	0 to 1,999	2,000 to 4,999	5,000 to 5,999	6,000 to 7,999	8,000 to 10,000
Manifold Pressure in (WC) for an LP Gas Heating Value of 2,500 Btu/hr.	10.0	8.5	10.0	9.0	8.5

Table 8. Manifold Pressure (in WC) for LP/Propane Gas at Various Altitudes

Furnace Rating Plate Input (Btu/h)	Orifice Drill Size	
	Nat.	LP
40,000	45	55
60,000	45	55
80,000	45	55
100,000	45	55
120,000	45	55

Table 9. Natural and LP Gas Orifice Sizes for Elevations between zero and 4999 ft. Above Sea Level

Furnace Rating Plate Input (Btu/h)	Orifice Drill Size	
	Nat.	LP
40,000	45	56
60,000	45	56
80,000	45	56
100,000	45	56
120,000	46	56

Table 10. Natural and LP gas Orifice Sizes for Elevations between 5000 and 10,000 ft. Above Sea Level

High Altitude Application

High altitude application with this furnace can be field performed by a simple adjustment of manifold pressure, and if necessary changing the orifices. The changes required depend on the installation altitude and the heating value of the gas. The gas heating value based on sea level can be obtained from your local gas utility. The heating value of gas at high altitude is always lower than the sea level heating value. The heating values used in Tables 7 & 8 are based on sea level values.

Natural Gas High Altitude Conversion

All factory shipped furnaces are ready to operate between zero and 4999 ft. above sea level. For higher altitudes (between 5000 and 10,000 ft. above sea level), conversion can be achieved simply by adjusting the furnace manifold pressure as shown in Table 7.

LP/Propane Gas Sea Level and High Altitude Conversion

IMPORTANT NOTE: When converting a low NOx furnace from Natural gas to LP/propane gas, it is necessary to remove the NOx Baffles from the furnace.

Conversion of this furnace to utilize LP/propane gas must be made by qualified service personnel, using factory authorized or approved parts. Conversion to LP/propane gas can be accomplished by first replacing the natural gas orifices with the appropriate LP/propane orifices shown in Table 9 or 10. Note: for installations between zero and 5000 ft. above sea level, a #54 or #55

drill size orifice should be used depending upon the rated firing rate of the unit (see Table 9 or 10). However for installations above 5000 ft. above sea level, a # 55 or #56 drill size orifice should be used. After changing the orifices, use Table 8 to determine the appropriate manifold pressure for your installation.

Conversion to LP/propane, sea level, and high altitude is detailed in the installation instructions provided with the conversion kit. Approved conversion kits are listed below.

United States LP/Propane Gas Sea Level and High Altitude Conversion Kit - P/N 903616

This kit is for LP/propane conversion in the United States at altitudes between zero and 10,000 ft. above sea level. Follow the installation instructions supplied with the kit for proper installation.

Canadian LP/Propane Gas Sea Level and High Altitude Conversion Kit - P/N 903617

This kit is for LP/propane conversions in Canada at altitudes between zero and 4500 ft. above sea level. Follow the installation instructions supplied with the kit for proper installation.



CAUTION:

To avoid electric shock, personal injury, or death, turn off the power at the disconnect or the main service panel before making any electrical connections.

Furnace Input (Btuh)	Cabinet Width (in.)	Nominal Electrical Supply	Maximum Operating Voltage	Minimum Operating Voltage	Maximum Furnace Amperes	Minimum Wire Gauge	Maximum Fuse or Circuit Breaker Amps*
40,000	14.25	115-60-1	127	103	7.8	14	15
60,000	14.25	115-60-1	127	103	7.8	14	15
80,000	19.75	115-60-1	127	103	9.7	14	15
100,000	19.75	115-60-1	127	103	9.7	14	15
120,000	22.50	115-60-1	127	103	12.9	12	20

* Time-delay fuses or HACR-type circuit breakers are required.

Thermostat Wire Gauge	Recommended Thermostat Wire Length	
	2-wire (heating)	4 or 5-wire (cooling)
24	55 ft.	25 ft.
22	90 ft.	45 ft.
20	140 ft.	70 ft.
18	225 ft.	110 ft.

Table 11. Electrical Data

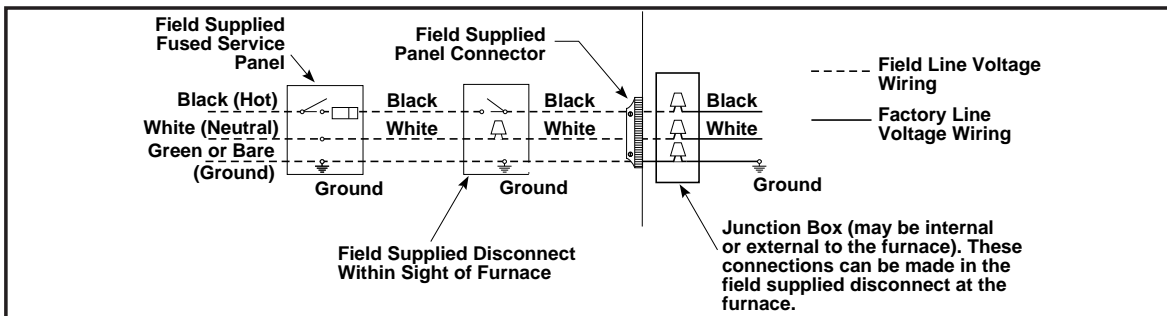

Figure 23. Line Voltage Field Wiring

ELECTRICAL WIRING

Electrical connections must be made in accordance with all applicable local codes and ordinances, and with the current revision of the National Electric Code (ANSI/NFPA 70).

For Canadian installations electrical connections and grounding must be done in accordance with the current Canadian Electrical Code (CSA C22.1 Part 1) and/or local codes. If any of the original wire as supplied with the furnace must be replaced, it must be replaced with wire having a minimum temperature rating of 105°C. Refer to the furnace nameplate and Table 11 for electrical requirements.

Line Voltage Wiring

The line voltage (115 volt) to the furnace must be supplied from a dedicated branch circuit containing the correct fuse or circuit breaker for the furnace. See Table 11. An electrical switch should be readily accessible from and within sight of the furnace. (See the Wiring Diagram label in the furnace and Figure 23.)

The furnace cabinet must have an uninterrupted, unbroken ground to minimize injury should an electrical fault condition occur. The controls used in this furnace require an earth ground to operate properly. Acceptable methods for grounding are electrical wire or conduit approved for electrical ground service. Do not use gas piping as an electrical ground.

NOTE: Proper line voltage polarity must be maintained in order for the control system to operate correctly. Verify that the incoming neutral line is connected to the white wire and the incoming “hot” line is connected to the black wire in the junction box. These furnaces will not operate unless polarity and ground are properly connected. See Figure 23.

⚠ CAUTION:

Label all wires prior to disconnection when servicing controls. Wiring errors can cause improper and dangerous operation. Verify proper operation after servicing.

Low Voltage Wiring

Install the thermostat per the manufacturer's instructions. The low voltage (24 volt) connections from the thermostat are made at the terminal strip on the control board in the furnace. See Figure 24 for the proper connections for heating only (two-wire) and heating/cooling (four-wire) applications. The recommended minimum wire gauge for thermostat wiring is shown in Table 11.

The thermostat must not be installed on an outside wall or any other location where its operation may be adversely affected. Adverse affects include radiant loading from fireplaces, sunlight, or lighting fixtures, and convective loading from warm air registers or electrical appliances.

To check the heat anticipator setting either:

1. Add the current draw of the system components; or
2. Measure the current flow on the thermostat R-W circuit after the circulating blower motor has started.

Set the heat anticipator according to the thermostat manufacturer's instructions for heat anticipator settings.

START-UP AND ADJUSTMENTS

Prior to start-up, verify that:

1. The line voltage power leads are securely connected, that the polarity of the connec-

- tions is correct, and that the furnace is properly grounded.
- The thermostat wires (R, W, Y, and G) are securely connected to the correct leads on the terminal strip of the circuit board.
 - The gas line service pressure does not exceed 10.0 in. water column (0.36 psig), and is not less than 4.5 in. water column (0.16 psig) for natural gas. For LP gas the line service pressure must not exceed 14 in. water column (0.51 psig), and must not be less than 11.0 in. W.C. (0.40 psig).
 - The roll-out and vent safety manual reset switches are closed. If necessary, press the red button to reset a switch. See Figure 28 for location. DO NOT install a jumper wire across a switch to defeat its function. If a switch reopens on start-up, DO NOT reset the switch without identifying and correcting the fault condition which caused the switch to trip.
 - The blower door is in place, closing the door switch in the line voltage circuit.
 - The gas line has been purged and all connections are leak tight.

Start-Up Procedure

- Set the thermostat to the lowest setting.
- Close the disconnect(s) to provide line voltage to the furnace.
- Follow the procedures given on the operating instructions label attached to the furnace.
- Set the thermostat above room temperature and verify the sequence of operation. (See the SEQUENCE OF OPERATION.)
- After the furnace has run for approximately five minutes, set the thermostat below room temperature and verify steps (9) through (11) of the SEQUENCE OF OPERATION.

Verifying and Adjusting Firing Rate

The firing rate must be verified for each installation to prevent over-firing the furnace.

NOTE: The firing rate must not exceed the rate shown on the furnace rating plate. At altitudes above 2000 ft. the firing rate must be adjusted as described in the high altitude section.

Use the following procedure to determine the firing rate:

- Shut off all other gas fired appliances.
- Start the furnace and allow it to run for at least three minutes.
- Measure the time (in seconds) required for the gas meter to complete one revolution.
- Convert the time per revolution to cubic feet of gas per hour using Table 12.
- Multiply the gas flow rate in cubic feet per hour by the heating value of the gas in Btu per cubic foot to obtain the firing rate in Btuh. Example:
 - Time for 1 revolution of a gas meter with a 1 cubic foot dial = 40 seconds.
 - From Table 9 read 90 cubic feet per hour of gas.
 - Heating value of the gas (obtained from gas supplier) = 1040 Btu per cubic foot.
 - Firing rate = 1040 x 90 = 93,600 Btuh.
- Adjustments to the firing rate can be made by adjusting the gas manifold pressure. See the High Altitude Application section for additional information of firing rate at elevations above 2000 ft.

The manifold pressure must be set to the appropriate value for your installation. Refer to either Table 7 for natural gas or Table 8 for LP/propane gas to verify the manifold pressure setting required for your particular installation. To adjust the manifold pressure, remove the regulator cap and turn the adjusting screw clockwise to increase pressure or counterclockwise to reduce pressure. Replace the regulator cap after adjustments are complete.

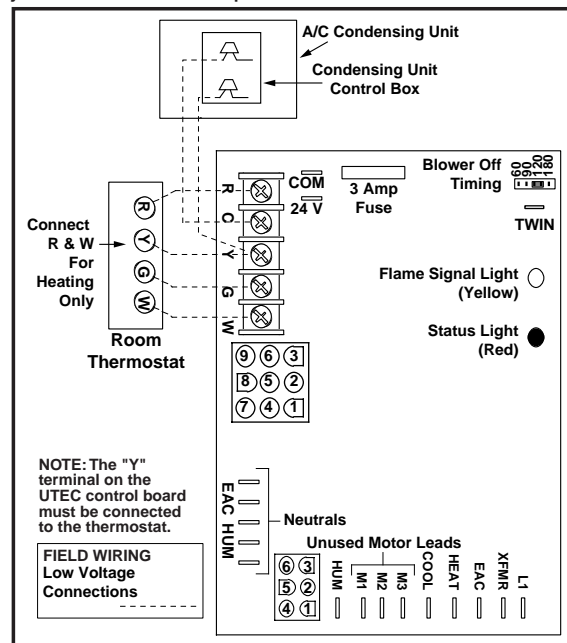

Figure 24. Low Voltage Field, Four-wire Heating/Cooling Applications

! CAUTION:

Do not re-drill the burner orifices. If the orifice size must be changed, use only new orifices.

Verifying and Adjusting Temperature Rise

Verify that the temperature rise through the furnace is within the range specified on the furnace rating plate. Temperature rises outside the specified range could result in premature heat exchanger failure.

Place thermometers in the return and supply air stream as close to the furnace as possible. The thermometer on the supply air side must be shielded from direct radiation from the heat exchanger to avoid false readings. Adjust all registers and duct dampers to the desired position and run the furnace for fifteen minutes before taking any temperature readings. The temperature rise is the difference between the supply and return air temperatures.

For typical duct systems, the temperature rise will fall within the range specified on the rating plate with the blower speed at the factory recommended setting. If the temperature rise measured is outside the range specified, it may be necessary to change the blower speed. Lower blower speeds will increase the temperature

rise and higher blower speeds will decrease the temperature rise.

The furnace is equipped with a multispeed motor. Heating and cooling speed selection is made by moving the leads on the integrated control board located in the furnace. The wiring diagram on the furnace and Figures 25, 26 and 27 show the speed taps for adjusting motor speed.

If it is desired that the blower operate at the same speed for heating and cooling, tape off the terminal of the unused blower wire. Install the jumper wire, found in the plastic instruction bag, found across the HEAT and COOL taps on the control board. Reconnect the desired blower tap to the piggyback quick connect.

The blower control is designed to start the circulating air blower 30 seconds after the gas valve is opened. The blower control is factory wired to turn the blower motor off 120 seconds after the gas valve is closed. This timing can be changed using the BLOWER OFF timing switch opposite the terminal block on the control board. (See Figure 25.)

Verifying Burner Operation

To verify operation of the burners, make sure that the blower compartment door is in place and that there is power to the furnace. Set the thermostat above room temperature and observe the ignition sequence. The flame can be observed through the small clear window on the

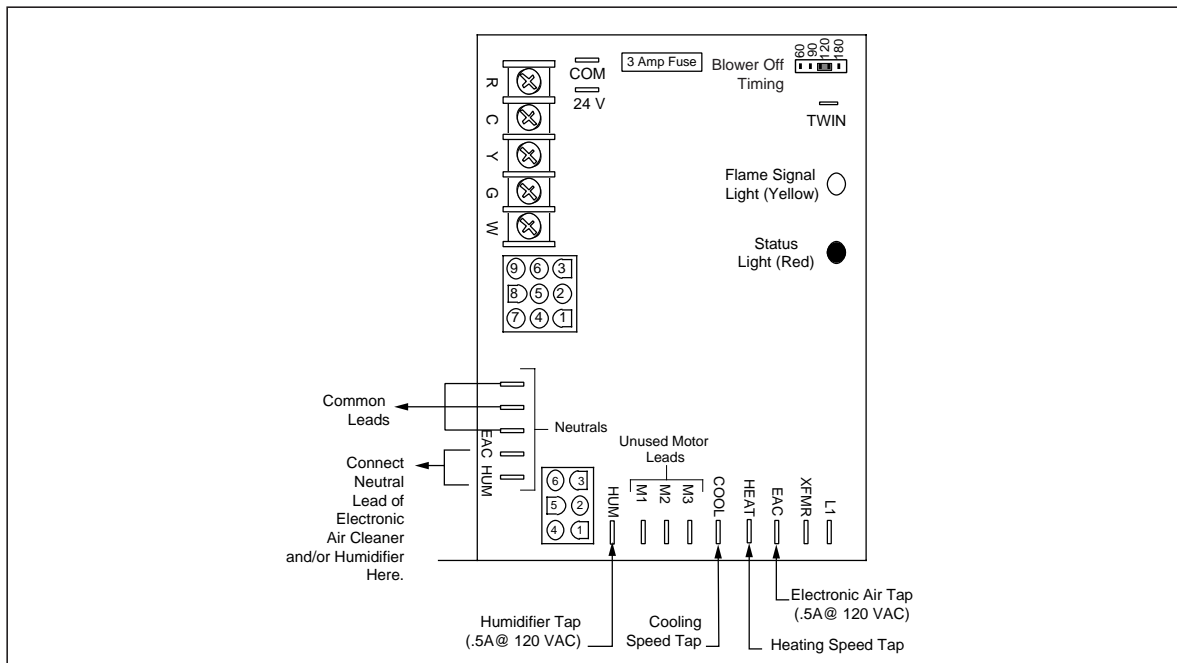

Figure 25. Blower Speed Tap Location

GAS FLOW RATE (CUBIC FEET PER HOUR)							
TIME FOR ONE REVOLUTION (SECONDS)	CUBIC FEET PER REVOLUTION OF METER			TIME FOR ONE REVOLUTION (SECONDS)	CUBIC FEET PER REVOLUTION OF METER		
	1	5	10		1	5	10
24	150	750	1500	80	45	225	450
26	138	692	1385	82	44	220	439
28	129	643	1286	84	43	214	429
30	120	600	1200	86	42	209	419
32	113	563	1125	88	41	205	409
34	106	529	1059	90	40	200	400
36	100	500	1000	92	39	196	391
38	95	474	947	94	38	191	383
40	90	450	900	96	38	188	375
42	86	429	857	98	37	184	367
44	82	409	818	100	36	180	360
46	78	391	783	102	35	176	353
48	75	375	750	104	35	173	346
50	72	360	720	106	34	170	340
52	69	346	692	108	33	167	333
54	67	333	667	110	33	164	327
56	64	321	643	112	32	161	321
58	62	310	621	114	32	158	316
60	60	300	600	116	31	155	310
62	58	290	581	118	31	153	305
64	56	281	563	120	30	150	300

Table 12. Gas Flow Rate

burner box. The burner flame should carry over between all burners. The flames should be blue, without yellow tips. Flames should extend from each burner without lifting, curling, or floating. After verifying ignition, set the thermostat below room temperature and verify that the burner flame extinguishes completely.

Verifying Operation of the Supply Air Limit Switch

To verify operation of the supply air limit switch, make sure that the blower door is in place and that there is power to the furnace. Completely block the return airflow to the furnace by installing a close-off plate in place of or upstream of the filter(s). Set the thermostat above room temperature and verify that the Sequence of Operation is as described in these instructions. The supply air limit switch should function to turn off the gas valve within approximately five minutes. The circulating air and combustion blowers should continue to run when the supply air limit switch opens. Remove the close-off plate immediately after the supply air limit switch opens. If the furnace operates for more than five minutes with no return air, set the thermostat below room temperature, shut off the power to the furnace, and replace the supply air limit switch.

DESCRIPTION OF COMPONENTS

Figure 28 shows the location of each of the functional components described below. If

any component of the furnace must be replaced, use only factory authorized replacement parts. See the Replacement Parts List for each component.

Flame Sensor – The flame sensor acts to prove that flame has carried over from the igniter to the opposite end burner. If no flame is sensed, the furnace will be shut down automatically.

Gas Valve – The gas valve controls the flow of gas to the burners. When the gas valve is energized it automatically opens and regulates the gas pressure in the manifold.

Pressure Switch – The pressure switch verifies that the inducer is drawing the combustion gases through the heat exchanger. It also senses a blocked condensate drain condition.

Vent Pressure Switch – The vent pressure switch reacts to blockage in the vent or combustion air piping.

Supply Air Limit Switch – The supply air limit switch prevents the air temperature leaving the furnace from exceeding the maximum outlet air temperature.

Vent Safety Switch – The vent safety switch shuts the furnace down if the outlet flue gas temperature increases above 160°F. This switch protects the plastic flue system and the inducer from over-temperature conditions.

Flame Roll-Out Switch – This switch provides flame roll-out protection to the furnace and combustion air inlet pipe.

MAINTENANCE

It is recommended that the furnace be checked yearly. At a minimum, this check should include the following items.

**WARNING:**

To avoid electric shock, personal injury, or death, disconnect the electric power before performing any maintenance.

**WARNING:**

Holes in the vent pipe or heat exchanger can cause products of combustion to enter the home. Replace the vent pipe or heat exchanger if leaks are found. Failure to prevent products of combustion from being circulated into the living space can create potentially hazardous conditions including carbon monoxide poisoning that could result in personal injury or death.

Combustion Air and Vent System

Check the combustion air and vent pipe to ensure that it is not damaged, corroded or blocked by debris. Any damaged section of vent pipe must be replaced, and any obstruction or blockage must be removed prior to operating the furnace.

Air Filter(s)

**WARNING:**

Never operate the furnace without a filter in place. Dust and lint in the return air can build up on internal components, resulting in loss of efficiency, equipment damage, and possible fire.

AIR FILTER(S) ARE NOT SUPPLIED WITH THE FURNACE AS SHIPPED FROM THE FACTORY. FILTERS FOR SIDE RETURN AND BOTTOM RETURN APPLICATIONS ARE AVAILABLE FROM YOUR LOCAL DISTRIBUTORS.

The installer should provide a filter rack for a high velocity type filter in the return air duct adjacent to the furnace. Filters should be changed or cleaned monthly during the heating season. New or newly renovated homes may require more frequent changing until the construction dust has been removed.

Lubrication

The bearings in the circulating air blower motors are pre-lubricated and sealed at the factory. No further oiling of the bearings is required for the life of the motor.

Condensate Drain Assembly

Be sure the condensate lines are free and open (i.e. avoid kinking hoses). Also make sure all hose clamps are tight to avoid drawing air into the system.

Blower Compartment

The blower compartment should be cleaned monthly during the heating and cooling seasons to remove any dirt and lint that may have accumulated in the compartment or on the blower and motor. Dirt and lint can create excessive loads on the motor resulting in higher than normal operating temperatures and shortened service life.

Heat Exchanger and Burner Maintenance

The furnace should operate for many years without excessive soot buildup in the flue passageways, however, the flue passageways, the vent system, and the burners should be inspected and cleaned (if required) by a qualified serviceman annually to ensure continued safe operation. Particular attention must be given to identify deterioration from corrosion or other sources.

SYSTEM OPERATION INFORMATION

Proper maintenance is most important to achieve the best performance from a furnace. Follow these instructions for years of safe, trouble free operation.

- **Do not place combustible materials on or against the furnace cabinet or the vent pipe.**
- **Do not store gasoline or any other flammable vapors and liquids in the vicinity of the furnace.**

For Upflow and Downflow Residential Furnaces

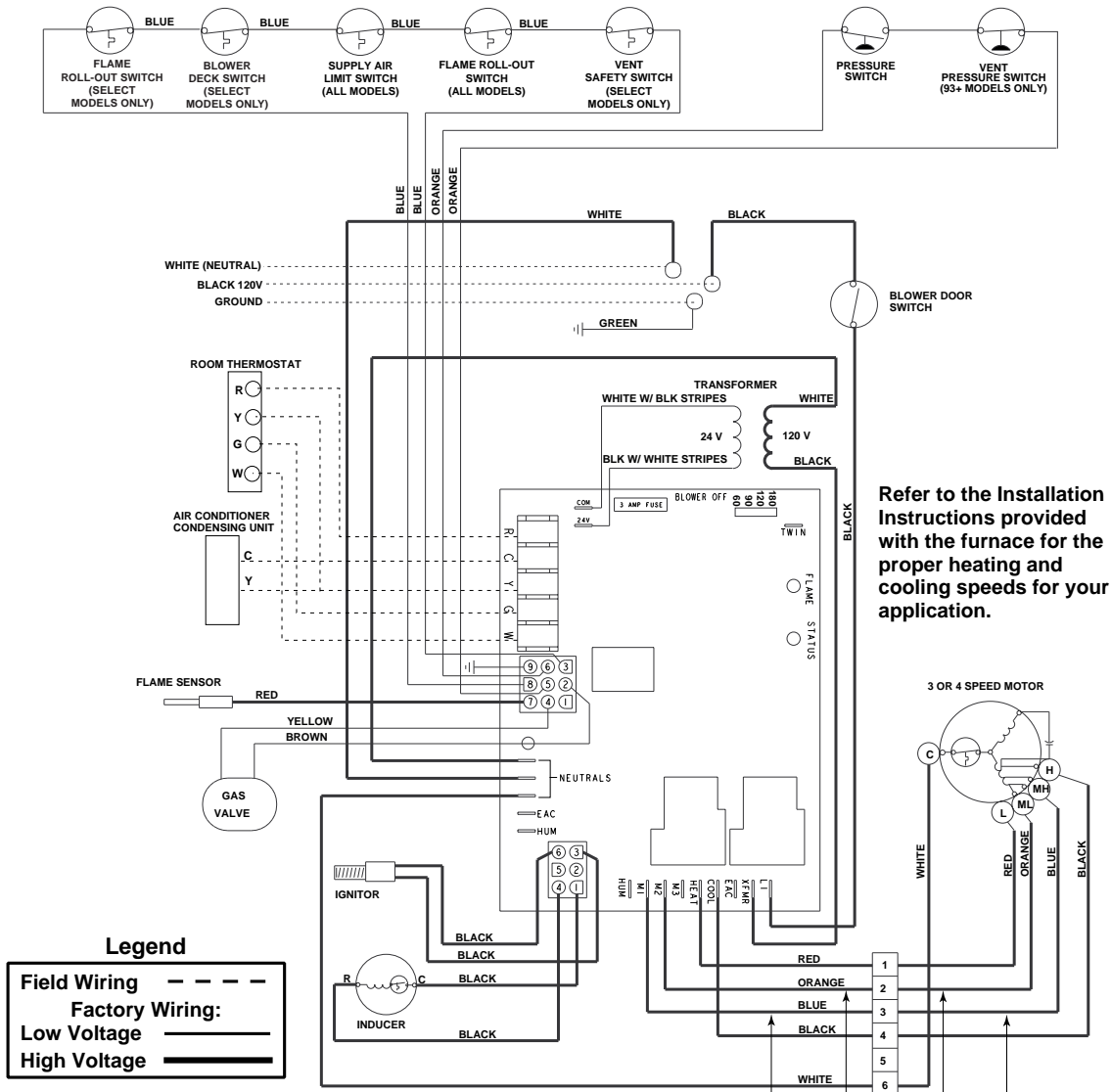

Refer to the Installation Instructions provided with the furnace for the proper heating and cooling speeds for your application.

These wires are not present on all models

Legend
 Field Wiring - - - - -
 Factory Wiring: _____
 Low Voltage _____
 High Voltage _____

FAULT CONDITION	STATUS RED LIGHT
Power On	ON
Limit Circuit Open or External Load On "W"	1 FLASH
Pressure Switch is Open with Inducer On	2 FLASHES
Pressure Switch is Closed with Inducer Off	3 FLASHES
Ignition Failure (Check Ground)	4 FLASHES
115 VAC & Neutral Reversed or no Ground	5 FLASHES
False Flame or Gas Valve Relay Shorted	Continuous
Power Off	OFF

FAULT CONDITION	FLAME YELLOW LIGHT
Low Flame Sensor Signal	Continuous Flash
Flame Present	ON

If any of the original wire as supplied with the furnace must be replaced, it must be replaced with wiring material having a temperature rating of at least 105 C.

WD# 710128B

Figure 26. Upflow and Downflow Wiring Diagram

Upflow Furnace Models

- 1 Igniter (Not Shown)
- 2 Flame Sensor (Not Shown)
- 3 Gas Valve
- 4 Flame Roll-out Switch(s)
- 5 Pressure Switch
- 6 Vent Pressure Switch (Not Shown)
- 7 Control Board
- 8 Blower Door Switch
- 9 Vent Safety Switch
- 10 Low Voltage Transformer
- 11 Supply Air Limit Switch
- 12 Circulating Air Blower Assembly-
- 13 Induced Draft Blower
- 14 Condensate Drain Tube
- 15 In-Line Drain Assembly
- 16 Burner View Port
- 17 Front Header Box
- 18 Combustion Air Intake
- 19 Exhaust Vent

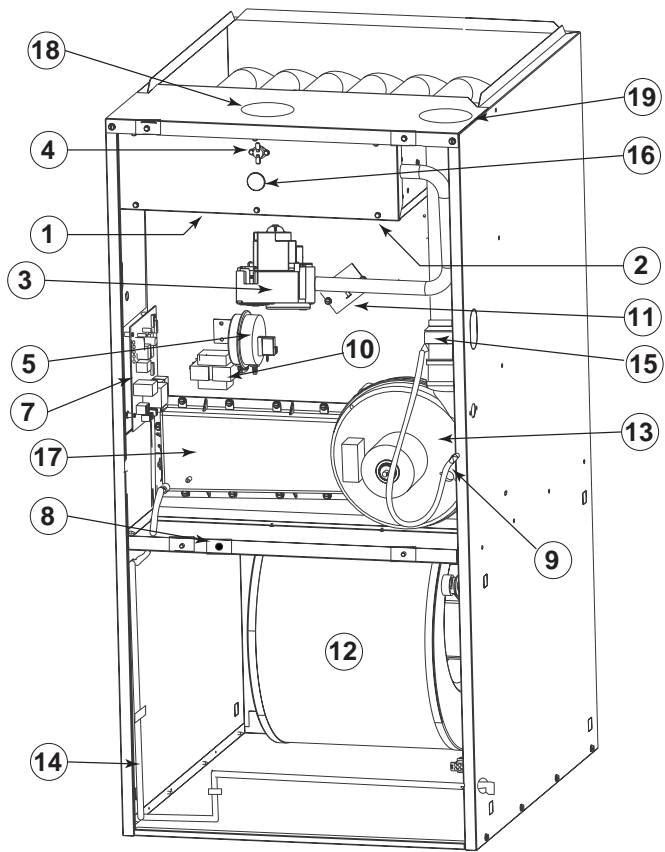

Downflow Furnace Models

- 1 Igniter (Not Shown)
- 2 Flame Sensor (Not Shown)
- 3 Gas Valve
- 4 Flame Roll-out Switch(s)
- 5 Pressure Switch
- 7 Control Board
- 8 Blower Door Switch
- 9 Vent Safety Switch
- 10 Low Voltage Transformer
- 11 Supply Air Limit Switch
- 12 Circulating Air Blower Assembly-
- 13 Induced Draft Blower
- 14 Condensate Drain Tube
- 15 In-Line Drain Assembly
- 16 Burner View Port
- 17 Front Header Box
- 18 Combustion Air Intake
- 19 Exhaust Vent

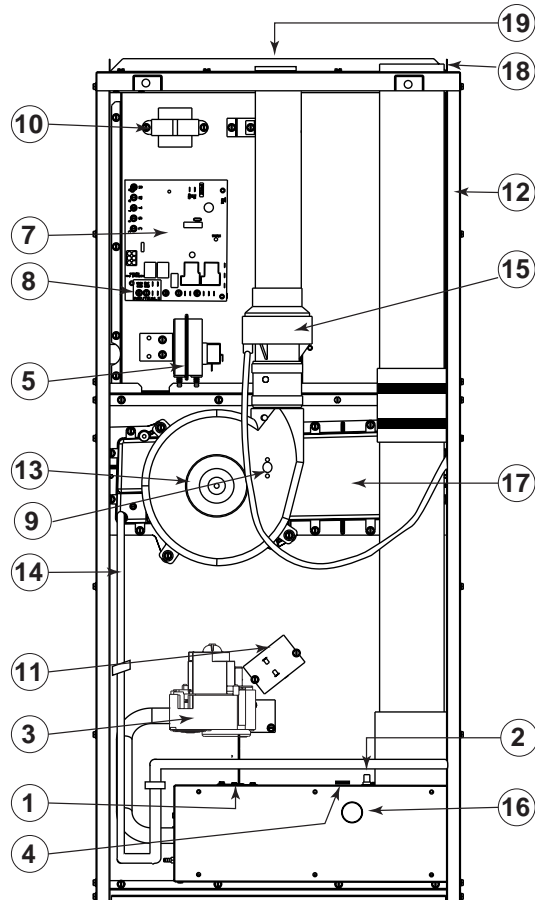

Figure 27. Location of Major Components

- **Change or replace the air filters monthly during any period when the circulating blower is operating regularly.**
- **Always replace the doors on the furnace after servicing. Do not operate the furnace without all doors and covers in place.**
- **Avoid operating the furnace when windows and doors are open.**
- **Be sure that the thermostat is properly installed and is not being affected by drafts or heat from lamps or other appliances.**

Sequence of Operation

Operating sequences for the heating, cooling, and fan modes are described below. Refer to the wiring diagrams (Figures 26) and the voltage field wiring diagram (Figure 24).

Heating Mode:

1. On a call for heat the thermostat closes, applying 24 VAC to the W terminal on the control board.
2. The control board checks for continuity on the 24 VAC limit control circuit (over-temperature limit switch, flame rollout switches and blocked vent switch in series). If an open limit is detected the control board will energize the inducer and the conditioned air blower. All other system functions will be inoperable until the limit circuit closes. While the limit is open, the red LED will pulse at a rate of 1 blink per unit time.
3. The furnace control checks for continuity across the pressure switch (24 VAC). If the pressure switch is closed the heat mode sequence will not continue. If it remains closed for 10 seconds the red LED will blink 3 times repetitively until the fault condition clears.
4. The inducer is energized.
5. The pressure switch will close. If the pressure switch does not close after 10 seconds the fault LED will blink 2 times repetitively and the inducer will continue to run until the switch is closed.
6. The inducer will pre-purge for 30 seconds and then the igniter will start its warm-up as follows:
Initial Power up: After 30 seconds of igniter warm-up the gas valve (24 VAC) will then open. The igniter circuit will stay energized for 3 seconds after the gas valve opens.
After Initial Power up: The control has a programmed adaptive ignition feature which varies the warm-up period as follows: If ignition is successful the warm-up is reduced by 3-seconds on each subsequent call for heat until ignition failure occurs. Upon ignition failure, the warm-up is increased by 3-seconds on the next try. If successful, the timing remains fixed at this level. In general, whenever ignition failure occurs the warm-up interval is increased by 3-seconds on the next try. And if successful, it remains there. Minimum and maximum warm-up time limits are set at 6 and 54-seconds, respectively.
7. The furnace control must prove flame via the flame the flame sensor 5 seconds after the gas valve opens. If flame is sensed, all burners are on and the igniter cools off. If no flame is sensed, the gas valve closes immediately and the inducer continues to run. A second trial for ignition (step 6) begins if no flame is sensed. On the fifth try for ignition, the furnace control is locked out and the red LED will blink 4 times repetitively. The thermostat must be opened for at least ten seconds to reset the furnace control after a lock out. Otherwise, the furnace will attempt another ignition sequence in 1 hour.
8. The furnace control energizes the circulating air blower on the heating speed 30 seconds after the gas valve circuit is energized .
9. When the thermostat has been satisfied, gas valve is de-energized.
10. The inducer is de-energized after a 30 second postpurge.
11. The furnace control keeps the circulating air blower energized for 120 seconds (factory set) or 60, 90, or 180 seconds (field adjustable). (See Figure 25.)
12. Abnormal conditions: If a limit opens during operation, the inducer and circulating air blower continue to operate. The gas valve is de-energized immediately. The blowers continue to operate until the limit closes. When the limit closes the inducer blower is de-energized immediately. The circulating air blower continues to operate for the specified delay (factory set at 120 seconds).

Cooling Mode:

1. On a call for cooling the thermostat closes, applying 24 VAC to the G and Y terminals on the furnace control. This closes the compressor contactor.
2. The furnace control energizes the circulating blower (115 VAC) on the cooling speed.
3. When the thermostat is satisfied, the G and Y terminals on the control board are de-energized opening the compressor contactor.
4. The circulating air blower is de-energized after a 90 second delay.

Fan Mode:

1. On a call for fan operation, the thermostat applies 24 VAC to the G terminal on the furnace control board.
2. The circulating air blower is energized immediately on the heating speed.
3. If the furnace is operated in the continuous ON position at the thermostat and is then switched to AUTO, the circulating blower will operate for a specified delay (factory set at 120 seconds).

Furnace Fails to Operate

If the furnace does not operate check the following:

1. Is the thermostat operating properly?
2. Are the blower compartment door(s) in place?
3. Is the furnace disconnect closed?

4. Has the circuit breaker tripped or the control board fuse burned open?
5. Is the gas turned on?
6. Are any manual reset switches open?
7. Is the filter dirty or plugged?
8. Is the flame sensor coated? (Remove and clean with emery cloth.)

If the furnace locks out after 5 attempts for ignition, it will try again every hour if a call for heat remains. If the inducer and circulating air blowers are operating, and items 1 through 8 have been checked, press the red reset button on the vent safety switch. (See Figure 27.) If the furnace operates after depressing the reset button, contact a qualified serviceman to identify and repair the problem.

If the furnace continues to not operate, depress the red reset buttons on the flame rollout switches. (See Figure 27.) If the furnace operates after depressing the reset buttons, contact a qualified servicemen to identify and repair the problem.

Twinning of Two Furnaces

The control board on these furnaces is capable of being twinned to another furnace of the same series, provided the circuit boards are both UTEC type. If using UTEC control boards, leave the fuses installed on each board. The thermostat wires and the 1/4 inch quick-connect terminals marked "TWIN" on the furnace controls must be connected together for twinning. (See Figure 28.)

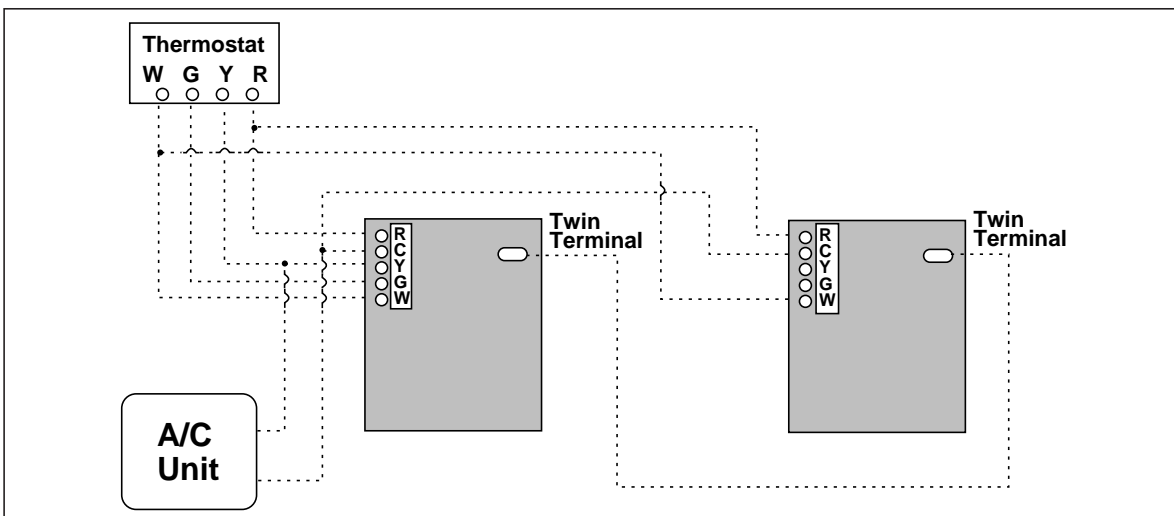

Figure 28. Twinning

INSTALLATION/PERFORMANCE CHECK LIST

LOCATION _____ CITY _____ STATE _____

INSTALLER _____ CITY _____ STATE _____

UNIT MODEL # _____ UNIT SERIAL # _____

Minimum Clearances per Table 3? _____ Supply Air Temperature: _____ (° F)

Electrical Connections tight? _____ Return Air Temperature: _____ (° F)

Line Voltage Polarity correct? _____ Temperature Rise: _____ (° F)

Supply Voltage: _____ Volts Are Flue Connections tight? _____

Blower Motor HP: _____ Is there Proper Draft? _____

FUEL TYPE: Is Vent free from restrictions? _____

Natural Gas _____ LP/Propane _____ Is the Filter(s) secured in place? _____

Gas Piping Connections leak-tested? _____ Is the Filter(s) clean? _____

Gas Line Pressure: _____ Has the Thermostat been calibrated? _____
(in. water column, with furnace operating)

Manifold Pressure: _____ Is the Thermostat level? _____
(in. water column, with furnace operating)

Is there adequate fresh air supply for combustion and ventilation? _____

Furnace Input: _____ (Btuh) Has the Heat Anticipator Setting correct? _____

Has the Owner's Information been reviewed with the home-owner? _____

Has the Literature Package been left near the furnace? _____



708184C