

USER'S MANUAL/INSTALLATION INSTRUCTIONS

P4 Series

Single Package Convertible Air Conditioner

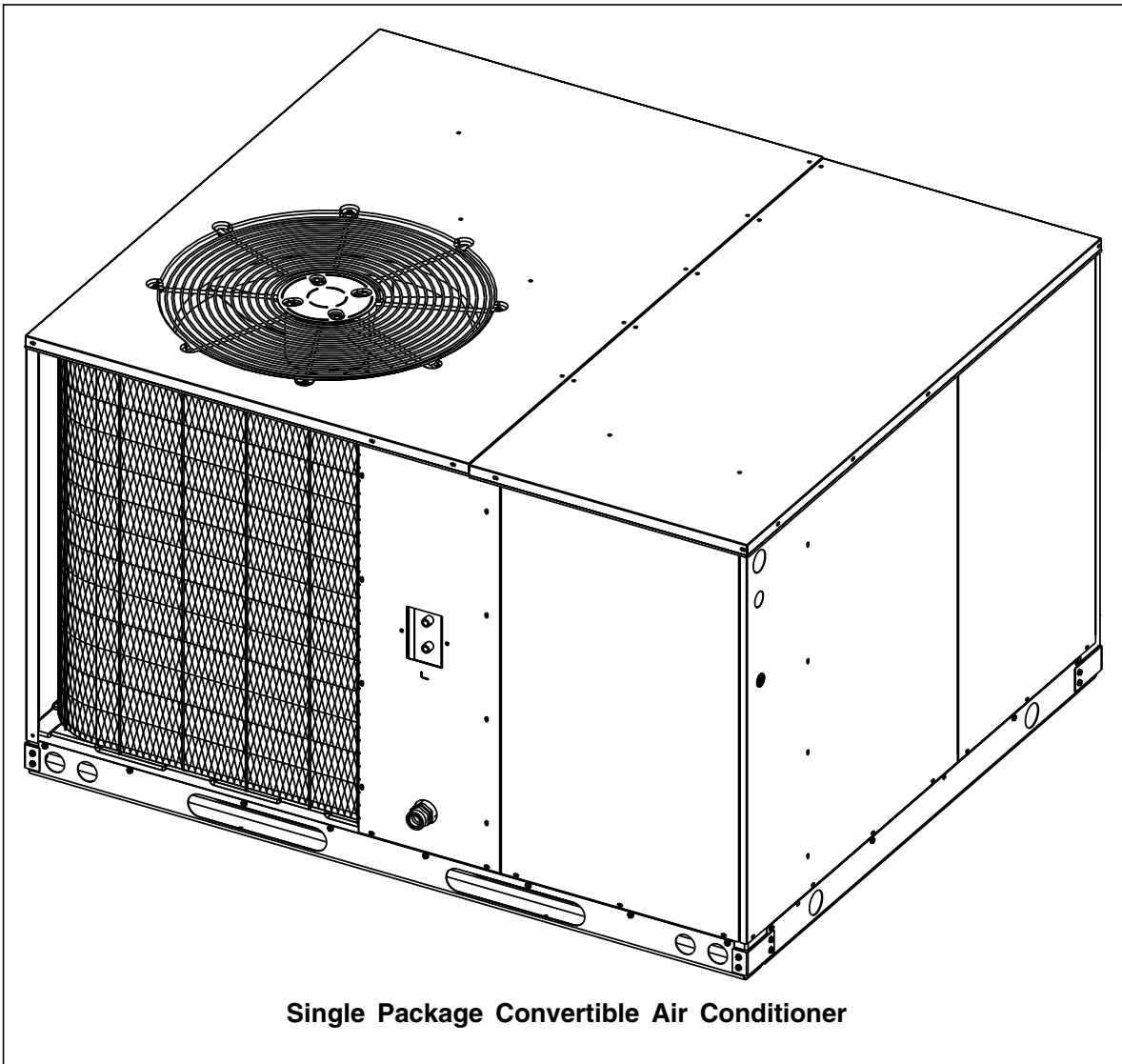

IMPORTANT

These instructions are primarily intended to assist qualified individuals experienced in the proper installation of heating and/or air conditioning appliances. Some local codes require licensed installation/service personnel for this type equipment. All installations must be in accordance with these instructions and with all applicable national and local codes and standards.

Read these instructions thoroughly before starting the installation. Follow all precautions and warnings contained within these instructions and on the unit.

OWNER INFORMATION

OPERATING INSTRUCTIONS

To Turn On Air Conditioner

If you have a heating/cooling thermostat:

1. Set the system switch to "Cool".
2. Set the thermostat at the temperature level you desire.
3. Turn the power on. Your air conditioner should start as soon as room temperature rises above the setting on the thermostat.

If you have one thermostat for heating and another for cooling, they must be interlocked to prevent simultaneous operation: (See Figure 1)

1. Turn the heating thermostat to its lowest possible setting.
2. If the cooling thermostat has an "On/Off" switch, turn it "On."
3. Set the cooling thermostat to the desired temperature.
4. Turn the power on. Your air conditioner should start when room temperature exceeds the thermostat setting.

To Shut Off Air Conditioner

If you have a heating/cooling thermostat:

1. Turn the system switch to "Heat" or "Off".
2. Turn the thermostat to the desired heating temperature setting.
3. If you are turning your air conditioner off for the winter or an extended period, shut off the power to the air conditioner.

If you have one thermostat for heating and another for cooling, they must be interlocked to prevent simultaneous operation:

1. Turn your cooling thermostat "Off" or to its highest setting.
2. Turn the heating thermostat to the desired temperature.
3. If you are turning your air conditioner off for the winter or an extended period, shut off the power to the air conditioner.

BEFORE YOU CALL A SERVICEMAN

Let your serviceman check your system at the start of each air conditioning season. He will make sure it's working right, clean or change filters and make any needed adjustments.

Otherwise, follow these simple rules:

1. Never run your system without filter. If you do, the cooling coils will get dirty and may become clogged.
2. Set your thermostat at the comfort level you wish – and then leave it alone. Let it control the operation of the air conditioning system. If you get chilly, turn it up a degree at a time until comfort is restored.
3. It takes longer for an air conditioner to cool your dwelling than it does for your furnace to heat it. So... don't turn the unit on and expect a dramatic drop in temperature, at least not right away. If your home is hot and humid, the temperature will drop slowly.
4. Check your filters every ten days in summer to see if they are dirty. To keep them clean, use a mild solution of detergent and water on washable types. Replace non washable filters.
5. Keep your condenser coil clean. You can hose it down when it gets dirty.

If your air conditioner isn't working:

1. Make sure the fuses are not blown or that your circuit breakers are on.
2. See that your thermostat is set at the desired temperature and that your system's switch is on "Cool".
3. For free air flow, make sure your return register is not covered and that the filter is clean.
4. Check the condenser coil and make sure it is clean and not clogged with grass or leaves.

If your air conditioner still isn't working, call your nearest distributor.

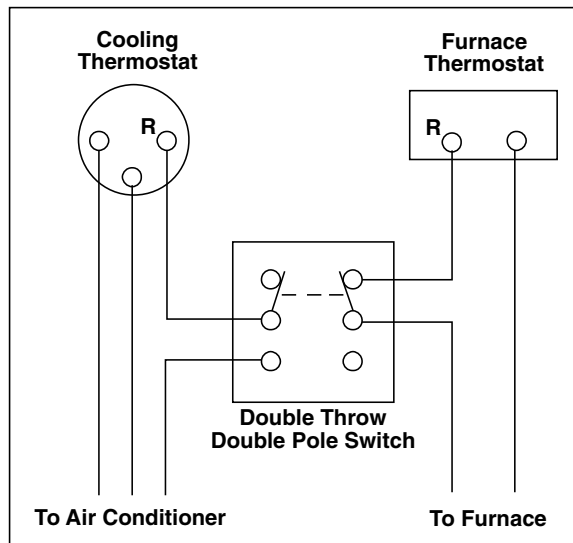

Figure 1. Thermostat Interlock System

SPECIFICATIONS

Packaged Air Conditioners are designed for outdoor rooftop or ground level slab installations. The units are shipped ready for horizontal duct connections and are easily converted for downflow applications.

All models are shipped from the factory with the following:

1. Zero clearance to combustibles.
2. Multi-speed direct-drive blower.
3. Compressor Anti-short-cycle timer (single phase models only).
4. Blower Speed Relay.
5. Horizontal or Downflow duct connections.

The unit dimensions are shown in **Figure 2**.

Optional field-installed electric heater kits are available in 5 kw through 20 kw heating capacities. A separate installation instruction document for the electric heaters and their application accompanies this one. A single stage cooling 24VAC thermostat should be used with these units. If electric heat will be installed, a single-stage cooling, single stage heating thermostat will be required.

SAFETY CONSIDERATIONS

It is the responsibility of the installer to ensure that the installation is made in accordance with all applicable local and national codes.

WARNING:

Improper installation, service, adjustment, or maintenance may cause explosion, fire, electrical shock or other hazardous conditions which may result in personal injury or property damage. Unless otherwise noted in these instructions, only factory authorized kits or accessories may be used with this product. Non-compliance may void the unit's warranty.

Labels, Tags — When working with this equipment, follow all precautions in the literature, on tags, and on labels provided with the unit and/or approved field installed kits. The type of

hazard and severity are described on each label or tag.

Pressures Within The System — This equipment contains liquid and gaseous refrigerant under high pressure. Installation or servicing should only be performed by qualified trained personnel thoroughly familiar with this type equipment.

INSTALLATION REQUIREMENTS

Equipment Check — Before beginning the installation, verify that the unit model is correct for the job. The unit model number is printed on the data label. All units have been securely packaged at the point of shipment. After unpacking the unit, carefully inspect it for apparent and concealed damage. Claims for damage should be filed with the carrier by the consignee.

Requirements and Codes — The installer must comply with all local codes and regulations which govern this type equipment. Local codes and regulations take precedence over any recommendations contained in these instructions. All electrical wiring must be made in accordance with local codes and regulations and with the National Electric Code (ANSI/NFPA 70) or in Canada the Canadian Electric Code Part 1 CSA C.22.1. Air Ducts must be installed in accordance with the standards of the National Fire Protection Association “Standards for Installation of Air Conditioning and Ventilation Systems” (NFPA 90A), “Standard for Installation of Residence Type Warm Air Heating and Air Conditioning Systems” (NFPA 90B), these instructions and all applicable local codes.

NFPA publications are available by writing:

National Fire Protection Association
Batterymarch Park
Quincy, Maine 02269

Unit Location — This air conditioner is designed only for outdoor installations. Choosing the location of the unit should be based on minimizing the length of the supply and return ducts. Consideration should also be given to availability of electric power, service access, noise, and shade. Sufficient clearance for unobstructed airflow through the outdoor coil must be maintained in order to achieve rated performance. See **Figure 3** for minimum clearances to obstructions.

Model No.	Unit Weight	Center of Gravity		Height (in inches)	
		A	B	C	
				with base rails	without base rails
3 Ton 10 SEER	420	28.0	26.0	35.0	31.3
4 Ton 10 SEER	510	28.0	26.0	35.0	31.3
5 Ton 10 SEER	540	29.5	26.5	39.0	35.3
3 Ton 12 SEER	455	28.0	25.5	35.0	31.3
4 Ton 12 SEER	565	29.5	26.0	39.0	35.3
5 Ton 12 SEER	575	29.5	26.0	39.0	35.3

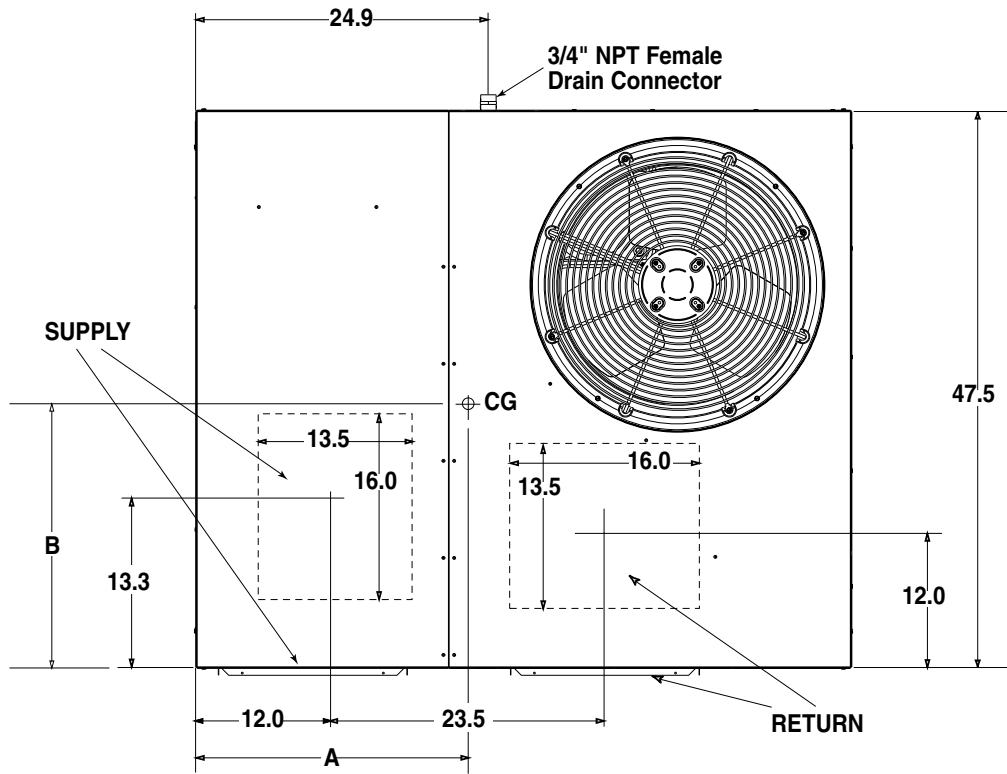

Top View

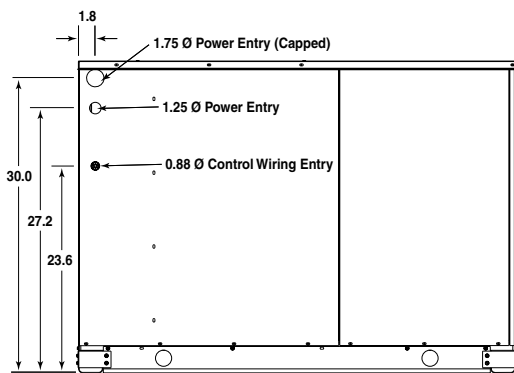

Side View

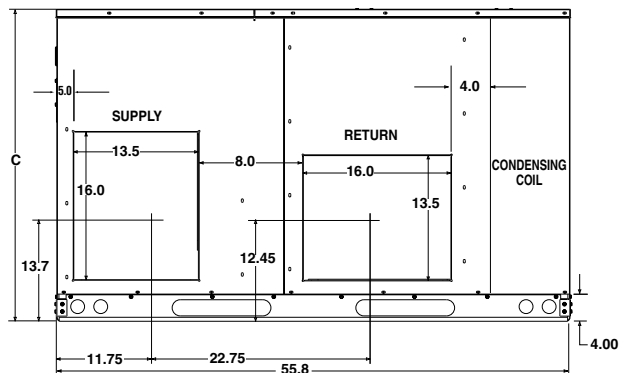

Back View

Figure 2. Dimensions

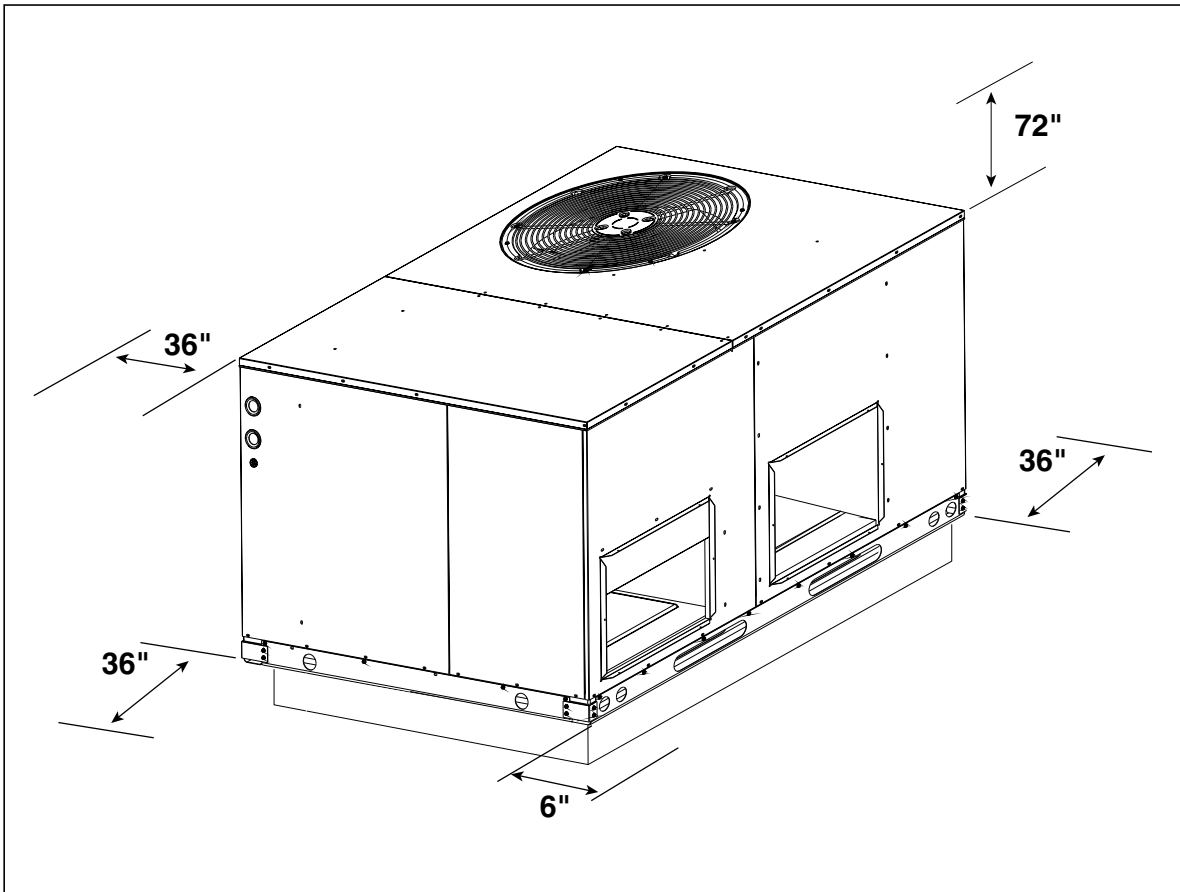

Figure 3. Minimum Clearances

Air Filter — A suitable air filter must be installed in the return air system. Air filter pressure drop must not exceed 0.08 inches w.c.

Condensate Drain — Condensate is removed from the unit through the 3/4" female pipe fitting located on the front side of the unit. (See Figure

4.) Install a 2 inch condensate trap in the drain line of the same size and prime with water. When connecting rigid drain line, hold the female fitting with a wrench to prevent twisting. **Do not over-tighten!** Refer to local codes and restrictions for proper condensate disposal requirements.

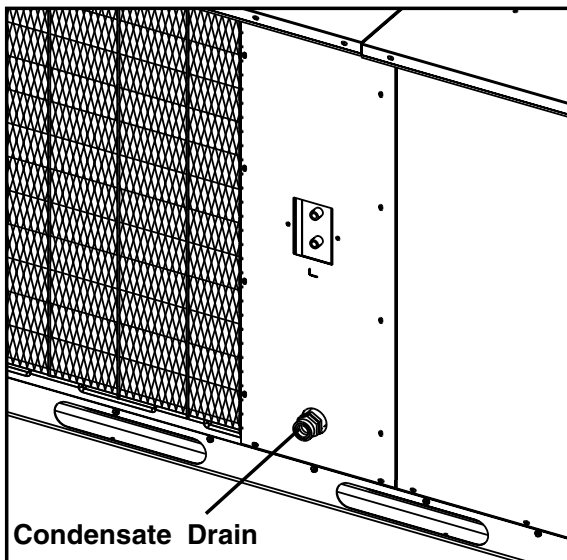

Figure 4. Condensate Drain

UNIT INSTALLATION

Ground Level — When installing the unit at ground level, provide a concrete mounting pad separate from the building foundation. The pad must be level to insure proper condensate disposal and strong enough to support the unit's weight. Refer to **Figure 2**. Make sure the slab is a minimum of 2" above the grade and in an area that drains well. (Figure 5)

WARNING:

To avoid the risk of property damage or personal injury; it is the rigger's responsibility to insure that whatever means are used to hoist the unit are safe and adequate.



CAUTION:

All panels must be securely in place when rigging and hoisting.

Rigging and Hoisting — The unit should be lifted using slings and spreader bars. The spreader bars are necessary to prevent damaging the top of the unit's cabinet. Make sure that the lifting equipment is adequate for the load. Refer to **Figure 2** for unit weights. Keep the unit in an upright position at all times. **For rooftop installations, remove and discard the two supports attached beneath the unit.**

The rigging must be located outside the unit's center of gravity. Refer to **Figure 2** for center of gravity location.

Rooftop — For rooftop installations use the appropriate accessory roof curb and follow all instructions included with it. Make sure the two supports beneath the unit have been removed. Locate the unit according to local building codes and ordinances. The curb must be level to insure proper condensate drainage. **(See Figure 6)**

The roof must be capable of handling the weight of the unit. **(See Figure 2)** for unit weights. Reinforce the roof if required.

AIR DUCTS

This unit is designed only for use with a supply and return duct. Air ducts should be installed in accordance with the standards of the National Fire Protection Association "Standard for Installation of Air Conditioning Systems" (NFPA 90A), "Standard for Installation of Residence Type Warm Air Heating and Air Conditioning Systems" (NFPA 90B), and all applicable local codes.

Design the duct work according to methods described by the National Warm Air Heating and Air Conditioning Association (ACCA). The ducts must be properly sized not to exceed .2" w.c. pressure drop at 400 scfm per nominal ton of cooling capacity.

Duct work should be attached directly to the unit flanges for horizontal applications. On roof curb installations the ducts must be attached to the curb hangers, not the unit.

Unconditioned Spaces — All duct work passing through unconditioned space must be properly insulated to minimize duct losses and prevent condensation. Use insulation with an outer vapor barrier. Refer to local codes for insulation material requirements.

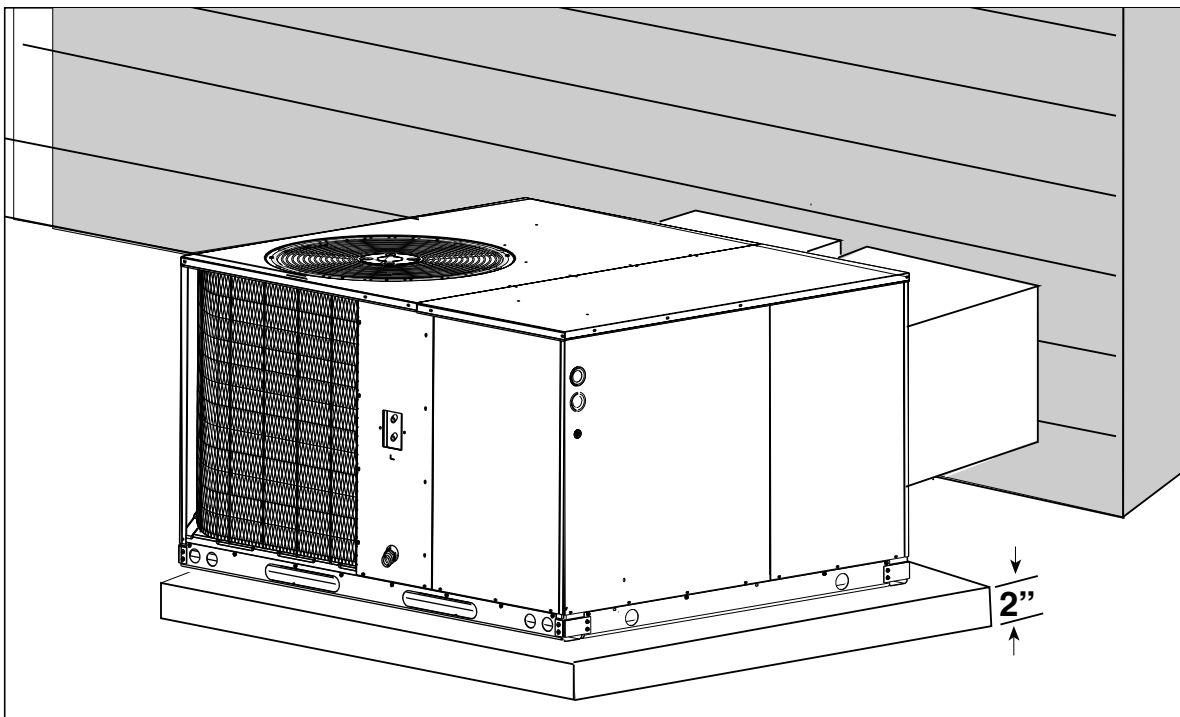

Figure 5. Ground Level Installation

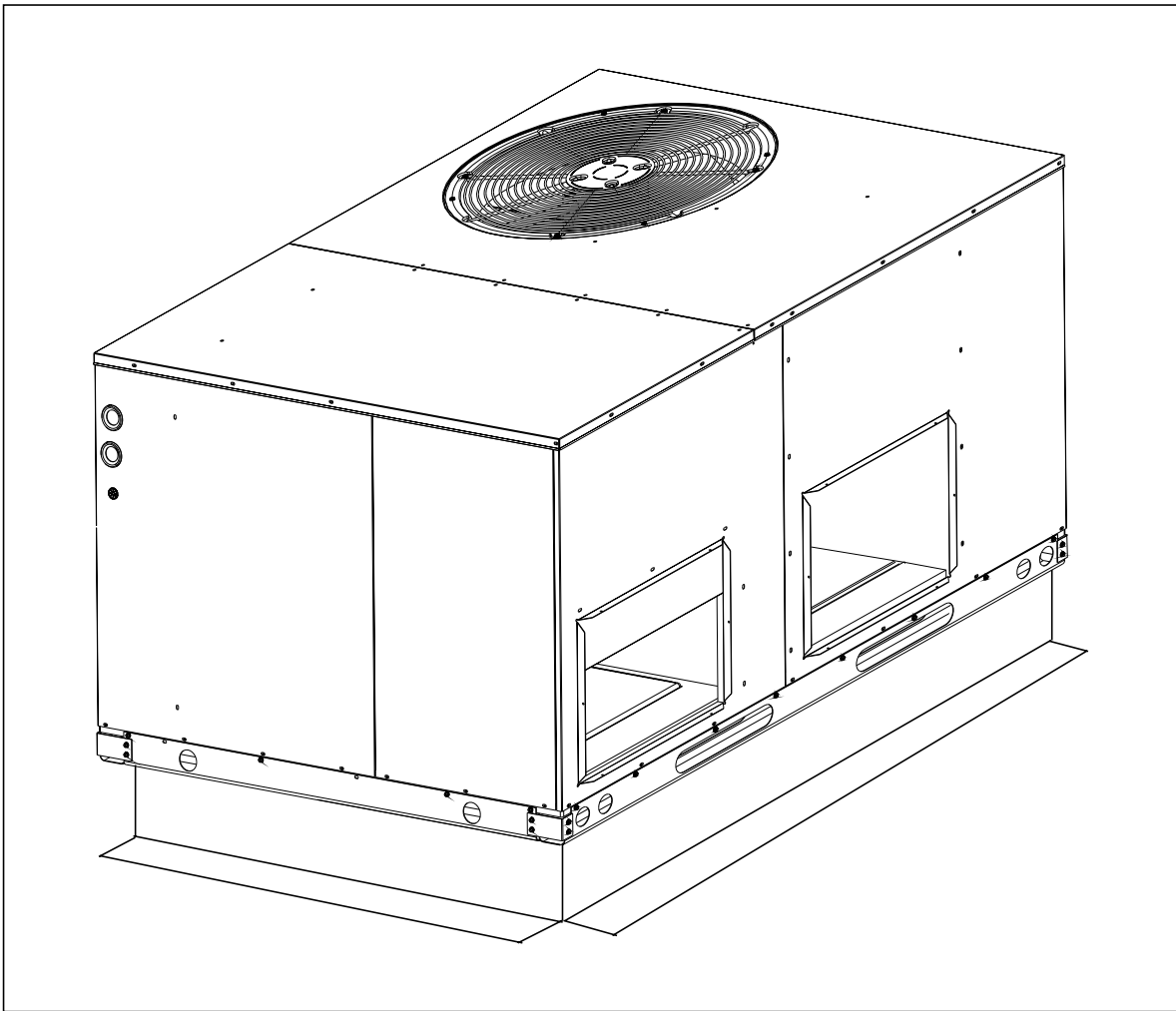

Figure 6. Roof Top Installation

Acoustical Duct Work — Certain installations may require the use of acoustical lining inside the supply duct work. Acoustical insulation must be in accordance with the current revision of the Sheet Metal and Air Conditioning Contractors National Association (SMACNA) application standard for duct liners. Duct lining must be UL classified batts or blankets with a fire hazard classification of FHC-25/50 or less. Fiber duct work may be used in place of internal duct liners if the fiber duct work is in accordance with the current revision of the SMACNA construction standard on fibrous glass ducts. Fibrous duct work and internal acoustical lining must be NFPA Class 1 air ducts when tested per UL Standard 181 for Class 1 ducts.

Horizontal to Down flow Conversion — The unit is shipped ready for horizontal duct connections. If down flow ducts are required, the unit must be converted following the steps below for both the supply and return ducts.

- 1) Locate the duct cap inside the duct openings and remove the screw holding it in place.
- 2) Lift the cap out of the unit. (The cap can be pushed up from the bottom by reaching through the fork slot).
- 3) Cover the horizontal duct opening with the cap. The insulation will be on the indoor side.
- 4) Fasten the cover with screws and seal to prevent air leakage.

Clearance — This unit is approved for 6 inch clearance.

ELECTRICAL WIRING

General — Electrical power wiring must be made in accordance with all applicable local codes and ordinances, and with the current revision of the National Electric Code NFPA 70 or in Canada CSA C.22.1 - Canadian Electrical Code Part 1. If any of the original wire as supplied with the unit must be replaced, it must be

replaced with material of the same gauge and temperature rating.

! WARNING:

To avoid risk of electrical shock, personal injury, or death, disconnect all electrical power to the unit before performing any maintenance or service. The unit may have more than one electrical supply.

Line Voltage — Before proceeding with the electrical connections, make certain that the voltage, frequency, and phase of the supply source are the same as those specified on the unit rating plate. Also verify that the service provided by the utility is sufficient to handle the additional load imposed by this equipment.

See the unit wiring label for proper high and low voltage wiring. Make all electrical connections in accordance with all applicable codes and ordinances.

Use a separate branch electrical circuit for this unit. A means of electrical disconnect must be located within sight of and readily accessibility to the unit. Internally mounted circuit breakers are available as field installed options. These circuit breakers can be used as an electrical disconnect.

The unit is shipped from the factory wired for 240 volt transformer operation. For 208 volt operation, remove the lead from the transformer terminal marked 240V and connect it to the terminal marked 208V. For maximum ampacity and over current protection, see the unit rating plate.

Provide power supply (or supplies) for the unit in accordance with the unit wiring diagram, and the unit rating plate. Connect the line-voltage leads to the corresponding terminals on the contactor (or the circuit breaker when the field installed circuit breaker kits are used) inside the control compartment. Use only copper wire for the line voltage power supply to this unit. Use proper code agency listed conduit and a conduit connector for connecting the supply wires to the unit and for obtaining proper grounding. Grounding may also be accomplished by using the grounding lug provided in the control box.

! WARNING:

The unit cabinet must have an uninterrupted or unbroken electrical ground to minimize personal injury if an electrical fault should occur. This ground may consist of electrical wire or approved conduit when installed in accordance with existing national or local codes.

Blower Speed — The blower speed is preset at the factory for operation at the same speed for heating and cooling. For optimum system performance and comfort, it may be necessary to change the factory set speed. To change the blower speed:

1. Disconnect all electrical power to the unit and remove the service panel.
2. Remove the motor lead from terminal #4 of the blower relay. Cut the wire tie holding the motor lead bundle. The motor leads are color coded as shown in **Figure 7**.

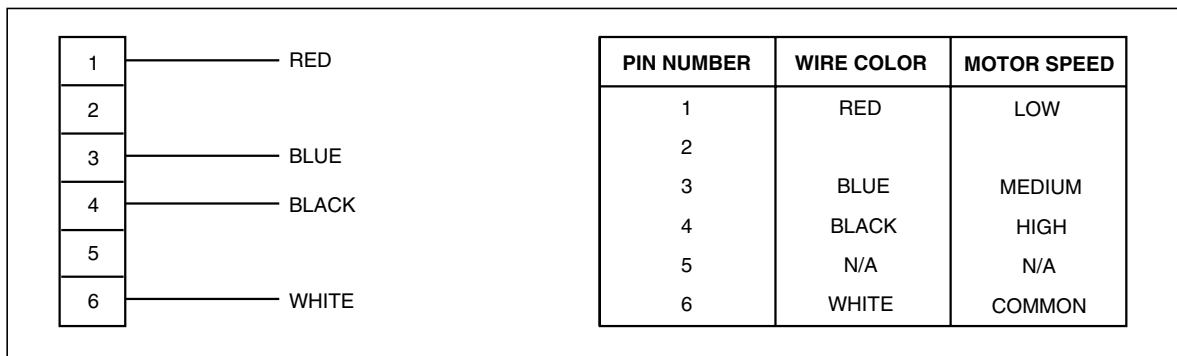

Figure 7. Motor Lead Connector

3. If the desired heating blower speed is different than the cooling speed, remove and discard the jumper wire between terminals #6 and #4. on the blower relay. Place the desired heating blower speed lead on terminal #6 and the desired cooling blower speed lead on terminal #4 of the blower relay. Use another wire tie (field supplied) to bundle the remaining motor leads.

Check all factory wiring per the unit wiring diagram and inspect the factory wiring connections to be sure none loosened during shipping or installation.

**CAUTION:**

To avoid personal injury or property damage, make certain that the motor leads cannot come into contact with any uninsulated metal components of the unit.

Low Voltage Connections

Room Thermostat — Several options are available for a room thermostat depending on the accessories installed with the unit. The available thermostats recommended for use with these units are listed with the accessories in **Table 1**. Select a thermostat which operates in conjunction with the installed accessories. The thermostat should be mounted about five feet above the ground on an inside wall. The thermostat should be kept away from drafts, slamming doors, lamps, direct sunlight, or in line with the supply air flow.

To install the thermostat:

1. Position the sub base on an inside wall and mark the mounting holes and thermostat cable openings.
2. Cut out the cable opening and route the thermostat cable from the unit's low voltage compartment to the thermostat location. The thermostat cable is supplied by the installer.
3. Connect the cable leads to the sub base or thermostat terminals and to the unit's low voltage pigtailed as shown in **Figure 8**.

A system wiring diagram is also provided on the inside of the control panel cover.

4. Secure sub base or thermostat to the wall using screws provided with the thermostat.
5. If sub base is used, install the correct thermostat housing to sub base.
6. Refer to thermostat instruction sheet for complete detailed mounting information.

Field Installed Electric Heat — This Packaged Air Conditioner is designed to allow optional electric heat to be field installed as required by the building's particular heating load. The options available for each unit are shown in the heater kit installation instructions.

Install the heater kits as directed by the installation instructions that come as part of the heater kit. Follow all cautions and warnings as directed.

START UP AND SYSTEM CHECK

Pre-Start Check List

- Verify that the unit is level to allow proper condensate drainage.
- Verify that there is free airflow to and from the outdoor coil and that all clearance requirements are met.
- Verify that the duct work is sealed to prevent air leakage.
- Verify that the line voltage power leads are securely connected and the unit is properly grounded.
- Verify that the low voltage wires are securely connected to the correct leads on the low voltage terminal strip.
- Verify that all exterior panels are replaced and securely fastened.
- Verify that the outdoor fan turns freely.
- Verify that the power supply branch circuit overcurrent protection is sized properly.
- Verify that the thermostat is wired correctly. The thermostat function switch should be set to "Off" and the thermostat fan switch should be set to "Auto".

Start-Up Procedure

Close all electrical disconnects to energize the system.

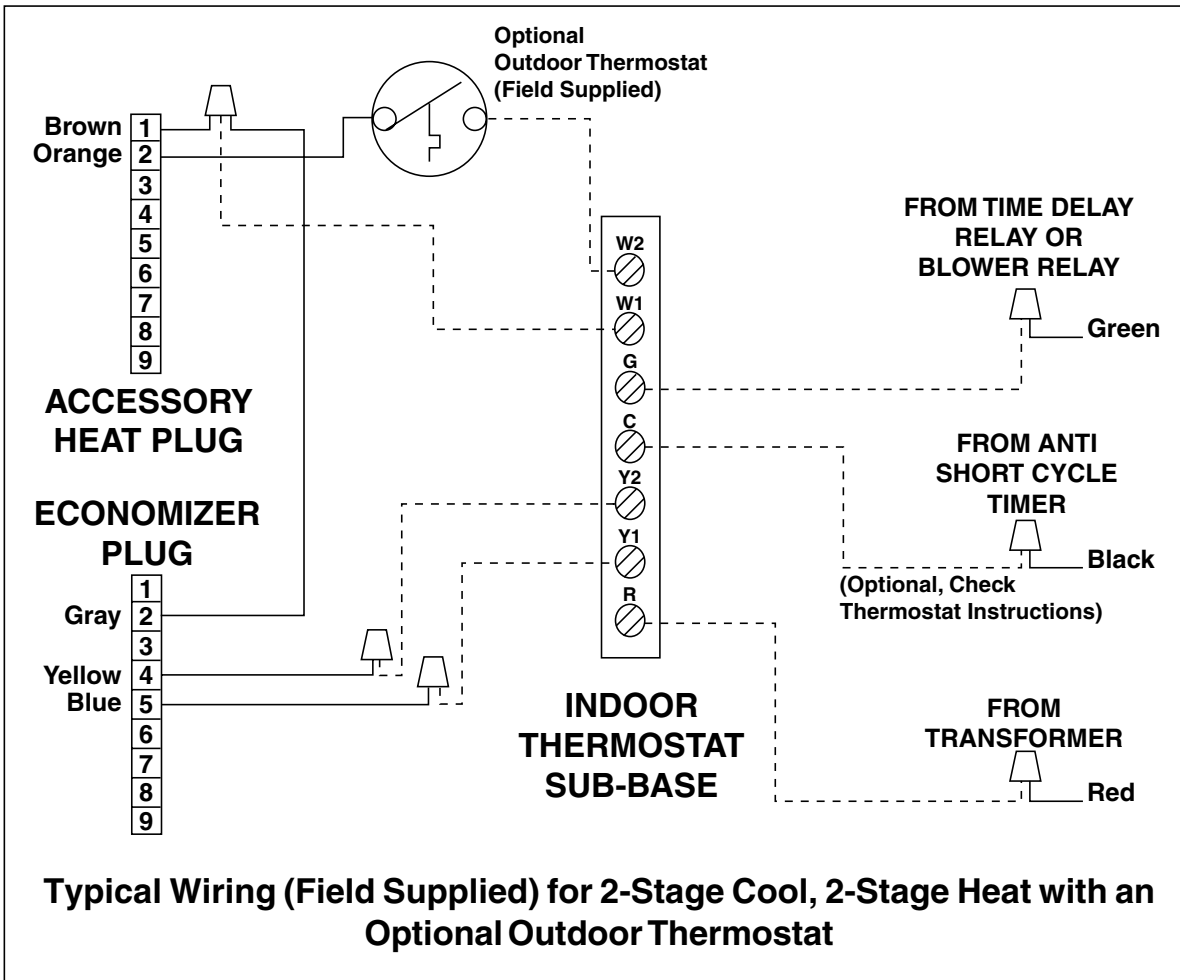
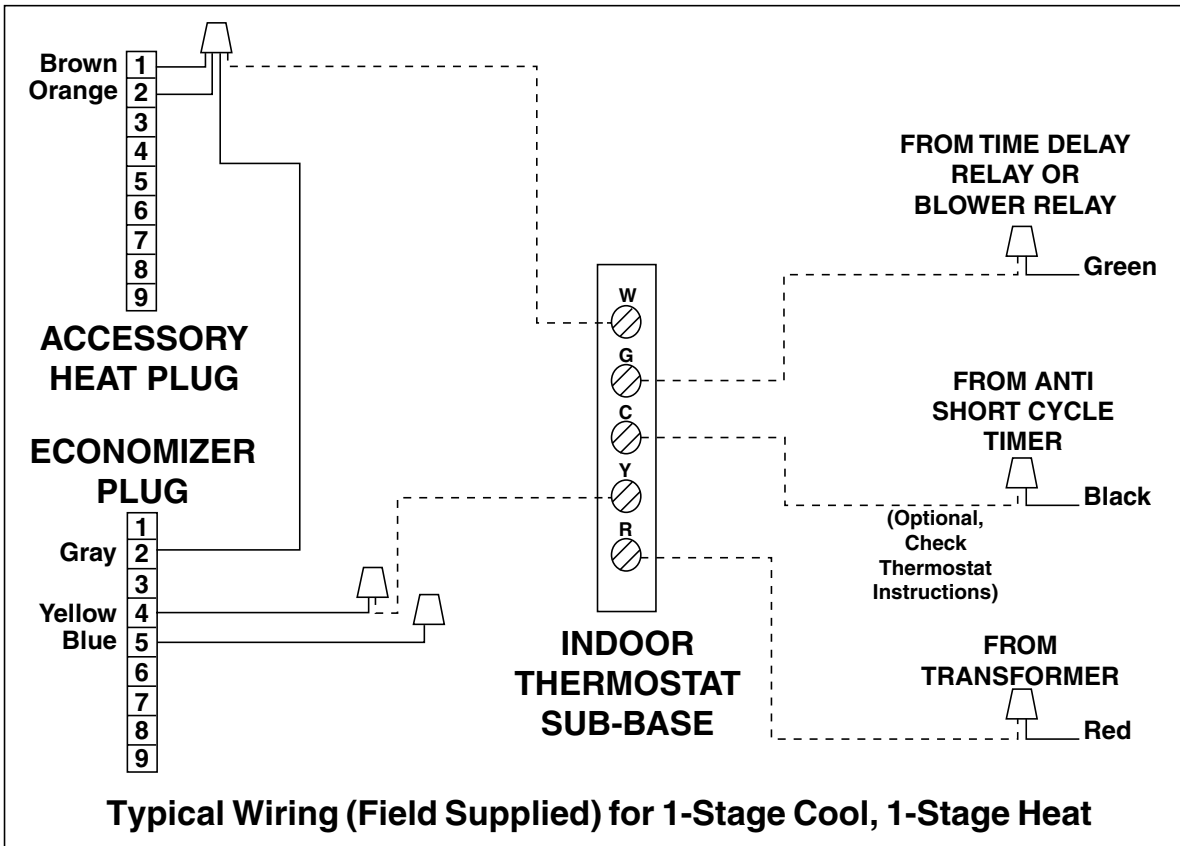

Figure 8. Typical Air Conditioner Thermostat Connections

 **WARNING:**

If the unit is equipped with a crankcase heater, allow 24 hours prior to continuing the start up procedures to allow for heating of the refrigerant compressor crankcase. Failure to comply may result in damage and could cause premature failure of the system. This warning should be followed at initial start up and any time the power has been removed for 12 hours or longer.

Air Circulation — Leave the thermostat system switch set to “Off” and set the thermostat fan switch to “On”. The blower motor should run continuously. Check for air delivery at the register(s). Ensure that there are no obstructions at the registers or in the duct work. Set thermostat fan switch to “Auto.”

Short Cycle Protection (Single Phase Units)

— With the system operating in cooling mode, note the temperature setting of the thermostat and gradually raise the set-point temperature until the unit de-energizes. Immediately lower the set point temperature of the thermostat to its original setting and verify that the indoor blower is energized. Verify that after approximately 5 minutes the compressor and fan energize and that the temperature of the discharge air is cooler than the room temperature.

System Cooling

1. Set the thermostat system switch to “Cool” and the thermostat fan switch to “Auto”. Gradually lower the thermostat temperature switch below room temperature and observe that the blower, compressor, and fan energize. Check that air cooler than room temperature is being discharged at the register. Listen for any unusual noises. Locate the source and correct as needed.
2. After allowing the unit to run for several minutes, set the temperature selector above room temperature.
 - The fan and compressor cycles off with the thermostat.
 - The blower should also stop unless fan switch is set to “ON” position.

System Heating — If the unit has been equipped with optional electric heater kits, set the system thermostat switch to HEAT and set the thermostat fan switch to AUTO. Verify that the compressor and outdoor fan are not energized but that the blower and heaters are. Check for warm air at the supply registers.

UNIT MAINTENANCE

 **WARNING:**

To avoid risk of electrical shock, personal injury, or death, disconnect all electrical power to the unit before performing any maintenance or service. The unit may have more than one electrical supply.

Refrigerant Charging — Packaged air conditioners are fully charged at the factory. The system refrigerant charge can be checked and adjusted through the service ports provided on the front panel. Use only gauge lines which have a “Schrader” depression device present to actuate the valve. Draw a vacuum on gauge lines to remove air before attaching them to the service ports on the unit. Refrigerant charging must be done by qualified personnel familiar with safe and environmentally responsible refrigerant handling procedures.

 **WARNING:**

Single Packaged Air Conditioners are shipped fully charged and ready for installation. When a system is installed according to these instructions, no refrigerant charging is required. If repairs make it necessary for evacuation and charging, it should only be done by qualified, trained personnel thoroughly familiar with this equipment. Some local codes require licensed installation/service personnel to service this type of equipment. Under no circumstances should the owner attempt to install and/or service this equipment. Failure to comply with this warning could result in property damage, personal injury, or death.

CAUTION:

Use care when removing parts from this unit. Personal injury can result from sharp metal edges present in all equipment of sheet metal construction.

Routine Maintenance — Proper maintenance is important to achieve optimum performance from the air conditioner. The ability to properly perform maintenance on this equipment requires certain mechanical skills and tools. If you do not possess these skills, contact your dealer for maintenance. Consult your local dealer about the availability of maintenance contracts. At a minimum, routine maintenance should include the following:

1. Inspect and clean or replace air filters at the beginning of each heating and cooling season, or more frequently if required.
2. Inspect the condensate drain and outdoor coil at the beginning of each cooling season. Remove any debris. Clean the outdoor coil and louvers as necessary using a mild detergent and water. Rinse thoroughly with water.

3. Inspect the electrical connections for tightness at the beginning of each heating and cooling season. Service as necessary.
4. Motors having oil tubes should be lubricated annually by adding 10 drops of SAE 20 non detergent oil. Do not over oil or lubricate any motor that does not have oil tubes.

CAUTION:

The unit should never be operated without a filter in the return air system. Replace disposable filters with the same type and size.

Model	Speed	External Static Pressure Drop - inches water column							
		0.1	0.2	0.3	0.4	0.5	0.6	0.7	0.8
3 Ton 10 SEER	High	1600	1510	1410	1310	1200	1070	930	760
	Medium	1410	1330	1250	1150	1050	940	820	670
	Low	1130	1070	1000	930	850	760	650	530
4 Ton 10 SEER	High	2000	1930	1850	1770	1690	1600	1510	1410
	Medium	1760	1700	1630	1560	1490	1410	1330	1250
	Low	1410	1360	1310	1250	1200	1130	1070	1000
5 Ton 10 SEER	High	2200	2140	2070	2000	1930	1850	1770	1690
	Medium	1940	1890	1830	1760	1700	1630	1560	1490
	Low	1560	1510	1460	1410	1360	1310	1250	1200
3 Ton 12 SEER	High	1600	1510	1410	1310	1200	1070	930	760
	Medium	1410	1330	1250	1150	1050	940	820	670
	Low	1130	1070	1000	930	850	760	650	530
4 Ton 12 SEER	High	2170	2100	2040	1960	1890	1810	1730	1650
	Medium	1910	1860	1800	1730	1670	1600	1530	1450
	Low	1540	1490	1440	1390	1340	1280	1220	1160
5 Ton 12 SEER	High	2200	2140	2070	2000	1930	1850	1770	1690
	Medium	1940	1890	1830	1760	1700	1630	1560	1490
	Low	1560	1510	1460	1410	1360	1310	1250	1200

 - Speed set at factory

Table 1. Packaged Air Conditioner Blower Curves

3 TON		OUTDOOR TEMPERATURE (°F)																	
		70		75		80		85		90		95		100		105			
		Suct. Pres.	Disch. Temp.	Disch. Pres.	Disch. Temp.	Disch. Pres.	Disch. Temp.	Disch. Pres.	Disch. Temp.	Disch. Pres.	Disch. Temp.	Disch. Pres.	Disch. Temp.	Disch. Pres.	Disch. Temp.	Disch. Pres.	Disch. Temp.		
74	203	158																	
76	204	172	218	163															
78	204	189	220	176	234	166	246	163	257	166									
80	205	206	221	191	235	179	249	169	261	174	272	170							
82	206	223	222	205	237	193	251	181	265	180	276	177	287	175					
84			223	219	239	205	253	196	267	189	280	183	292	181	302	180			
86					240	218	255	207	269	199	282	193	296	188	307	186			
88									271	210	285	203	298	197	311	193			
90													300	207	314	202			
92													303	216	316	211			
94														319	220	220			

- Shaded Boxes indicate flooded conditions

- Rated Design Values. Suction Pressure will be lower than design value if indoor air flow, entering dry bulb, or entering wetbulb temperatures are lower than design.

- Discharge temperatures greater than charted values indicates a refrigerant undercharge.

4 TON		OUTDOOR TEMPERATURE (°F)																	
		70		75		80		85		90		95		100		105			
		Suct. Pres.	Disch. Temp.	Disch. Pres.	Disch. Temp.	Disch. Pres.	Disch. Temp.	Disch. Pres.	Disch. Temp.	Disch. Pres.	Disch. Temp.	Disch. Pres.	Disch. Temp.	Disch. Pres.	Disch. Temp.	Disch. Pres.	Disch. Temp.		
70	201	117																	
72	203	120	216	128															
74	204	137	219	134	233	130	245	137	258	142									
76	204	154	220	148	235	144	250	139	262	150	275	149							
78	205	171	221	163	237	158	252	151	266	154	279	156	292	156					
80			222	177	238	170	254	166	268	163	283	161	296	162	310	163			
82					240	183	255	177	271	174	285	171	300	169	314	168			
84									273	184	288	181	303	178	317	177			
86													305	188	320	185			
88													307	197	322	194			
90														325	203	203			

* Note: All pressures are listed in psig and all temperatures in degrees F.

Table 2. 10 SEER Packaged Air Conditioner Charging Charts

5 TON		OUTDOOR TEMPERATURE (°F)																							
		70			75			80			85			90			95			100			105		
		Suct. Pres.	Disch. Temp.	Disch. Pres.	Suct. Pres.	Disch. Temp.	Disch. Pres.	Suct. Pres.	Disch. Temp.	Disch. Pres.	Suct. Pres.	Disch. Temp.	Disch. Pres.	Suct. Pres.	Disch. Temp.	Disch. Pres.	Suct. Pres.	Disch. Temp.	Disch. Pres.	Suct. Pres.	Disch. Temp.	Disch. Pres.			
70	200	146		202	155	217	157		220	166	236	161	250	166	265	172		283	180		302	187			
72	202	172		220	166	236	161	250	166	265	172		283	180		302	187		321	195		336	235		
74	202	189		221	180	238	175	255	169	269	180		292	192		310	200		325	201		331	217		
76	203	189		221	180	238	175	255	169	269	180		292	192		310	200		325	201		331	217		
78	204	206		222	195	240	188	257	182	273	185		294	202		313	209		329	208		334	226		
80				223	209	241	201	258	196	275	193		296	211		315	219		331	217		337	228		
82				243	214	260	208	277	204	294	202		315	219		331	217		334	226		336	235		
84																									
86																									
88																									
90																									

- Shaded Boxes indicate flooded conditions

- Rated Design Values. Suction Pressure will be lower than design value if indoor airflow, entering dry bulb, or entering wetbulb temperatures are lower than design.



- Discharge temperatures greater than charted values indicates a refrigerant undercharge.

Table 1 Continued. 10 SEER Packaged Air Conditioner Charging Charts

3 TON		OUTDOOR TEMPERATURE (°F)																							
		70			75			80			85			90			95			100			105		
		Suct. Pres.	Disch. Temp.	Disch. Pres.	Suct. Pres.	Disch. Temp.	Disch. Pres.	Suct. Pres.	Disch. Temp.	Disch. Pres.	Suct. Pres.	Disch. Temp.	Disch. Pres.	Suct. Pres.	Disch. Temp.	Disch. Pres.	Suct. Pres.	Disch. Temp.	Disch. Pres.	Suct. Pres.	Disch. Temp.	Disch. Pres.			
74	170	128		185	139		202	144	214	148	227	154		243	162		260	169		276	177				
76	172	137		187	149		203	158	218	153	230	162		247	168		264	175		281	183				
78	172	154		189	163		205	171	220	165	234	168		250	175		267	184		283	192				
80	173	171		190	177		207	184	222	179	236	177		253	185		269	193		286	201				
82	173	187		191	191		208	197	224	191	238	187		255	195		272	203		288	210				
84																									
86																									
88																									
90																									
92																									
94																									

Table 3. 12 SEER Packaged Air Conditioner Charging Charts

* Note: All pressures are listed in psig and all temperatures in degrees F.

 - Shaded Boxes indicate flooded conditions
 - Rated Design Values. Suction Pressure will be lower than design value if indoor air flow, entering dry bulb, or entering wetbulb temperatures are lower than design.
 - Discharge temperatures greater than charted values indicates a refrigerant undercharge.

4 TON	OUTDOOR TEMPERATURE (°F)															
	70		75		80		85		90		95		100		105	
	Suct. Pres.	Disch. Temp.	Disch. Pres.	Disch. Temp.	Disch. Pres.	Disch. Temp.	Disch. Pres.	Disch. Temp.	Disch. Pres.	Disch. Temp.	Disch. Pres.	Disch. Temp.	Disch. Pres.	Disch. Temp.	Disch. Pres.	Disch. Temp.
68	166	132														
70	168	139	181	142												
72	169	156	184	150	198	145	149	222	155							
74	169	173	185	164	200	158	152	226	163	238	162					
76	170	190	186	179	202	172	165	231	167	242	169	255	169			
78			188	193	203	185	179	233	176	247	174	259	175	271	177	
80					205	197	191	235	186	249	183	263	181	276	183	
82								237	197	252	193	266	191	280	189	
84												268	200	282	198	
86												271	210	285	207	
88														287	216	

5 TON	OUTDOOR TEMPERATURE (°F)															
	70		75		80		85		90		95		100		105	
	Suct. Pres.	Disch. Temp.	Disch. Pres.	Disch. Temp.	Disch. Pres.	Disch. Temp.	Disch. Pres.	Disch. Temp.	Disch. Pres.	Disch. Temp.	Disch. Pres.	Disch. Temp.	Disch. Pres.	Disch. Temp.	Disch. Pres.	Disch. Temp.
72	187	155														
74	189	166	204	162												
76	189	183	206	173	222	165	164	250	167							
78	190	200	207	188	224	179	170	254	175	267	172					
80	190	217	208	202	225	192	182	257	182	271	179	285	177			
82			210	216	227	205	197	259	191	275	186	289	183	303	182	
84					228	218	208	261	201	277	196	292	192	308	188	
86								263	212	279	206	295	201	310	197	
88												297	211	313	206	
90												299	220	315	215	
92														318	224	

* Note: All pressures are listed in psig and all temperatures in degrees F.

Table 3 Continued. 12 SEER Packaged Air Conditioner Charging Charts

**INSTALLER:
PLEASE LEAVE THESE
INSTALLATION**

