

USER'S MANUAL & INSTALLATION INSTRUCTIONS

10 and 12 SEER

Single Package Heat Pump

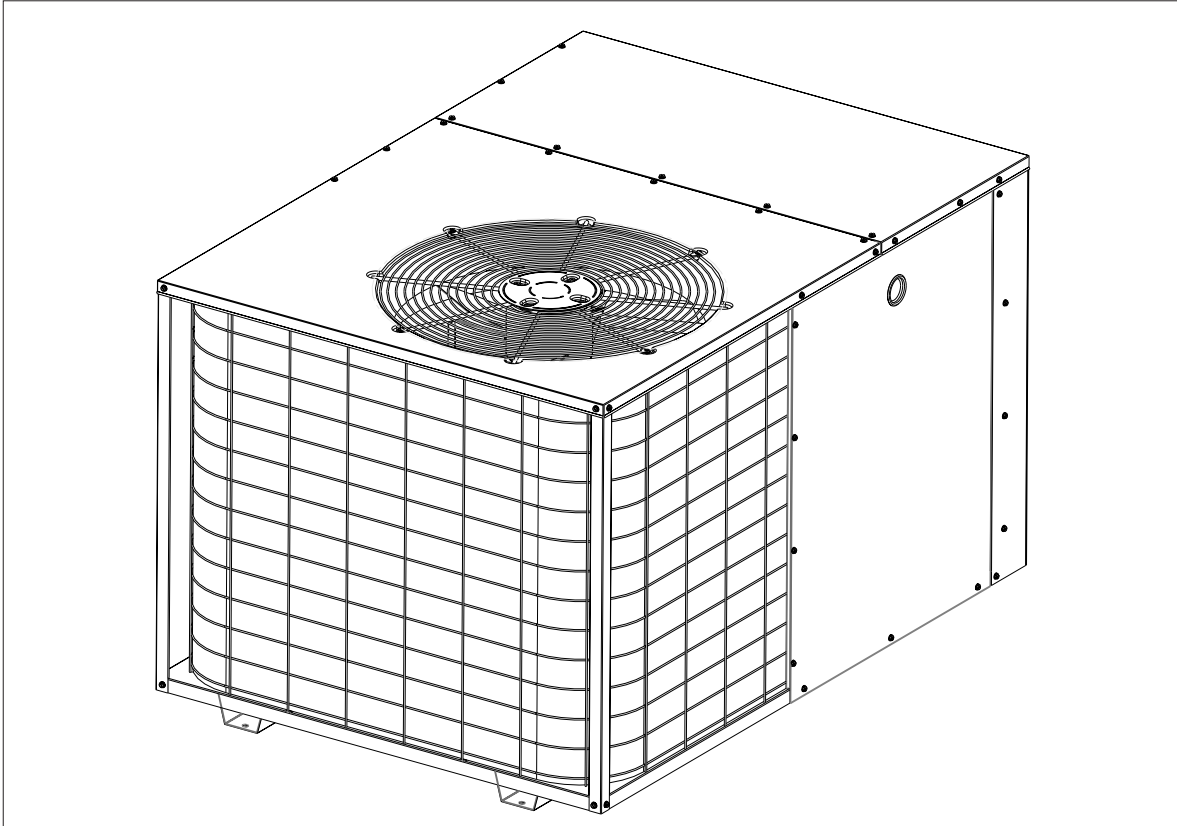

Single Package Heat Pump

IMPORTANT:

Read this owner information to become familiar with the capabilities and use of your appliance. Keep this with literature on other appliances where you have easy access to it in the future. If a problem occurs, check the instructions and follow recommendations given. If these suggestions don't eliminate your problem, call your installing contractor or distributor in your area.

INTRODUCTION

Your heat pump is a unique, all weather comfort-control system appliance. The basic operation of the heating/cooling system is described and illustrated on page 1 of this manual. The surprising fact that heat exists in air even at below-freezing temperatures is actually the basic law of physics which the heat pump uses to provide energy saving heating comfort. At outdoor temperatures of 47° Fahrenheit or (or

8° Celsius), your heat pump can deliver approximately 2 to 3 units of heat energy per each unit of electrical energy used, as compared to a maximum of only 1 unit of heat energy produced with conventional heating systems. During the cooling season, the heat pump reverses the flow of the heat-absorbing refrigerant to become an energy-efficient, central air conditioner.

SECTION 1. OWNER INFORMATION

Your heat pump will heat and cool your home year round, saving your energy dollars. During the summer, a heat pump performs like any normal air conditioner. That is, the excess heat energy inside the home is absorbed by the refrigerant and exhausted outside the home. During the winter months, a heat pump performs like an air conditioner run in reverse. That is, available heat energy outside the home is absorbed by the refrigerant and exhausted inside the home. This is an efficient heating means because you only pay for “moving” the heat from the outdoors to the indoor area. You do not pay to generate the heat, as is the case with more traditional furnace designs.

It is the sole responsibility of the homeowner to make certain that the heat pump has been correctly set up and adjusted to operate properly.

The manufacturer warrants the heat pump to be free from defects in workmanship or material for a period of one year. A warranty certificate with full details is included with the heat pump. However, we will not be responsible for any costs found necessary to correct problems due to improper setup, improper installation, adjustments, improper operating procedure on the part of the user, etc.

Some specific examples of service calls which are not included in the limited warranty are:

1. Correcting wiring problems in the electrical circuit supplying the heat pump.
2. Resetting circuit breakers or other switches.
3. Adjusting or calibrating of thermostat.

To avoid misunderstandings at a later date, carefully review these responsibilities with your dealer or service company.

OPERATING INSTRUCTIONS

To Operate Your Heat Pump For Cooling —

1. Set the thermostat system switch to COOL and the thermostat fan switch to AUTO. (See Figure 1)
2. Set the thermostat temperature selector to the desired cooling temperature. The outdoor unit fan, the indoor blower, and the compressor will all cycle on and off to maintain the indoor temperature at the desired cooling level.

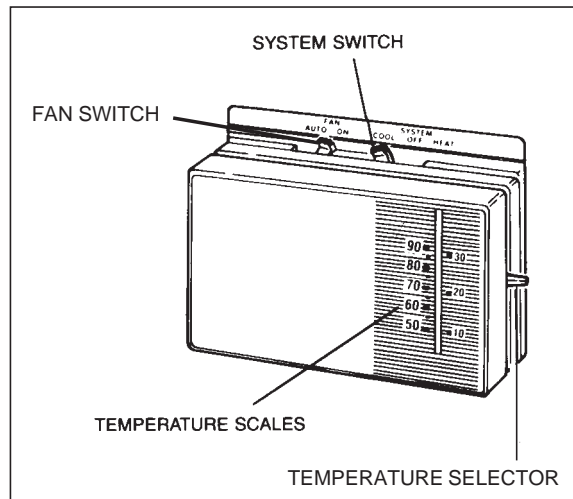

Figure 1. Typical Thermostat

NOTE: If the thermostat temperature level is re-adjusted, or if the thermostat system switch is re-positioned, the outdoor unit fan and the compressor may not start immediately. A protective timer circuit holds the compressor and the outdoor fan off for approximately five minutes following a previous operation or the interruption of the main electric power.

To Operate Your Heat Pump For Heating —

1. Set the thermostat system switch for HEAT and the thermostat fan switch to AUTO. (See Figure 1)
2. Set the thermostat temperature selector to the desired heating temperature. The outdoor unit fan, the indoor blower, and the compressor will all cycle on and off to maintain the indoor temperature at the desired heating level.

NOTE: If the thermostat temperature level is re-adjusted, or if the thermostat system switch is re-positioned, the outdoor unit fan and the compressor may not start immediately. A protective timer circuit holds the compressor and the outdoor fan off for approximately five minutes following a previous operation or the interruption of the main electrical power.

Emergency Heat — Some thermostats will include a system switch position termed EM HT or AUX HT, etc. This is a back-up heating mode to be used only if there is a suspected problem. With the system switch set to EM HT, etc., the compressor and outdoor fan will be locked off and supplemental heat (electric resistance

heating) will be used as a source of heat. Sustained use of electric resistance heat in place of the heat pump will result in an increase in electric utility costs.

Defrost — During cold weather heating operation, the outdoor unit will develop a coating of snow and ice on the heat transfer coil. This is normal and the unit will periodically defrost itself. During the defrost cycle, the outdoor fan will stop, while the compressor continues to run and heat the outdoor coil, causing the snow and ice to melt. During defrost, there may be some steam rise from the outdoor unit as the warm coil causes some melted frost to evaporate.

SECTION 2. INSTALLER INFORMATION

GENERAL

Read the following instructions completely before performing the installation.

These instructions are for the use of qualified personnel specially trained and experienced in the installation of this type of equipment and related system components. Some states require installation and service personnel to be licensed. Unqualified individuals should not attempt to interpret these instructions or install this equipment.

The single packaged air conditioners are designed for outdoor installation only and can be readily connected into the high static duct system of a home. The only connections needed for installation are the supply and return ducts, the line voltage, and thermostat wiring. A complete air conditioning system typically consists of:

- Single Package Heat Pump
- Home Fittings Kit
- Unit Fittings Kit
- Thermostat

The single package air conditioner is completely assembled, factory wired, and factory run tested. The units are ready for easy and immediate installation.

Use of components other than those specified may invalidate ARI Certification, Code Agency Listing, and limited warranty on the air conditioner.

PRE-INSTALLATION CHECK

Before any installation is attempted, the cooling load of the area to be conditioned must be

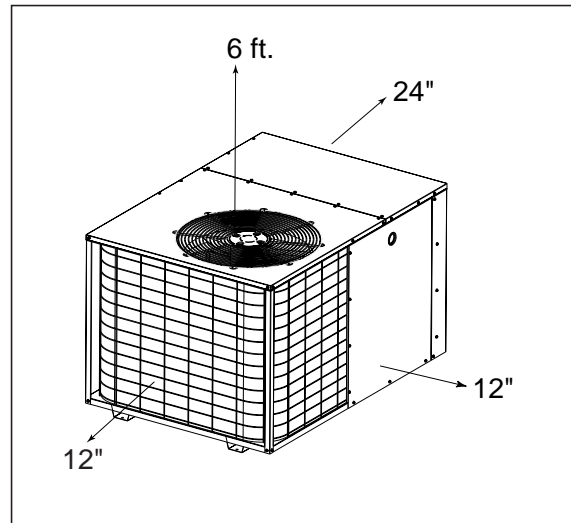

Figure 2. Minimum Unit Clearances

calculated and a system of the proper capacity selected. It is recommended that the area to be conditioned be completely insulated and vapor sealed.

The installer should comply with all local codes and regulations which govern the installation of this type of equipment. Local codes and regulations take precedence over any recommendations contained in these instructions. Consult local building codes and the National Electrical Code (ANSI C1) for special installation requirements.

The electrical supply should be checked to determine if adequate power is available. If there is any question concerning the power supply, contact the local power company.

Inspecting Equipment: All units are securely packed at the time of shipment and, upon arrival, should be carefully inspected for damage. Claims for damage (apparent or concealed) should be filed immediately with the carrier.

INSTALLATION

1. SELECT THE BEST LOCATION FOR THE HEAT PUMP UNIT

IMPORTANT: DO NOT PLACE UNIT UNDER THE HOME.

- Select a solid, level position, preferably on a concrete slab, slightly above the grade level, and parallel to the home.
- The hot condenser air must be discharged up and away from the home, and if possible, in a direction with the prevailing wind.

- Do not place the unit in a confined space.
- If practical, place the heat pump where it and the ducts will be shaded from the afternoon sun when the heat load is greatest.
- Try to select a site for the unit that is as close as possible to the proposed return grille location.
- Keep in mind that the length of the supply and return ducts should be kept to a minimum with no sharp radiused bends.

2. UNPACK THE UNIT

It is recommended that the unit be unpacked at the installation site to minimize damage due to handling.

! CAUTION:

Do not tip the unit on its side. Oil may enter the compressor cylinders and cause starting trouble. If unit has been set on its side, restore to upright position and do not run for several hours. Then run unit for a few seconds. Do this three or four times with five minutes between runs.

- Remove the bands from around the unit.
- Unfold the top and bottom cap flanges.
- Carefully remove the top cap and tube.

3. INSTALL THE RETURN AND SUPPLY AIR FITTINGS ON THE UNIT

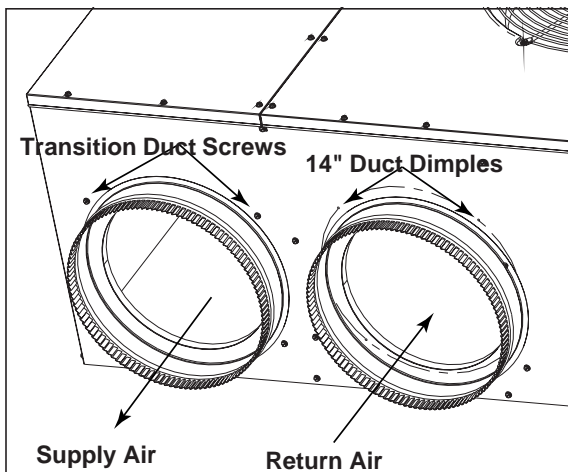

Figure 3. Return and Supply Air Fittings

The supply and return fittings are included with select models. If supplied, the duct fittings are shipped in the supply duct. They attach to the unit openings with a flange and bead arrangement, secured with two sheet metal screws. Note: For ease of access, install fitting before positioning unit in final location.

SUPPLY DUCT

Position the supply duct collar, if supplied, so the edge of the unit opening fits between the flange and the bead. Overlap the collar ends keeping the small screw holes underneath. Align the holes in the crimped area and install one screw.

Note: It may be necessary to loosen the four screws that hold the transition duct in order to install the supply fitting. Re-tighten when installation is complete.

Tap collar as necessary to ensure engagement with unit opening and install second screw. Tighten first screw. Rotate collar clockwise so joint is near three o'clock position.

RETURN DUCT

The 12" return duct is installed in the same manner as the supply duct. If the duct has a 14" return, follow these instructions.

Align the slots with the holes in the collar and install two screws. Position the collar over the opening and align the four notches in the collar with the four dimples in the panel. Using self-drilling screws (10-16x.5) attach the collar to the rear panel. On some models a 14" duct collar is provided for the return duct.

4. LOCATING AND INSTALLING THE RETURN AIR ASSEMBLY

To avoid complications, locate and install the return air assembly first. The return air box with grille and filter (Figure 4) should not be located in heavy traffic areas like hallways or center of rooms. A good spot is in a corner or under a table, if a minimum two inch clearance is available. If desired, the return opening can be

10 SEER Model	Return Dia. (in)
2 Ton	12
2 1/2 Ton	12
3 Ton	12
3 1/2 Ton	12
4 Ton	14
5 Ton	14

12 SEER Model	Return Dia. (in)
2 Ton	12
2 1/2 Ton	12
3 Ton	12
3 1/2 Ton	14
4 Ton	14

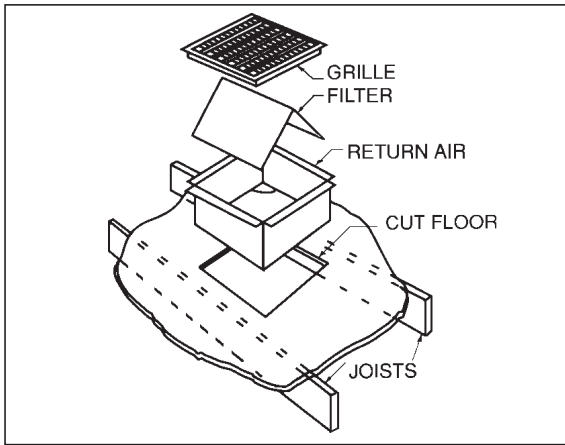

Figure 4. Return Air Box

located inside a closet with louvered doors that have an open area equal to or greater than the 12" x 20" grille furnished. The return air grille can be placed in the wall of a closet and the air ducted into the filter box through a boxed-in area at the closet floor level. Make sure the filter is readily accessible.

After determining the location of the return air opening, start the installation from under the home by cutting a small hole in the fiber underboard to determine how the floor joist location will affect cutting the opening needed for the box. Floor joists generally are located on 16" centers, leaving 14-3/8" between joists. After measuring the return air box (approximately 12-1/4" x 20-1/4"), cut the hole through the floor so that the box will fit between the floor joists. Care should be taken when cutting through carpeting to avoid snags. In most installations it will be necessary to cut a similar hole in the fiberboard directly under the hole in the floor. However, if the floor is more than ten inches deep, it will only be necessary to cut a hole for the collar on the return air box or for the insulated duct.

Set the box into the opening and fasten with screws or nails. Put the filter and return air grille in place.

5. LOCATING AND INSTALLING THE SUPPLY DAMPER(S)

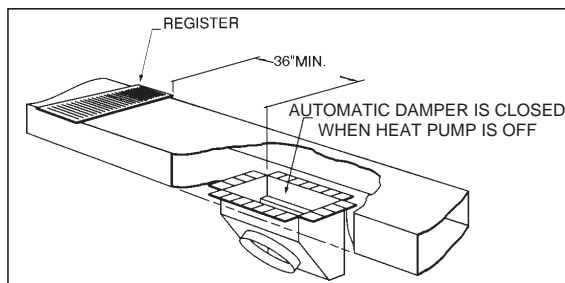

Figure 5. Supply Damper

When locating the supply damper(s), carefully check floor joists and frame members that could interfere with the installation of the damper or flexible duct. Ideally, the damper should be located in the bottom of the main duct, forward of center of the home, at least three feet from the nearest register. The round supply opening in the slanted side of the damper should face the side of the home where the heat pump is located. To locate the center of the heat duct, first cut a small hole in the fiberboard below the duct at the desired location. After locating the duct center, cut a hole approximately 3/4" larger than the damper opening in the fiberboard. Cut a 9-1/8" x 13-1/8" hole in the duct and bend over all tabs flat on the inside of the heat duct. After inserting the damper into the duct, bend over all tabs flat on the inside of the heat duct. Seal the opening between the fiberboard and damper or flexible duct.

DUCTING SYSTEM

DUCT REQUIREMENTS

The supply duct system, including the number and type of registers, will have much more effect on the performance the system than any other factor. The duct must be sufficiently large to conduct an adequate amount of air to each register.

THE HEAT PUMP SYSTEM WILL NOT COOL OR HEAT THE HOME IF THE AIR IS LOST TO THE OUTSIDE THROUGH LEAKS IN THE DUCT SYSTEM. ALSO, DUCTS WHICH ARE COLLAPSED OR RESTRICTED BY FOREIGN OBJECTS WILL PREVENT ADEQUATE AIR FLOW.

Note: For highly resistive duct systems it may be necessary to add an additional return air duct to achieve maximum performance.

CONNECTING THE RETURN AND SUPPLY AIR FLEXIBLE DUCTS

The return duct may be 12" or 14" diameter depending on unit size. (See Table on page 4)

- The supply duct for all units is twelve inches in diameter.
- The flexible ducts can be connected to the corresponding fittings with the clamps provided with the ducts. Note: All connections should be leak tight or a loss in cooling capacity will result.

- c. The flexible ducts may be cut to the required length, see instructions packed with duct. Keep all ducts as short and straight as possible. Avoid sharp bends.
- d. Ducts may be spliced with sheet metal sleeves and clamps. (See Ducting Installation Accessories below.)
- e. Once the inner duct is connected to the proper fitting, the insulation and plastic sleeve should be pulled over the connection and clamped.
- f. For homes with multiple supply ducts or for special applications, a Y fitting is available to divide the supply air so it can be ducted to different areas of the home for more efficient cooling. Note: The Y fitting should be insulated for maximum performance.

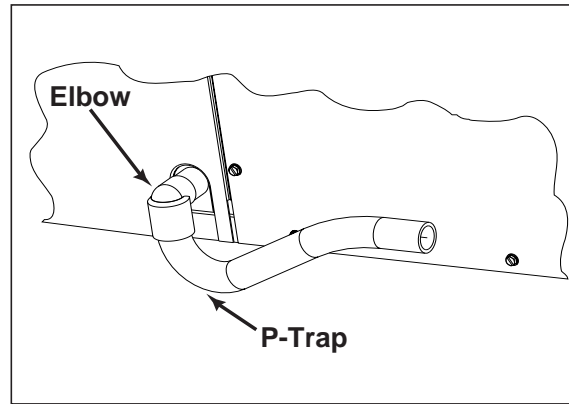

Figure 6. Drain Trap

Blower Speed — The blower speed is preset at the factory for operation at the same speed for heating and cooling. For optimum system

performance and comfort, it may be necessary to change the factory set speed. To change the blower speed:

1. Disconnect all electrical power to the unit and remove the service panel.
2. See figure 8 for wire color vs. motor speed guide.

TYPICAL APPLICATIONS

SINGLE DUCT APPLICATION

MULTIPLE DUCT APPLICATION

Ref. No.	Description
①	12" x 20" Return Air
②	16" x 20" Air Filter
③	12" x 20" Grille
④	Supply Damper
⑤	12" or 14" Diameter Flex Return Duct
⑥	12" Diameter Flex Supply Duct
⑦	12" x 12" x 12" "Y" Fitting

Figure 7. Typical Applications

- Place the desired blower speed lead on the "NO" terminal of the blower relay. Use another wire tie (field supplied) to bundle the remaining motor lead up and out of the way.

! CAUTION:

To avoid personal injury or property damage, make certain that the motor leads cannot come into contact with any uninsulated metal components of the unit.

Check all factory wiring per the unit wiring diagram and inspect the factory wiring connections to be sure none loosened during shipping or installation.

<u>Wire Color</u>	<u>Motor Speed</u>
Black	High
Red	Low

Figure 8. Motor Lead Connection

CONDENSATE DRAIN

A 3/4" condensate fitting extends out of the side of the unit. The drain trap, shipped in the electrical compartment, must be installed to prevent water from collecting inside the unit. Thread the elbow provided with the unit into the drain connection until hand tight. Install the trap into the fitting making sure it is level. Route the condensate from the trap to a suitable drain. Any tubing or hose connected must have the outlet below trap level for proper drainage.

! WARNING:

Turn off electrical power before servicing controls. Severe electrical shock may result unless power is turned off. Unit must be installed in compliance with the National Electrical Code (NEC) and local codes.

ELECTRICAL CONNECTIONS

1. ELECTRICAL SERVICE

High Voltage

- Install a branch circuit disconnect of adequate size per NEC. Locate the disconnect within sight of the unit.
- Extend leads through power wiring hole provided. Connect L1 and L2 directly to the contactor. (See Figure 9.)
- Ground the heat pump unit using the green grounding screw provided in the control panel.

Low Voltage

- Route 24v control wires through the sealing grommet near the power entrance. (See Figure 9.)
- Connect the control wires to the defrost board and blower relay wire. (See Figure 10.)

2. OVERCURRENT PROTECTION

In general, the best fuse or breaker for any heat

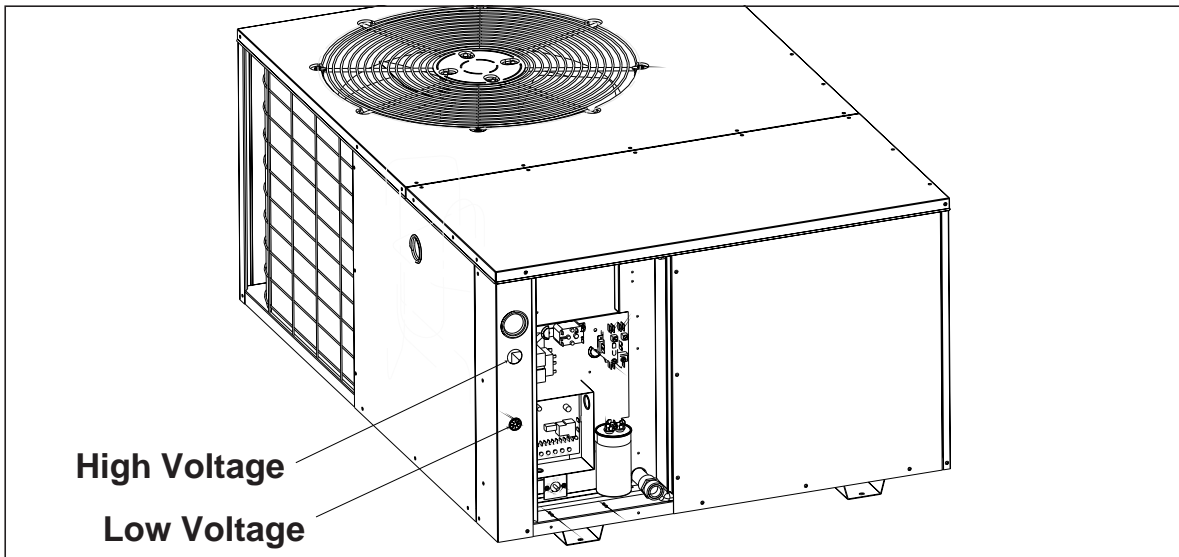

Figure 9. Power Entry

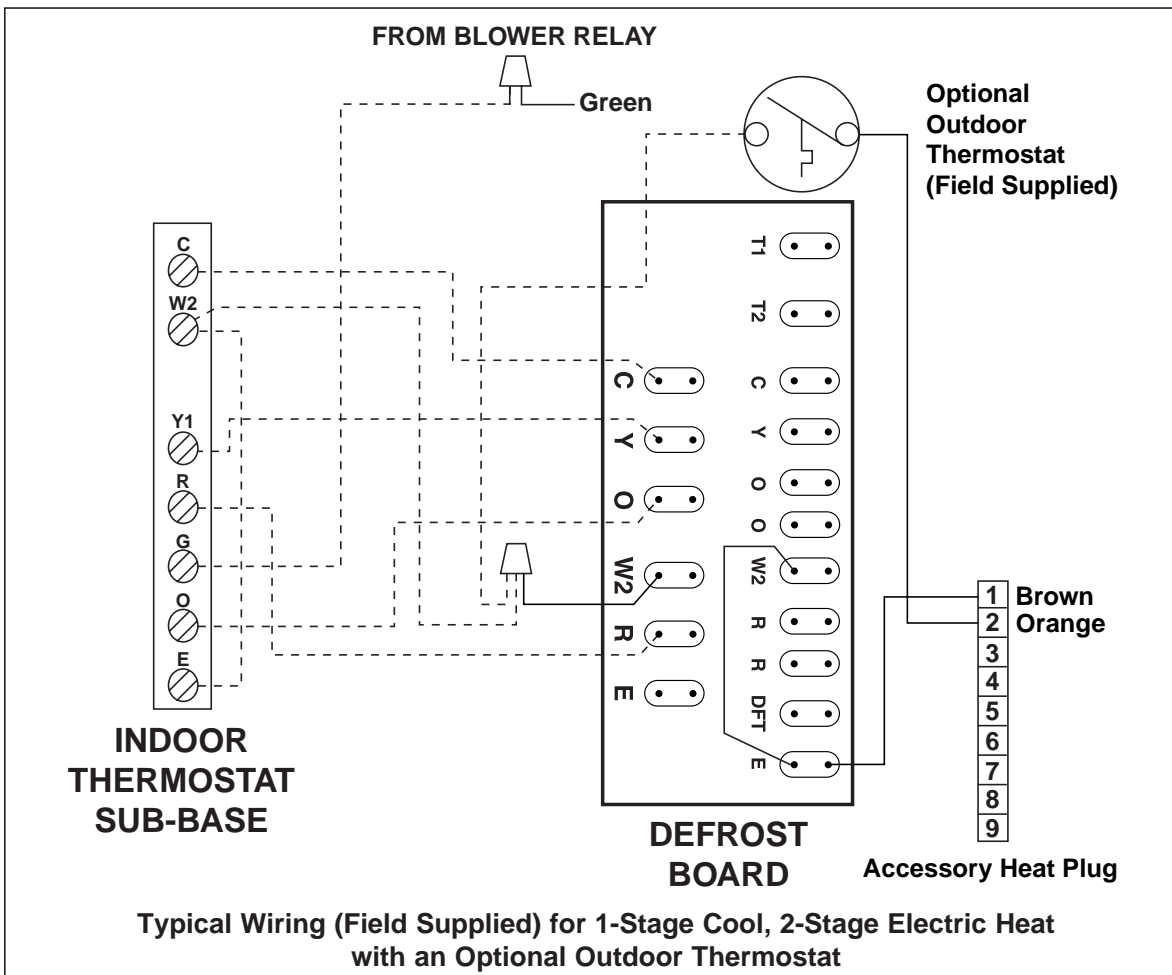
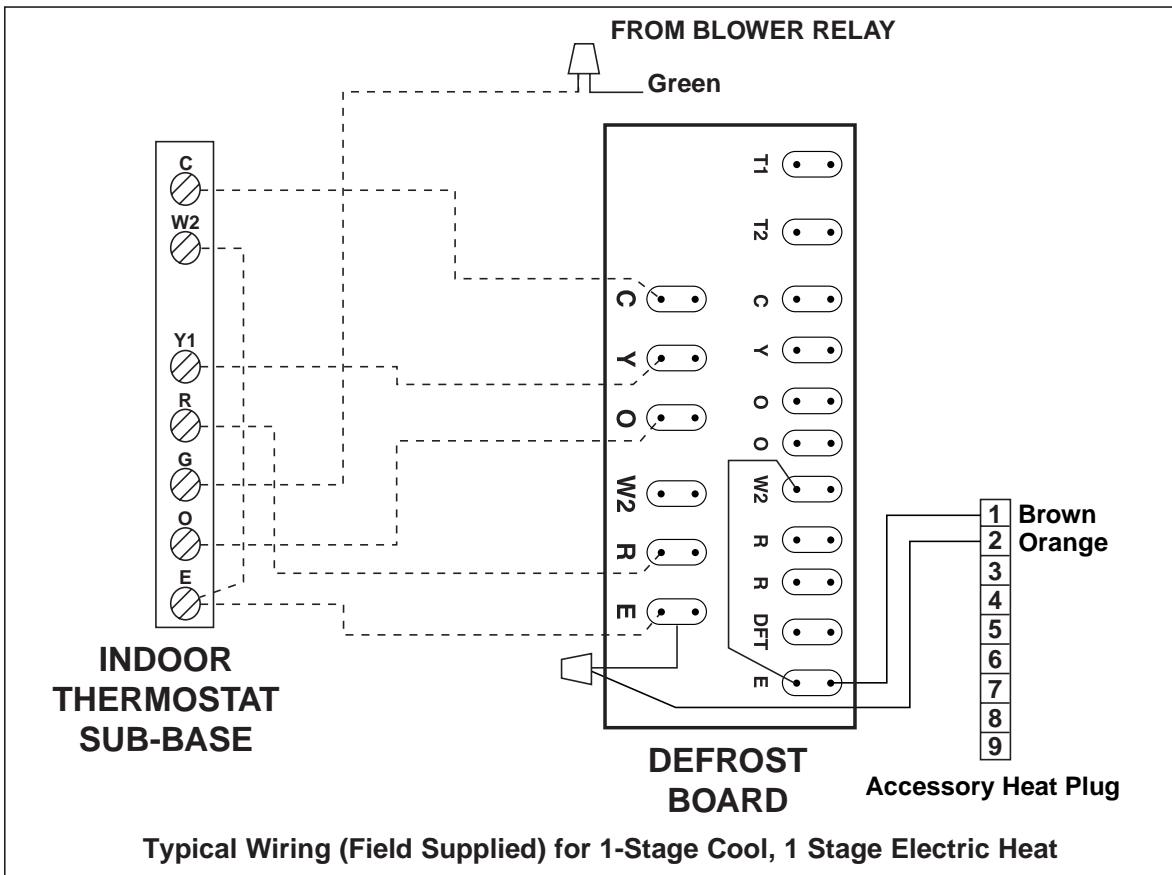

Figure 10. Typical Heat Pump Thermostat Connections

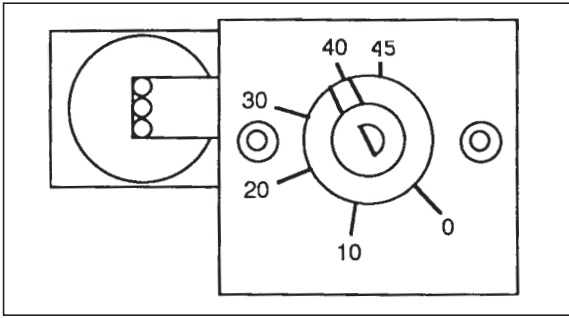

Figure 11. Outdoor Thermostat

pump is the smallest size that will permit the equipment to run under normal use and service without nuisance trips. Such a device, sized properly, gives maximum equipment protection. The principal reason for specifying a time delay type is to prevent nuisance trips when the unit starts.

In the event that a fuse does blow or a breaker trips, always determine the reason. Do not arbitrarily put in a larger fuse or breaker and do not, in any case, exceed the maximum size listed on the data label of the unit.

3. LOCATING THE THERMOSTAT

Locate the thermostat away from drafts and slamming doors and place it where there is a free flow of air. Mount on an inside wall approximately five feet from the floor.

Do not locate near a lamp, kitchen range, direct sunlight, or in line with air flow from supply registers.

Connect the Heat-Cool Thermostat: The heat-cool thermostat is equipped with a system HEAT-COOL switch, which provides a positive means of preventing simultaneous operation of the heating and cooling units. The thermostat is also equipped with an ON-AUTO fan switch which allows the home owner to operate the indoor blower when air circulation is desired.

Connect the low voltage wires to the respective terminals on the thermostat base. See thermostat instruction sheet for more detailed information. (See Figure 10).

If two stage heating is desired, an optional outdoor thermostat may be installed: Connect the thermostat to the orange low voltage wire and the W terminal on the indoor thermostat base (See Figure 10). See the ther-

mostat instructions for details on setting the outdoor thermostat.

4. DEFROST CYCLE CONTROL

The defrost cycle is initiated via a signal from the defrost sensor on the outdoor coil to the defrost control board inside the control panel indicating the coil temperature is low enough to start accumulating frost. The board has interval settings of 30 minutes, 60 minutes, and 90 minutes. These time intervals represent the time elapsed before defrosting cycle starts and they are dependent on the climate conditions of the installation. A 30 minute setting would be recommended in a moist climate such as Seattle, Washington. A 90 minute setting would be adequate in a dry climate such as southern Arizona. The factory time interval setting is 30 minutes.

5. OUTDOOR THERMOSTAT (if supplied)

The outdoor thermostat prevents the electrical auxiliary heat (if used) from operating above a desired set point. Selection of the set point is determined from the building design heat load.

The thermostat is adjustable from 45°F to 0°F. The factory temperature setting is at 40°F.

6. ELECTRIC HEAT PACKAGE (OPTIONAL)

The heat pumps are shipped without an auxiliary electric heat kit installed. If electric heat is desired, an accessory Heater Kit must be field installed. See Specifications Sheet for available kits and their application.

- Select the correct size heat package for the installation.
- Follow installation instructions provided with each heater kit.
- Installation is most easily accomplished before making duct or electrical connections.
- Blower speed must be set to high speed for electric heat operation.

SYSTEM OPERATION

1. PRE-START CHECK LIST

The following check list should be observed prior to starting the unit.

- Is the unit level? It should be level or slightly slanted toward the drain for proper condensate drainage.
- Is there free air flow to and from the condenser? A one foot clearance around the coil, and three foot clearance above the fan?
- Is the wiring correct according to the wiring diagram and electrical codes?
- Are all the wiring connections tight? Check the condenser fan to make sure it turns freely.
- Is the overcurrent protection properly sized?
- Is the thermostat wired correctly? Is it installed in a proper location?

- b. System Heating** — Set the thermostat system switch to HEAT and set the thermostat fan switch to AUTO. Position the thermostat temperature selector above the existing room temperature and check for the discharge of warm air at the supply registers.
- c. System Cooling** — Set the thermostat system switch to COOL and set the thermostat fan switch to AUTO. Position the thermostat temperature selector below the existing room temperature. Allow the cooling system to operate for several minutes and check for the discharge of cool air at the supply registers.
- d. Short cycle protection** — The control circuit is equipped with a time-delay feature for protection against short cycling. With the system operating in the cooling mode, gradually raise the thermostat temperature setting until the whole system de-energizes. Immediately lower the thermostat temperature to the original setting and verify that the indoor blower is energized. After approximately 5 minutes the compressor and the outdoor fan will energize.

2. START-UP PROCEDURE

The control circuit consists of an anti-short cycle timer that will not let compressor re-start before five (5) minutes have elapsed.

Set the thermostat system switch to OFF, and the thermostat fan switch to AUTO. Apply power at the disconnect switch and check the system operations:

- a. Air Circulation** — Leave the thermostat system switch at OFF, and set the thermostat fan switch to ON. Blower should run continuously. Check the air delivery at the supply registers and adjust register openings for balanced air distribution. Examine ductwork for leaks or obstruction if insufficient air is detected.

Set the thermostat fan switch to AUTO; the blower should stop running.

- e. Emergency Heat** — (Available only when Electric heat is supplied) Set the thermostat system switch to EM HT and set the thermostat fan switch to either AUTO (intermittent air) or to ON (continuous air). Position the thermostat temperature selector above the existing room temperature and check the following:
 1. The thermostat auxiliary heat light (RED) should be on.
 2. The heat pump compressor and the fan should not run; low voltage circuit remains energized.
 3. The blower will run according to the thermostat fan switch setting.

10 SEER - Refrigerant Charging Tables for Heating Mode of Operation

2 Ton

OUTDOOR TEMPERATURE (DEG. F)																				
0			10			20			30			40			50			60		
Suc. Press.	Disch. Press.	Disch. Temp.	Suc. Press.	Disch. Press.	Disch. Temp.	Suc. Press.	Disch. Press.	Disch. Temp.	Suc. Press.	Disch. Press.	Disch. Temp.	Suc. Press.	Disch. Press.	Disch. Temp.	Suc. Press.	Disch. Press.	Disch. Temp.	Suc. Press.	Disch. Press.	Disch. Temp.
17	117	131	25	132	142	32	147	153	40	162	164	48	164	177	56	176	192	64	188	208
18	124	129	26	138	140	33	152	151	41	166	162	49	171	174	57	183	188	65	195	201
19	131	127	27	144	138	34	157	149	42	170	160	50	178	171	58	190	183	66	202	195
20	138	125	28	150	136	35	162	147	43	173	158	51	185	169	59	197	179	67	209	189
21	145	123	29	156	134	36	167	145	44	177	156	52	192	166	60	204	174	68	216	183
22	152	121	30	162	132	37	171	143	45	181	154	53	199	163	61	211	170	69	223	177
23	159	119	31	168	130	38	176	141	46	184	152	54	206	160	62	218	165	70	230	171

10 SEER - Refrigerant Charging Tables for Heating Mode of Operation - Continued

2-1/2 Ton

OUTDOOR TEMPERATURE (DEG. F)																				
0			10			20			30			40			50			60		
Suc. Press.	Disch. Press.	Disch. Temp.	Suc. Press.	Disch. Press.	Disch. Temp.	Suc. Press.	Disch. Press.	Disch. Temp.	Suc. Press.	Disch. Press.	Disch. Temp.	Suc. Press.	Disch. Press.	Disch. Temp.	Suc. Press.	Disch. Press.	Disch. Temp.	Suc. Press.	Disch. Press.	Disch. Temp.
15	114	126	23	130	138	30	146	150	38	162	161	46	165	175	53	177	191	61	189	206
16	121	124	24	136	136	31	151	148	39	166	159	47	172	172	54	184	186	62	196	200
17	128	122	25	142	134	32	156	146	40	170	157	48	179	169	55	191	182	63	203	194
18	135	120	26	148	132	33	161	144	41	173	155	49	186	166	56	198	177	64	210	188
19	142	118	27	154	130	34	165	142	42	177	153	50	193	164	57	205	173	65	217	181
20	149	116	28	160	128	35	170	140	43	181	151	51	200	161	58	212	168	66	224	175
21	156	114	29	166	126	36	175	138	44	184	149	52	207	158	59	219	164	67	231	169

3 Ton

OUTDOOR TEMPERATURE (DEG. F)																				
0			10			20			30			40			50			60		
Suc. Press.	Liquid Press.	Disch. Temp.	Suc. Press.	Liquid Press.	Disch. Temp.	Suc. Press.	Liquid Press.	Disch. Temp.	Suc. Press.	Liquid Press.	Disch. Temp.	Suc. Press.	Liquid Press.	Disch. Temp.	Suc. Press.	Liquid Press.	Disch. Temp.	Suc. Press.	Liquid Press.	Disch. Temp.
18	118	149	23	130	148	28	142	148	32	154	148	41	158	160	54	179	183	66	199	207
19	125	147	24	136	146	29	146	146	33	157	146	42	165	157	55	186	179	67	206	201
20	132	145	25	142	144	30	151	144	34	161	144	43	172	154	56	193	174	68	213	195
21	139	143	26	147	142	31	156	142	35	165	142	44	179	151	57	200	170	69	220	188
22	146	141	27	153	140	32	161	140	36	168	140	45	186	148	58	207	165	70	227	182
23	153	139	28	159	138	33	166	138	37	172	138	46	193	145	59	214	161	71	234	176
24	160	137	29	165	136	34	170	136	38	176	136	47	200	143	60	221	156	72	241	170

3-1/2 Ton

OUTDOOR TEMPERATURE (DEG. F)																				
0			10			20			30			40			50			60		
Suc. Press.	Disch. Press.	Disch. Temp.	Suc. Press.	Disch. Press.	Disch. Temp.	Suc. Press.	Disch. Press.	Disch. Temp.	Suc. Press.	Disch. Press.	Disch. Temp.	Suc. Press.	Disch. Press.	Disch. Temp.	Suc. Press.	Disch. Press.	Disch. Temp.	Suc. Press.	Disch. Press.	Disch. Temp.
12	118	142	20	132	144	27	147	146	35	161	149	43	165	167	53	183	200	63	200	234
13	125	140	21	138	142	28	151	144	36	165	147	44	172	164	54	190	196	64	207	227
14	132	138	22	144	140	29	156	142	37	169	145	45	179	161	55	197	191	65	214	221
15	139	136	23	150	138	30	161	140	38	172	143	46	186	158	56	204	187	66	221	215
16	146	134	24	156	136	31	166	138	39	176	141	47	193	155	57	211	182	67	228	209
17	153	132	25	162	134	32	171	136	40	180	139	48	200	153	58	218	178	68	235	203
18	160	130	26	168	132	33	175	134	41	183	137	49	207	150	59	225	173	69	242	197

4 Ton

OUTDOOR TEMPERATURE (DEG. F)																				
0			10			20			30			40			50			60		
Suc. Press.	Disch. Press.	Disch. Temp.	Suc. Press.	Disch. Press.	Disch. Temp.	Suc. Press.	Disch. Press.	Disch. Temp.	Suc. Press.	Disch. Press.	Disch. Temp.	Suc. Press.	Disch. Press.	Disch. Temp.	Suc. Press.	Disch. Press.	Disch. Temp.	Suc. Press.	Disch. Press.	Disch. Temp.
10	125	142	18	141	147	25	157	152	33	173	157	42	176	168	51	189	183	60	203	198
11	132	140	19	147	145	26	162	150	34	177	155	43	183	165	52	196	178	61	210	192
12	139	138	20	153	143	27	167	148	35	181	153	44	190	162	53	203	174	62	217	186
13	146	136	21	159	141	28	172	146	36	184	151	45	197	159	54	210	169	63	224	179
14	153	134	22	165	139	29	176	144	37	188	149	46	204	156	55	217	165	64	231	173
15	160	132	23	171	137	30	181	142	38	192	147	47	211	153	56	224	160	65	238	167
16	167	130	24	177	135	31	186	140	39	195	145	48	218	151	57	231	156	66	245	161

5 Ton

OUTDOOR TEMPERATURE (DEG. F)																				
0			10			20			30			40			50			60		
Suc. Press.	Disch. Press.	Disch. Temp.	Suc. Press.	Disch. Press.	Disch. Temp.	Suc. Press.	Disch. Press.	Disch. Temp.	Suc. Press.	Disch. Press.	Disch. Temp.	Suc. Press.	Disch. Press.	Disch. Temp.	Suc. Press.	Disch. Press.	Disch. Temp.	Suc. Press.	Disch. Press.	Disch. Temp.
15	139	116	19	150	133	23	162	151	27	173	169	36	181	180	50	207	185	64	233	190
16	146	114	20	156	131	24	167	149	28	177	167	37	188	178	51	214	181	65	240	184
17	153	112	21	162	129	25	171	147	29	181	165	38	195	175	52	221	176	66	247	178
18	160	110	22	168	127	26	176	145	30	184	163	39	202	172	53	228	172	67	254	172
19	167	108	23	174	125	27	181	143	31	188	161	40	209	169	54	235	167	68	261	166
20	174	106	24	180	123	28	186	141	32	192	159	41	216	166	55	242	163	69	268	160
21	181	104	25	186	121	29	191	139	33	195	157	42	223	163	56	249	158	70	275	153

* Note: All pressures are listed in psig. and all temperatures in degrees F.



- Shaded Boxes indicate flooded conditions



- Rated Design Values. Suction Pressure will be lower than design value if indoor air flow, entering dry bulb, or entering wet bulb temperatures are lower than design.

- Discharge temperatures greater than charted values indicates a refrigerant undercharge.

12 SEER - Refrigerant Charging Tables for Heating Mode of Operation

2 Ton

OUTDOOR TEMPERATURE (DEG. F)																				
0			10			20			30			40			50			60		
Suc. Press.	Disch. Press.	Disch. Temp.	Suc. Press.	Disch. Press.	Disch. Temp.	Suc. Press.	Disch. Press.	Disch. Temp.	Suc. Press.	Disch. Press.	Disch. Temp.	Suc. Press.	Disch. Press.	Disch. Temp.	Suc. Press.	Disch. Press.	Disch. Temp.	Suc. Press.	Disch. Press.	Disch. Temp.
15	123	130	24	136	131	33	149	132	42	163	133	52	168	139	63	190	151	74	212	163
16	130	128	25	142	129	34	154	130	43	166	131	53	175	136	64	197	146	75	219	156
17	137	126	26	148	127	35	159	128	44	170	129	54	182	133	65	204	142	76	226	150
18	144	124	27	154	125	36	164	126	45	174	127	55	189	130	66	211	137	77	233	144
19	151	122	28	160	123	37	169	124	46	177	125	56	196	128	67	218	133	78	240	138
20	158	120	29	166	121	38	173	122	47	181	123	57	203	125	68	225	128	79	247	132
21	165	118	30	172	119	39	178	120	48	185	121	58	210	122	69	232	124	80	254	126

2-1/2 Ton

OUTDOOR TEMPERATURE (DEG. F)																				
0			10			20			30			40			50			60		
Suc. Press.	Disch. Press.	Disch. Temp.	Suc. Press.	Disch. Press.	Disch. Temp.	Suc. Press.	Disch. Press.	Disch. Temp.	Suc. Press.	Disch. Press.	Disch. Temp.	Suc. Press.	Disch. Press.	Disch. Temp.	Suc. Press.	Disch. Press.	Disch. Temp.	Suc. Press.	Disch. Press.	Disch. Temp.
24	124	134	27	138	139	29	151	145	32	164	150	41	166	164	56	179	185	72	193	207
25	131	132	28	144	137	30	156	143	33	168	148	42	173	161	57	186	181	73	200	201
26	138	130	29	150	135	31	161	141	34	172	146	43	180	158	58	193	176	74	207	194
27	145	128	30	155	133	32	165	139	35	175	144	44	187	155	59	200	172	75	214	188
28	152	126	31	161	131	33	170	137	36	179	142	45	194	152	60	207	167	76	221	182
29	159	124	32	167	129	34	175	135	37	183	140	46	201	150	61	214	163	77	228	176
30	166	122	33	173	127	35	180	133	38	186	138	47	208	147	62	221	158	78	235	170

3 Ton

OUTDOOR TEMPERATURE (DEG. F)																				
0			10			20			30			40			50			60		
Suc. Press.	Disch. Press.	Disch. Temp.	Suc. Press.	Disch. Press.	Disch. Temp.	Suc. Press.	Disch. Press.	Disch. Temp.	Suc. Press.	Disch. Press.	Disch. Temp.	Suc. Press.	Disch. Press.	Disch. Temp.	Suc. Press.	Disch. Press.	Disch. Temp.	Suc. Press.	Disch. Press.	Disch. Temp.
18	130	137	24	141	138	30	152	138	35	163	139	45	168	142	60	193	149	74	217	155
19	137	135	25	147	136	31	156	136	36	166	137	46	175	139	61	200	144	75	224	149
20	144	133	26	153	134	32	161	134	37	170	135	47	182	137	62	207	140	76	231	143
21	151	131	27	158	132	33	166	132	38	174	133	48	189	134	63	214	135	77	238	136
22	158	129	28	164	130	34	171	130	39	177	131	49	196	131	64	221	131	78	245	130
23	165	127	29	170	128	35	176	128	40	181	129	50	203	128	65	228	126	79	252	124
24	172	125	30	176	126	36	180	126	41	185	127	51	210	125	66	235	122	80	259	118

3-1/2 Ton

OUTDOOR TEMPERATURE (DEG. F)																				
0			10			20			30			40			50			60		
Suc. Press.	Disch. Press.	Disch. Temp.	Suc. Press.	Disch. Press.	Disch. Temp.	Suc. Press.	Disch. Press.	Disch. Temp.	Suc. Press.	Disch. Press.	Disch. Temp.	Suc. Press.	Disch. Press.	Disch. Temp.	Suc. Press.	Disch. Press.	Disch. Temp.	Suc. Press.	Disch. Press.	Disch. Temp.
22	136	142	24	143	145	26	149	148	28	156	151	38	161	167	56	187	196	74	213	225
23	143	140	25	149	143	27	154	146	29	160	149	39	168	164	57	194	192	75	220	219
24	150	138	26	155	141	28	159	144	30	163	147	40	175	162	58	201	187	76	227	212
25	157	136	27	160	139	29	164	142	31	167	145	41	182	159	59	208	183	77	234	206
26	164	134	28	166	137	30	168	140	32	171	143	42	189	156	60	215	178	78	241	200
27	171	132	29	172	135	31	173	138	33	174	141	43	196	153	61	222	174	79	248	194
28	178	130	30	178	133	32	178	136	34	178	139	44	203	150	62	229	169	80	255	188

4 Ton

OUTDOOR TEMPERATURE (DEG. F)																				
0			10			20			30			40			50			60		
Suc. Press.	Disch. Press.	Disch. Temp.	Suc. Press.	Disch. Press.	Disch. Temp.	Suc. Press.	Disch. Press.	Disch. Temp.	Suc. Press.	Disch. Press.	Disch. Temp.	Suc. Press.	Disch. Press.	Disch. Temp.	Suc. Press.	Disch. Press.	Disch. Temp.	Suc. Press.	Disch. Press.	Disch. Temp.
21	147	152	24	154	152	26	161	152	28	168	152	39	176	155	58	208	161	78	240	166
22	154	150	25	160	150	27	166	150	29	172	150	40	183	152	59	215	156	79	247	160
23	161	148	26	166	148	28	170	148	30	175	148	41	190	149	60	222	152	80	254	154
24	168	146	27	172	146	29	175	146	31	179	146	42	197	146	61	229	147	81	261	148
25	175	144	28	177	144	30	180	144	32	183	144	43	204	144	62	236	143	82	268	142
26	182	142	29	183	142	31	185	142	33	186	142	44	211	141	63	243	138	83	275	135
27	189	140	30	189	140	32	190	140	34	190	140	45	218	138	64	250	134	84	282	129

* Note: All pressures are listed in psig. and all temperatures in deg. F.

 - Shaded Boxes indicate flooded conditions

 - Rated Design Values. Suction Pressure will be lower than design value if indoor air flow, entering dry bulb, or entering wet bulb temperatures are lower than design.

- Discharge temperatures greater than charted values indicates a refrigerant undercharge.

10 SEER - Refrigerant Charging Tables for Cooling Mode of Operation

2 Ton

	OUTDOOR TEMPERATURE (°F)															
	70		75		80		85		90		95		100		105	
	Suct. Press.	Dis. Press.	Dis. Temp.	Dis. Temp.	Dis. Press.	Dis. Temp.	Dis. Press.	Dis. Temp.	Dis. Press.	Dis. Temp.	Dis. Press.	Dis. Temp.	Dis. Press.	Dis. Temp.	Dis. Press.	Dis. Temp.
70	177	176	162	162												
72		189	166	166												
74	175	189	167	167	202	171										
76	173	189	168	168	203	173	216	177								
78	179	190	170	170	204	174	217	179	230	183						
80		195	175	175	206	177	219	181	232	185	244	189				
82					211	182	222	184	234	188	247	192	259	195		
84							227	188	238	191	249	195	262	199	275	202
86							232	192	242	194	253	197	265	202	278	206
88									246	198	257	200	269	204	281	209
90											261	203	272	206	284	210
92													276	208	287	211
94															290	212
96																

2-1/2 Ton

	OUTDOOR TEMPERATURE (°F)															
	70		75		80		85		90		95		100		105	
	Suct. Press.	Dis. Press.	Dis. Temp.	Dis. Temp.	Dis. Press.	Dis. Temp.	Dis. Press.	Dis. Temp.	Dis. Press.	Dis. Temp.	Dis. Press.	Dis. Temp.	Dis. Press.	Dis. Temp.	Dis. Press.	Dis. Temp.
72	205	163														
74	204	163	216	163												
76	203	163	216	164	229	164										
78	195	158	216	165	229	166	242	167								
80	201	163	212	163	230	167	243	169	256	169						
82		168	218	168	230	168	245	171	258	172	271	172				
84					235	173	247	173	260	174	273	175	286	176		
86							252	177	264	177	276	178	289	179	302	180
88							256	181	268	181	280	181	292	182	305	183
90									272	184	284	184	296	184	309	187
92											288	187	299	186	311	187
94													303	188	314	188
96															317	190
98																

10 SEER - Refrigerant Charging Tables for Cooling Mode of Operation - Continued

3 Ton

		OUTDOOR TEMPERATURE (°F)															
		70		75		80		85		90		95		100		105	
Suct. Press.	Dis. Press.	Dis. Temp.	Dis. Temp.	Dis. Press.	Dis. Temp.	Dis. Press.	Dis. Temp.	Dis. Press.	Dis. Temp.	Dis. Press.	Dis. Temp.	Dis. Press.	Dis. Temp.	Dis. Press.	Dis. Temp.	Dis. Press.	Dis. Temp.
70	213	168															
72	212	168	169														
74	211	168	170	239	172												
76	208	167	171	239	173	174											
78	214	173	172	240	175	176	178										
80			177	242	177	178	180	283	181								
82				247	182	181	182	285	184								
84						185	186	288	187	298	185						
86						189	189	292	189	301	188	314	189				
88							192	295	192	304	191	317	192				
90							195	299	195	308	193	321	196				
92										311	195	323	196				
94										314	197	326	198				
96												329	199				

3-1/2 Ton

		OUTDOOR TEMPERATURE (°F)															
		70		75		80		85		90		95		100		105	
Suct. Press.	Dis. Press.	Dis. Temp.	Dis. Temp.	Dis. Press.	Dis. Temp.	Dis. Press.	Dis. Temp.	Dis. Press.	Dis. Temp.	Dis. Press.	Dis. Temp.	Dis. Press.	Dis. Temp.	Dis. Press.	Dis. Temp.	Dis. Press.	Dis. Temp.
70	208	170															
72	207	171	171														
74	206	171	171	231	172												
76	198	166	172	232	173	174											
78	204	171	171	232	175	176	176										
80			176	232	176	178	179	273	179								
82				238	180	180	181	276	182	288	183						
84						184	184	278	185	291	186	304	186				
86						188	188	282	188	294	189	307	190				
88							191	286	190	298	191	310	193				
90								290	193	301	193	313	193				
92										305	195	316	194				
94												319	196				
96																	

10 SEER - Refrigerant Charging Tables for Cooling Mode of Operation - Continued

4 Ton

		OUTDOOR TEMPERATURE (°F)															
		70		75		80		85		90		95		100		105	
Suct. Press.	Dis. Temp.	Dis. Press.	Dis. Temp.	Dis. Press.	Dis. Temp.	Dis. Press.	Dis. Temp.	Dis. Press.	Dis. Temp.	Dis. Press.	Dis. Temp.	Dis. Press.	Dis. Temp.	Dis. Press.	Dis. Temp.	Dis. Press.	Dis. Temp.
65	187	187	154														
67	186	186	154	199	156												
69	185	185	154	199	157	212	159										
71	176	149	198	158	161	213	161	226	163								
73	182	154	195	156	162	213	162	228	165	241	168						
75			200	161	163	213	163	229	167	243	170	257	173				
77					168	218	168	231	170	245	173	259	176	273	178		
79								236	174	249	176	262	178	276	181	290	184
81								241	178	253	179	266	181	279	184	293	187
83										257	182	270	184	283	186	296	191
85												274	187	286	188	299	191
87														290	190	302	192
89																305	193
91																	

5 Ton

		OUTDOOR TEMPERATURE (°F)															
		70		75		80		85		90		95		100		105	
Suct. Press.	Dis. Temp.	Dis. Press.	Dis. Temp.	Dis. Press.	Dis. Temp.	Dis. Press.	Dis. Temp.	Dis. Press.	Dis. Temp.	Dis. Press.	Dis. Temp.	Dis. Press.	Dis. Temp.	Dis. Press.	Dis. Temp.	Dis. Press.	Dis. Temp.
62	198	198	166														
64	197	197	166	211	167												
66	196	196	166	211	168	226	170										
68	187	160	211	169	171	226	171	241	173								
70	193	166	207	167	173	227	173	242	175	257	177						
72			212	172	174	226	174	244	177	259	179	274	181				
74					178	232	178	246	179	261	182	277	184	292	186		
76								250	183	265	185	279	187	295	189	310	191
78								255	187	269	188	283	190	298	193	313	195
80										273	192	287	193	301	194	316	198
82											195	291	195	305	196	319	198
84														308	198	322	199
86																325	201
88																	

12 SEER - Refrigerant Charging Tables for Cooling Mode of Operation

2 Ton

Suct. Press.		OUTDOOR TEMPERATURE (°F)															
		70		75		80		85		90		95		100		105	
		Dis. Press.	Dis. Temp.	Dis. Press.	Dis. Temp.	Dis. Press.	Dis. Temp.	Dis. Press.	Dis. Temp.	Dis. Press.	Dis. Temp.	Dis. Press.	Dis. Temp.	Dis. Press.	Dis. Temp.	Dis. Press.	Dis. Temp.
73	161	132															
75	160	132	171	132													
77	159	132	171	133	182	134											
79	150	126	171	134	183	135	195	136									
81	156	132	167	132	184	137	196	138	208	138							
83			172	137	183	137	197	140	210	141	222	142					
85					188	142	199	142	212	143	224	145	236	145			
87							204	146	215	146	227	147	239	148	251	149	
89							209	150	220	150	231	150	242	152	254	153	
91									224	153	235	153	246	153	258	156	
93											239	156	249	155	260	156	
95													253	158	263	157	
97															266	159	
99																	

2-1/2 Ton

Suct. Press.		OUTDOOR TEMPERATURE (°F)															
		70		75		80		85		90		95		100		105	
		Dis. Press.	Dis. Temp.	Dis. Press.	Dis. Temp.	Dis. Press.	Dis. Temp.	Dis. Press.	Dis. Temp.	Dis. Press.	Dis. Temp.	Dis. Press.	Dis. Temp.	Dis. Press.	Dis. Temp.	Dis. Press.	Dis. Temp.
72	172	143															
74	171	143	184	144													
76	170	143	184	145	197	146											
78	163	139	184	146	197	148	210	149									
80	169	145	181	145	198	149	212	151	225	153	240	156					
82			186	150	198	151	213	153	227	155	242	159	255	161			
84					203	155	215	156	229	158	245	162	258	164	271	165	
86							220	160	232	161	249	165	261	167	274	168	
88							225	164	236	164	252	168	265	169	278	172	
90									241	167	256	170	268	171	280	172	
92											271	173	283	173	286	175	
94																	
96																	
98																	

12 SEER - Refrigerant Charging Tables for Cooling Mode of Operation - Continued

3 Ton

Suct. Press.	OUTDOOR TEMPERATURE (°F)																
	70		75		80		85		90		95		100		105		
	Dis. Press.	Dis. Temp.	Dis. Press.	Dis. Temp.	Dis. Press.	Dis. Temp.	Dis. Press.	Dis. Temp.	Dis. Press.	Dis. Temp.	Dis. Press.	Dis. Temp.	Dis. Press.	Dis. Temp.	Dis. Press.	Dis. Temp.	
69	164	145															
71	163	145	176	145													
73	162	145	176	146	189	146											
75	155	141	176	147	190	147	203	148									
77	161	147	173	146	190	149	204	150	217	150							
79			179	151	191	150	205	152	219	152	233	152					
81					196	155	208	154	221	155	235	155	248	155			
83							213	158	225	158	238	158	251	159	264	159	
85							218	162	229	161	241	161	254	162	268	162	
87									234	165	245	164	258	164	271	166	
89											249	167	261	166	274	166	
91													265	168	276	167	
93															279	169	
95																	

3-1/2 Ton

Suct. Press.	OUTDOOR TEMPERATURE (°F)																
	70		75		80		85		90		95		100		105		
	Dis. Press.	Dis. Temp.	Dis. Press.	Dis. Temp.	Dis. Press.	Dis. Temp.	Dis. Press.	Dis. Temp.	Dis. Press.	Dis. Temp.	Dis. Press.	Dis. Temp.	Dis. Press.	Dis. Temp.	Dis. Press.	Dis. Temp.	
69	178	148															
71	176	148	189	149													
73	175	148	188	150	201	151											
75	163	140	188	151	202	153	215	154									
77	169	146	182	147	203	154	216	156	230	158							
79			188	153	201	154	218	158	232	161	245	162					
81					206	159	219	160	234	163	248	165	261	167			
83							224	164	237	166	250	168	264	171	278	173	
85							229	168	241	169	254	171	267	174	281	176	
87									246	173	258	174	271	175	285	180	
89											262	177	274	177	287	179	
91													278	180	290	180	
93															293	182	
95																	

12 SEER - Refrigerant Charging Tables for Cooling Mode of Operation - Continued

4 Ton

Suct. Press.	OUTDOOR TEMPERATURE (°F)																
	70		75		80		85		90		95		100		105		
	Dis. Press.	Dis. Temp.	Dis. Press.	Dis. Temp.	Dis. Press.	Dis. Temp.	Dis. Press.	Dis. Temp.	Dis. Press.	Dis. Temp.	Dis. Press.	Dis. Temp.	Dis. Press.	Dis. Temp.	Dis. Press.	Dis. Temp.	
66	180	154															
68	179	154		155													
70	178	154		156	158												
72	171	150	193	157	159	208	222	161									
74	178	156	190	156	161	208	223	163	238	165							
76			196	162	167	209	225	165	240	167	254	169					
78						214	227	168	242	169	257	171	271	173			
80							232	172	245	173	259	174	274	176	288	178	
82							237	176	250	176	263	177	277	179	291	181	
84									254	179	267	180	280	181	295	185	
86											271	183	284	183	297	185	
88													287	185	300	186	
90															303	188	
92																	

* Note: All pressures are listed in psig. and all temperatures in °F.



- Shaded Boxes indicate flooded conditions



- Rated Design Values. Suction Pressure will be lower than design value if indoor air flow, entering dry bulb, or entering wet bulb temperatures are lower than design.

- Discharge temperatures greater than charted values indicate an undercharged system.

INSTALLER

**PLEASE LEAVE THESE
INSTALLATION INSTRUCTIONS
WITH THE HOMEOWNER.**



7082990

7082990 (Replaces 708109B)

Specifications and illustrations subject to change without
notice and without incurring obligations. (0903)