

Single Package Heat Pump

Installation Instructions

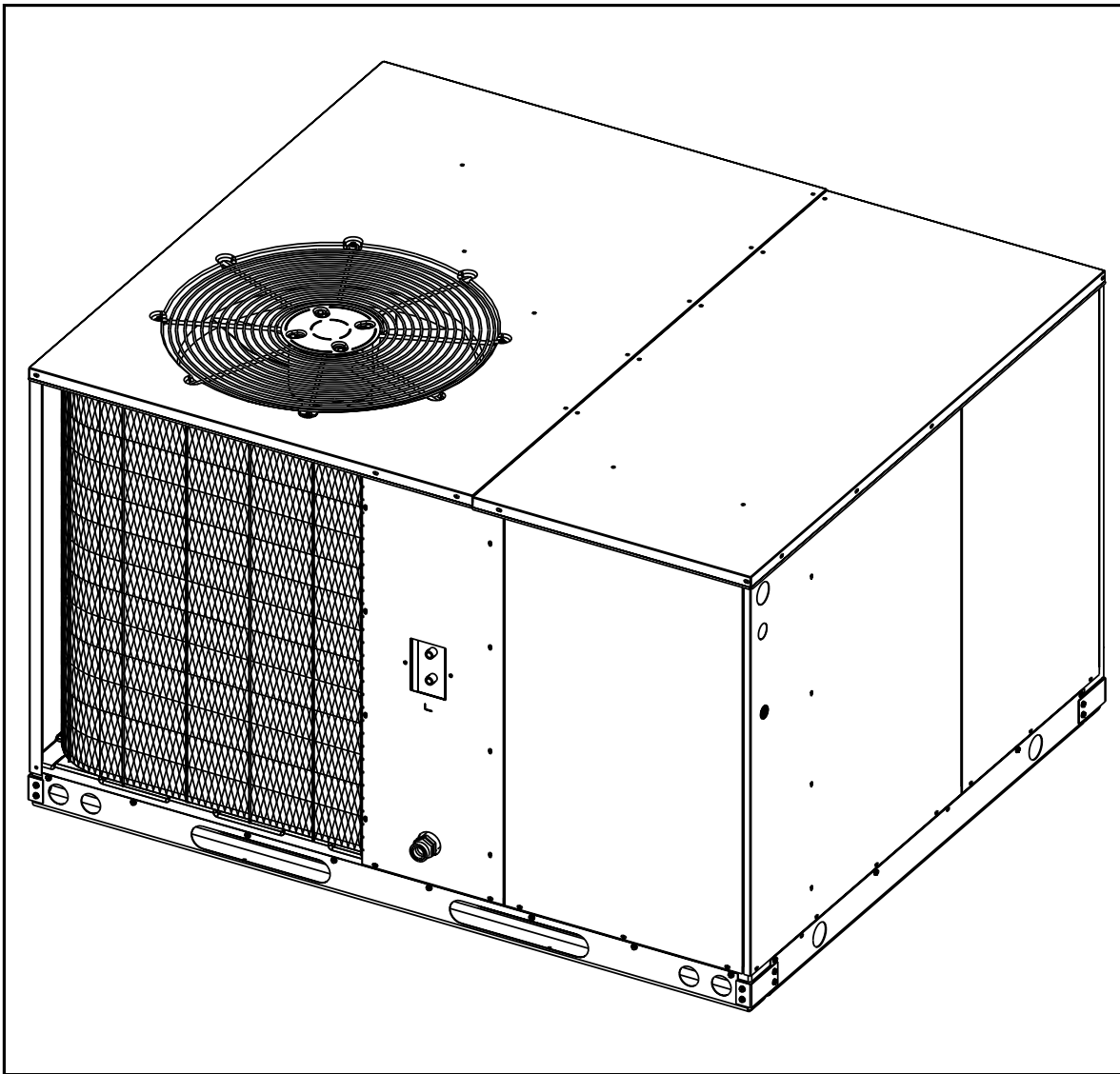

IMPORTANT

These instructions are primarily intended to assist qualified individuals experienced in the proper installation of heating and/or air conditioning appliances. Some local codes require licensed installation/service personnel for this type equipment. All installations must be in accordance with these instructions and with all applicable national and local codes and standards.

Read these instructions thoroughly before starting the installation. Follow all precautions and warnings contained within these instructions and on the unit.

SECTION 1. OWNER INFORMATION

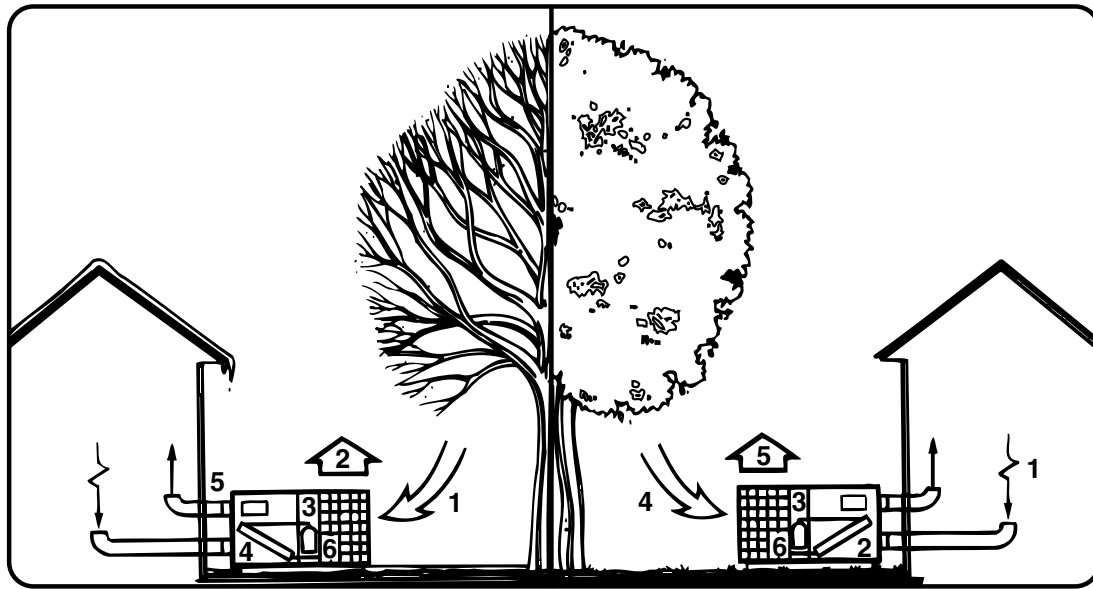

WINTER HEATING

SUMMER COOLING

1. Outdoor air enters the heat pump.
 2. The cold, heat-transfer section (outdoor coil) extracts the heat from the air as the refrigerant evaporates from a liquid to a cold gas.
 3. The refrigerant, compressed to a hot gas by the heat pump, carries the heat to the heat-transfer section (indoor coil).
 4. The hot, heat-transfer section (indoor coil) releases the heat as the refrigerant condenses from a gas to a liquid.
 5. The blower circulates the heat throughout the home via the supply duct.
 6. The refrigerant returns to the outdoor coil and evaporates once again to absorb more heat.
1. Indoor air enters the return air duct.
 2. The cold, heat-transfer section (indoor coil) extracts the heat from the air as the refrigerant evaporates from a liquid to a cold gas.
 3. The refrigerant, drawn to the heat pump and compressed to a hot gas, carries the heat outdoors.
 4. The hot, heat-transfer section (outdoor coil) releases the heat as the refrigerant condenses from a gas to a liquid.
 5. The heat pump (outdoor fan) discharges the heat to the outside air.
 6. The refrigerant returns to the indoor coil and evaporates once again to absorb more heat.

It is the sole responsibility of the homeowner to make certain that heat pump has been correctly set up and adjusted to operate properly.

The Manufacturer warrants the heat pump to be free from defects in material or workmanship for a period of one year. We will not be responsible for any costs found necessary to correct problems due to improper setup, improper installation, adjustments, improper operating procedure on the part of the user, etc.

Some specific examples of service calls which are not included in the limited warranty are:

1. Correcting wiring problems in the electrical circuit supplying the heat pump.
2. Resetting circuit breakers or other switches.

3. Adjusting or calibrating of thermostat.

To avoid misunderstandings at a later date, carefully review these responsibilities with your dealer or service company.

The heat pump system will heat and cool your home and save your energy dollars.

During the summer, a heat pump cools a house by absorbing heat from within the house and exhausting it outdoors. During the winter, a heat pump heats a house by absorbing heat outdoors and exhausting it indoors. This is an efficient heating means because you pay for "moving" heat from outdoors to indoors, but do not pay to generate the heat.

OPERATING INSTRUCTIONS

To Operate Your Heat Pump For Cooling —

1. Set the thermostat system switch to COOL and the thermostat fan switch to AUTO. See Figure 1.
2. Set the thermostat temperature selector to the desired cooling temperature. The outdoor unit fan, the indoor blower, and the compressor will all cycle on and off to maintain the indoor temperature at the desired cooling level.

NOTE: If the thermostat temperature level is re-adjusted, or if the thermostat system switch is re-positioned, the outdoor unit fan and the compressor may not start immediately. A protective timer circuit holds the compressor and the outdoor fan off for approximately six minutes following a previous operation or the interruption of the main electric power

To Operate Your Heat Pump For Heating —

1. Set the thermostat system switch for HEAT and the thermostat fan switch to AUTO. See Figure 1.
2. Set the thermostat temperature selector to the desired heating temperature. The outdoor unit fan, the indoor blower, and the compressor will all cycle on and off to maintain the indoor temperature at the desired heating level.

NOTE: If the thermostat temperature level is re-adjusted, or if the thermostat system switch is re-positioned, the outdoor unit fan and the compressor may not start immediately. A protective timer circuit holds the compressor and the outdoor fan off for approximately six minutes following a previous operation or the interruption of the main electrical power.

Emergency Heat — Some thermostats will include a system switch position termed EM HT or AUX HT, etc. This is a back-up heating mode to be used only if there is a suspected problem. With the system switch set to EM HT, etc., the compressor and outdoor fan will be locked off and supplemental heat (electric resistance heating) will be used as a source of heat. Sustained use of electric resistance heat in place of the heat pump will result in an increase in electric utility costs.

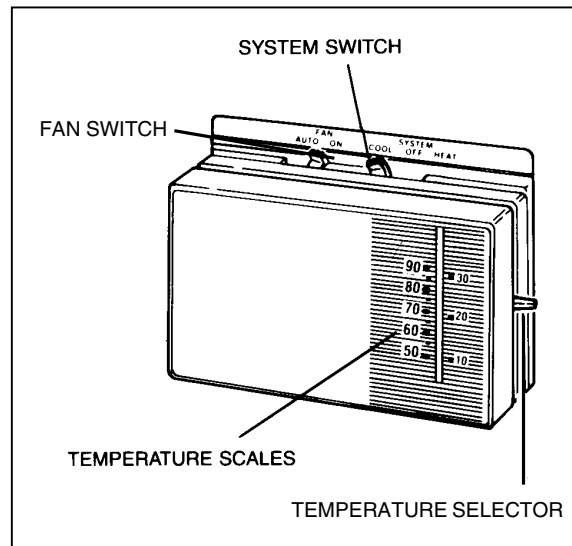

Figure 1. Typical Thermostat

Defrost — During cold weather heating operation, the outdoor unit will develop a coating of snow and ice on the heat transfer coil. This is normal and the unit will periodically defrost itself. During the defrost cycle, the outdoor fan will stop, while the compressor continues to run and heat the outdoor coil, causing the snow and ice to melt. During defrost, there may be some steam rise from the outdoor unit as the warm coil causes some melted frost to evaporate.

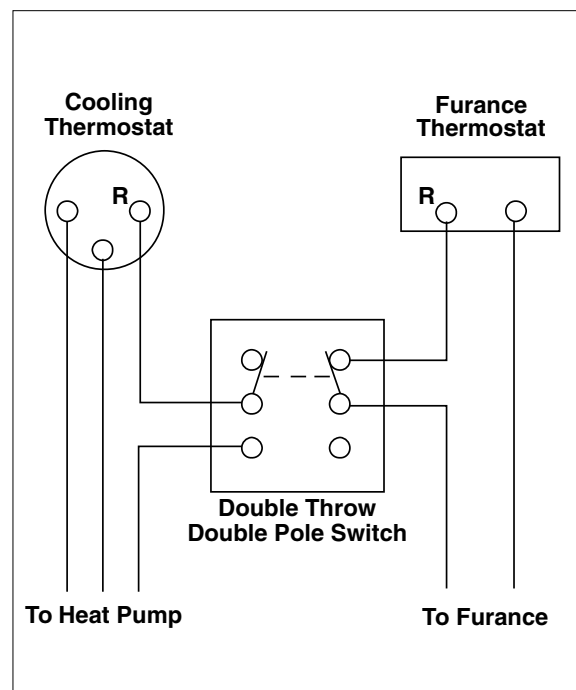

Figure 2. Thermostat Interlock System

SPECIFICATIONS

Single Package Heat Pumps are designed for outdoor rooftop or ground level slab installations. The units are shipped ready for horizontal duct connections and are easily converted for down flow applications.

All models are shipped from the factory with the following:

1. Zero clearance to combustibles
2. Multi-speed direct-drive blower.
3. Compressor Anti-short-cycle timer for single phase models.
4. Blower Speed Relay.
5. Horizontal or Down flow duct connections.

The unit dimensions are shown in **Figure 3**.

Optional field-installed electric heater kits are available in 5 kw through 20 kw heating capacities. A separate installation instruction document for the electric heaters and their application accompanies this one. A two stage heat 24VAC thermostat should be used with electric heater kits installed.

SAFETY CONSIDERATIONS

It is the responsibility of the installer to ensure that the installation is made in accordance with all applicable local and national codes.

WARNING:

Improper installation, service, adjustment, or maintenance may cause explosion, fire, electrical shock or other hazardous conditions which may result in personal injury or property damage. Unless otherwise noted in these instructions, only factory authorized kits or accessories may be used with this product. Noncompliance may void the unit's warranty.

Labels, Tags — When working with this equipment, follow all precautions in the literature, on tags, and on labels provided with the unit and/or approved field installed kits. The type of hazard and severity are described on each label or tag.

Pressures Within The System — This equipment contains liquid and gaseous refrigerant under high pressure. Installation or servicing should only be performed by qualified trained personnel thoroughly familiar with this type equipment.

INSTALLATION REQUIREMENTS

Equipment Check — Before beginning the installation, verify that the unit model is correct for the job. The unit model number is printed on the data label. All units have been securely packaged at the point of shipment. After unpacking the unit, carefully inspect it for apparent and concealed damage. Claims for damage should be filed with the carrier by the consignee.

Requirements and Codes — The installer must comply with all local codes and regulations which govern this type equipment. Local codes and regulations take precedence over any recommendations contained in these instructions. All electrical wiring must be made in accordance with local codes and regulations and with the National Electric Code (ANSI/NFPA 70) or in Canada the Canadian Electric Code Part 1 CSA C.22.1. Air Ducts must be installed in accordance with the standards of the National Fire Protection Association “Standards for Installation of Air Conditioning and Ventilation Systems” (NFPA 90A), “Standard for Installation of Residence Type Warm Air Heating and Air Conditioning Systems” (NFPA 90B), these instructions and all applicable local codes.

NFPA publications are available by writing:

National Fire Protection Association
Batterymarch Park
Quincy, Maine 02269

Unit Location — This heat pump is designed only for outdoor installations. Choosing the location of the unit should be based on minimizing the length of the supply and return ducts. Consideration should also be given to availability of electric power, service access, noise, and shade. Sufficient clearance for unobstructed airflow through the outdoor coil must be maintained in order to achieve rated performance **See Figure 4** for minimum clearances to obstructions.

Air Filters — A suitable air filter must be installed in the return air system. Air filter pressure drop must not exceed 0.08 inches w.c. at 300 fpm.

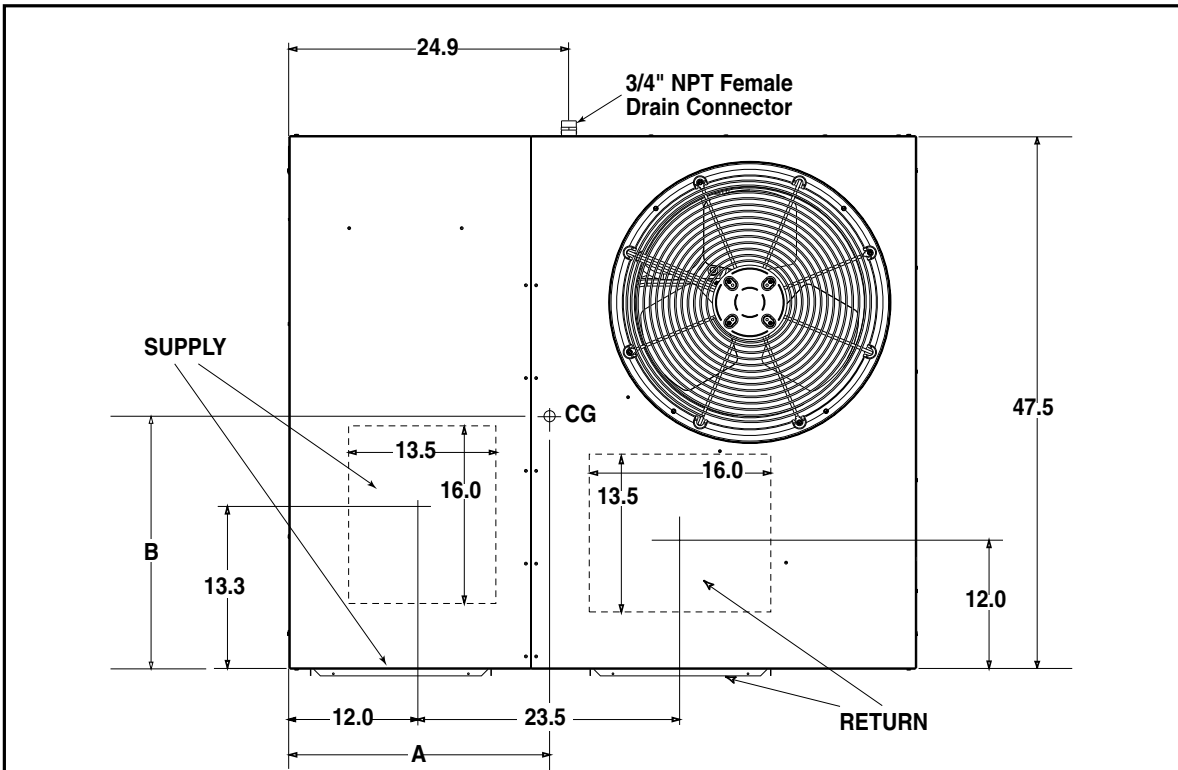

Top View

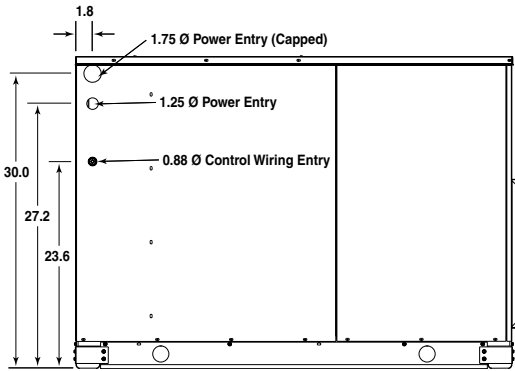

Side View

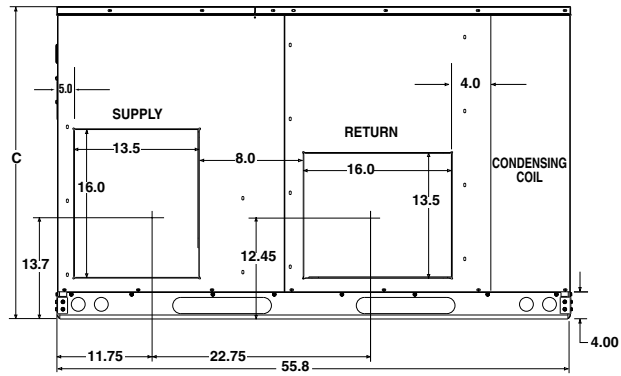

Back View

| Model No. | Unit Weight | Center of Gravity | | Height (in inches) | |
|---------------|-------------|-------------------|------|--------------------|--------------------|
| | | A | B | C | |
| | | | | with base rails | without base rails |
| 3 Ton 10 SEER | 420 | 28.0 | 26.0 | 35.0 | 31.3 |
| 4 Ton 10 SEER | 510 | 28.0 | 26.0 | 35.0 | 31.3 |
| 5 Ton 10 SEER | 540 | 29.5 | 26.5 | 39.0 | 35.3 |
| 3 Ton 12 SEER | 455 | 28.0 | 25.5 | 35.0 | 31.3 |
| 4 Ton 12 SEER | 565 | 29.5 | 26.0 | 39.0 | 35.3 |
| 5 Ton 12 SEER | 575 | 29.5 | 26.0 | 39.0 | 35.3 |

Figure 3. Dimensions

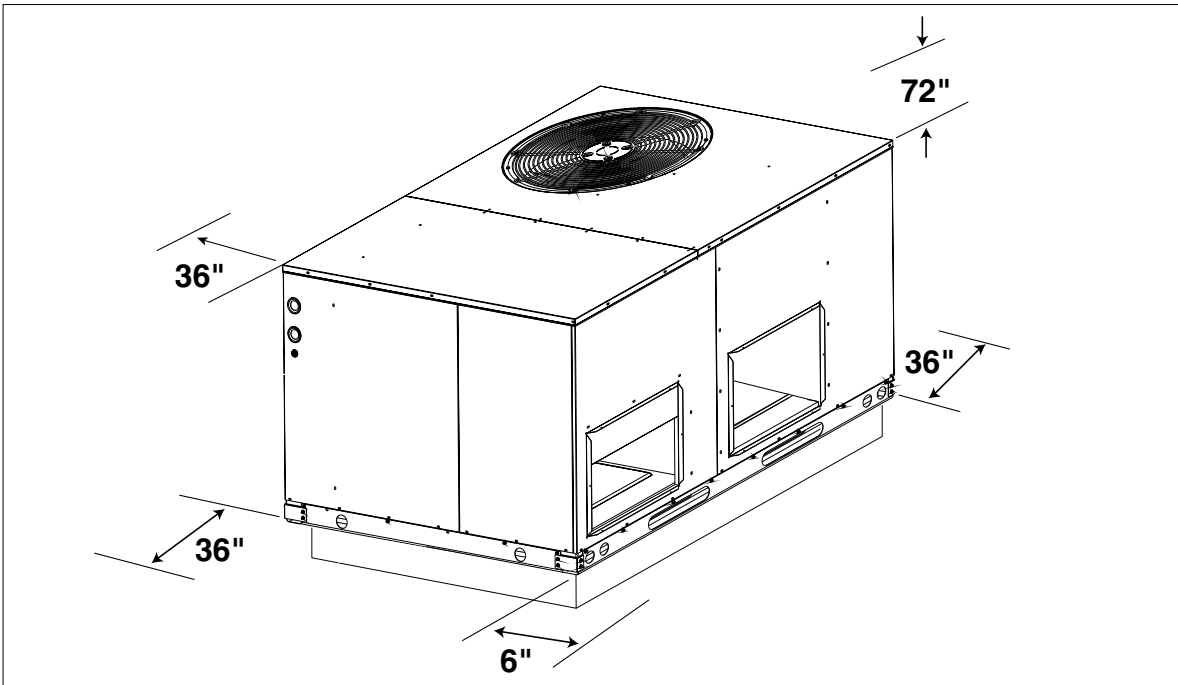

Figure 4. Minimum Clearances

Condensate Drain — Condensate is removed from the unit through the 3/4" female pipe fitting located on the front side of the unit. **See Figure 5.** Install a 2 inch condensate trap in the drain line of the same size and prime with water. When connecting rigid drain line, hold the female fitting with a wrench to prevent twisting. **Do not over tighten!** Refer to local codes and restrictions for proper condensate disposal requirements.

UNIT INSTALLATION

Ground Level — When installing the unit at ground level, provide a concrete mounting pad separate from the building foundation. The pad must be level to insure proper condensate disposal and strong enough to support the unit's

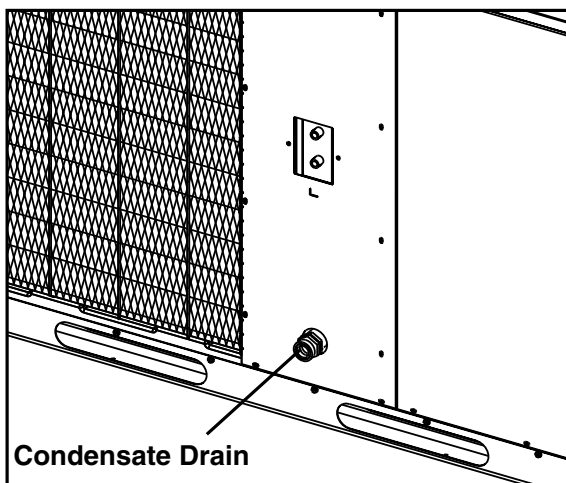

Figure 5. Condensate Drain

weight. Refer to **Figure 3.** Make sure the slab is a minimum of 2" above the grade and in an area that drains well. **See Figure 6.**

Rigging and Hoisting — The unit should be lifted using slings and spreader bars. The spreader bars are necessary to prevent damaging the top of the unit's cabinet. Make sure that the lifting equipment is adequate for the load. Refer to **Figure 3** for unit weights. Keep the unit in an upright position at all times. **For rooftop installations, remove and discard the two supports attached beneath the unit.**

! WARNING:

To avoid the risk of property damage or personal injury; it is the rigger's responsibility to insure that whatever means are used to hoist the unit are safe and adequate.

! CAUTION:

All panels must be securely in place when rigging and hoisting.

The rigging must be located outside the unit's center of gravity. Refer to **Figure 3** for center of gravity locations.

Rooftop — For rooftop installations use the appropriate accessory roof curb and follow all instructions included with it. Make sure the two supports beneath the unit have been removed. Locate the unit according to local building codes and ordinances. The curb must be level to insure proper condensate drainage. **See Figure 7.**

The roof must be capable of handling the weight of the unit. **See Figure 3** for unit weights. Reinforce the roof if required.

AIR DUCTS

This unit is designed only for use with a supply and return duct. Air ducts should be installed in accordance with the standards of the National Fire Protection Association “Standard for Installation of Air Conditioning Systems” (NFPA 90A), “Standard for Installation of Residence Type Warm Air Heating and Air Conditioning Systems” (NFPA 90B), and all applicable local codes.

Design the duct work according to methods described by the National Warm Air Heating and Air Conditioning Association (ACCA). The ducts must be properly sized not to exceed .2" w.c. pressure drop at 400 scfm per nominal ton of cooling capacity.

Duct work should be attached directly to the unit flanges for horizontal applications. On roof curb installations the ducts must be attached to the curb hangers, not the unit.

Unconditioned Spaces — All duct work passing through unconditioned space must be properly insulated to minimize duct losses and prevent

condensation. Use insulation with an outer vapor barrier. Refer to local codes for insulation material requirements.

Acoustical Duct Work — Certain installations may require the use of acoustical lining inside the supply duct work. Acoustical insulation must be in accordance with the current revision of the Sheet Metal and Air Conditioning Contractors National Association (SMACNA) application standard for duct liners. Duct lining must be UL classified batts or blankets with a fire hazard classification of FHC-25/50 or less. Fiber duct work may be used in place of internal duct liners if the fiber duct work is in accordance with the current revision of the SMACNA construction standard on fibrous glass ducts. Fibrous duct work and internal acoustical lining must be NFPA Class 1 air ducts when tested per UL Standard 181 for Class 1 ducts.

Horizontal to Down flow Conversion — The unit is shipped ready for horizontal duct connections. If down flow ducts are required, the unit must be converted following the steps below for both the supply and return ducts.

- 1) Locate the duct cap inside the duct openings and remove the screw holding it in place.
- 2) Lift the cap out of the unit. (The cap can be pushed up from the bottom by reaching through the fork slot).
- 3) Cover the horizontal duct opening with the cap. The insulation will be on the indoor side.
- 4) Fasten the cover with screws and seal to prevent air leakage.

Clearance — These units are approved for 0 inch clearance.

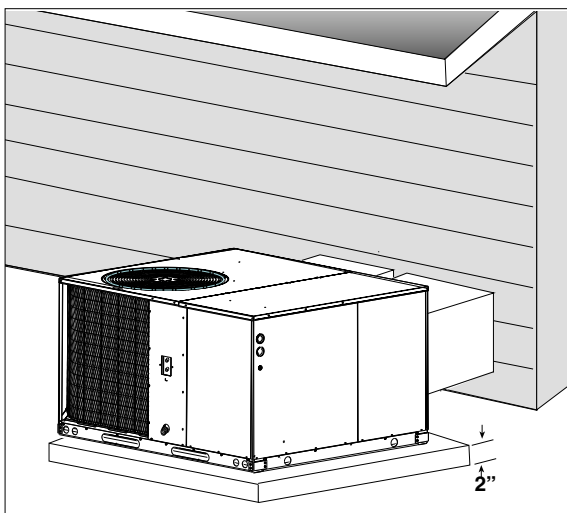

Figure 6. Ground Level Installation

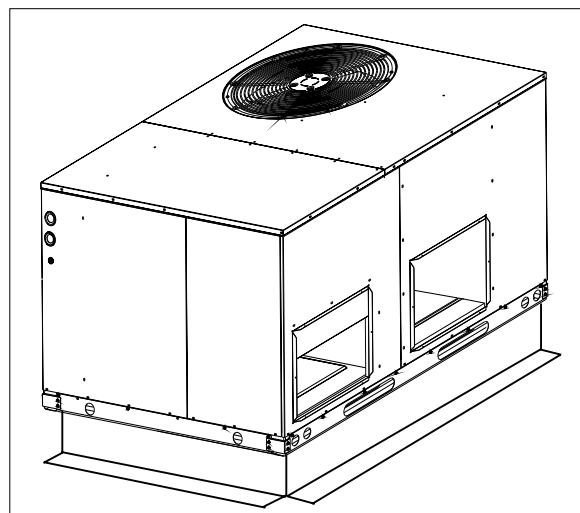

Figure 7. Roof Top Installation

ELECTRICAL WIRING

General — Electrical power wiring must be made in accordance with all applicable local codes and ordinances, and with the current revision of the National Electric Code NFPA 70 or in Canada CSA C.22.1 - Canadian Electrical Code Part 1. If any of the original wire as supplied with the unit must be replaced, it must be replaced with material of the same gage and temperature rating.



WARNING:

To avoid the risk of electrical shock, personal injury, or death, disconnect all electrical power to the unit before performing any maintenance or service. The unit may have more than one electrical power supply.

Line Voltage — Before proceeding with the electrical connections, make certain that the voltage, frequency, and phase of the supply source are the same as those specified on the unit rating plate. Also verify that the service provided by the utility is sufficient to handle the additional load imposed by this equipment.

See the unit wiring label for proper high and low voltage wiring. Make all electrical connections in accordance with all applicable codes and ordinances.

Use a separate branch electrical circuit for this unit. A means of electrical disconnect must be located within sight of and readily accessibility to the unit. Internally mounted circuit breakers are available as field installed options. These circuit breakers can be used as an electrical disconnect.

The unit is shipped from the factory wired for 240 volt transformer operation. For 208 volt operation, remove the lead from the transformer terminal marked 240V and connect it to the terminal marked 208V. For maximum ampacity and over current protection, see the unit rating plate.

Provide power supply (or supplies) for the unit in accordance with the unit wiring diagram, and the unit rating plate. Connect the line-voltage leads to the corresponding terminals on the contactor (or the circuit breaker when the field installed circuit breaker kits are used) inside the control compartment. Use only copper wire for the line

voltage power supply to this unit. Use proper code agency listed conduit and a conduit connector for connecting the supply wires to the unit and for obtaining proper grounding. Grounding may also be accomplished by using the grounding lug provided in the control box.



WARNING:

The unit cabinet must have and uninterrupted or unbroken electrical ground to minimize personal injury if an electrical fault should occur. This ground may consist of electrical wire or approved conduit when installed in accordance with existing national or local codes.

Blower Speed — The blower speed is preset at the factory for operation at the same speed for heating and cooling. For optimum system performance and comfort, it may be necessary to change the factory set speed. To change the blower speed:

1. Disconnect all electrical power to the unit and remove the service panel.
2. Remove the motor lead from terminal #4 of the blower relay. Cut the wire tie holding the motor lead bundle. The motor leads are color coded as shown in **Figure 9**.
3. If the desired heating blower speed is different than the cooling speed, remove and discard the jumper wire between terminals #6 and #4. on the blower relay. Place the desired heating blower speed lead on terminal #6 and the desired cooling blower speed lead on terminal #4 of the blower relay. Use another wire tie (field supplied) to bundle the remaining motor leads.



CAUTION:

To avoid personal injury or property damage, make certain that the motor leads cannot come into contact with any uninsulated metal components of the unit.

Check all factory wiring per the unit wiring diagram and inspect the factory wiring connections to be sure none loosened during shipping or installation.

Low Voltage Connections

Room Thermostat — Several options are available for a room thermostat depending on the accessories installed with the unit. Select a thermostat which operates in conjunction with the installed accessories. The thermostat should be mounted about five feet above the ground on an inside wall. The thermostat should be kept away from drafts, slamming doors, lamps, direct sunlight, or in line with the supply air flow.

To install the thermostat:

1. Position the sub base on an inside wall and mark the mounting holes and thermostat cable openings.
2. Cut out the cable opening and route the thermostat cable from the unit's low voltage compartment to the thermostat location. The thermostat cable is supplied by the installer.
3. Connect the cable leads to the sub base or thermostat terminals and to the unit's low voltage pigtails as shown in **Figure 10**. A system wiring diagram is also provided on the inside of the control panel cover.
4. Secure sub base or thermostat to the wall using screws provided with the thermostat.
5. If sub base is used, install the correct thermostat housing to sub base.
6. Refer to thermostat instruction sheet for complete detailed mounting information.

Defrost Cycle Timer — The defrost cycle timer controls the time interval of the hot gas defrost after the defrost sensor closes. It is located in the lower left corner of the defrost control board on the low voltage side of the control box. Three interval settings are available: 30 minutes, 60 minutes, and 90 minutes. Time setting selection is dependent on the climate where the unit is being installed.

Example 1. Dry climate of Southern Arizona. A 90 minute setting is recommended.

Example 2. Moist climate of Seattle, Washington. A 30 minute setting is recommended.

To set the cycle timer, place the timing pin on the defrost control board to the desired time interval post.

Note: All units are shipped from the factory with the default time setting of 30 minutes.

Field Installed Electric Heat — These Single Package Heat Pumps are designed to allow optional electric heat to be field installed as required by the building's particular heating load. The options available for each unit are shown in the heater kit installation instructions. As noted in the instructions, a field installed circuit breaker kit is available as a means of electrical disconnect for the unit.

Install the heater kits as directed by the installation instructions that come as part of the heater kit. Follow all cautions and warnings as directed.

START UP AND SYSTEM CHECK

Pre-Start Check List

- Verify that the unit is level to allow proper condensate drainage.
- Verify that there is free airflow to and from the outdoor coil and that all clearance requirements are met.
- Verify that the duct work is sealed to prevent air leakage.
- Verify that the line voltage power leads are securely connected and the unit is properly grounded.
- Verify that the low voltage wires are securely connected to the correct leads on the low voltage terminal strip.
- Verify that all exterior panels are replaced and securely fastened.
- Verify that the outdoor fan turns freely.
- Verify that the power supply branch circuit overcurrent protection is sized properly.
- Verify that the thermostat is wired correctly. The thermostat function switch should be set to "Off" and the thermostat fan switch should be set to "Auto."

Start-Up Procedure

Close all electrical disconnects to energize the system.

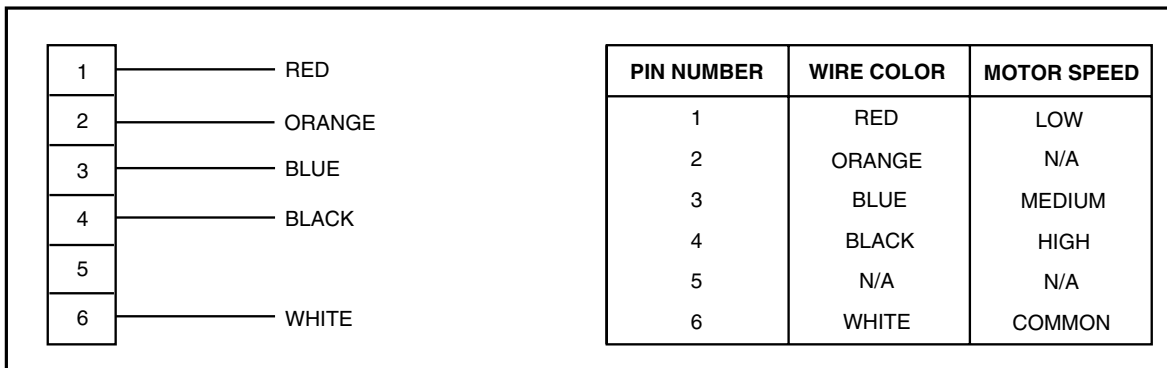

Figure 9. Motor Lead Connector

WARNING:

If the unit is equipped with a crankcase heater, allow 24 hours prior to continuing the start up procedures to allow for heating of the refrigerant compressor crankcase. Failure to comply may result in damage and could cause premature failure of the system. This warning should be followed at initial start up and any time the power has been removed for 12 hours or longer.

Air Circulation — Leave the thermostat system switch set to “Off” and set the thermostat fan switch to “On.” The blower motor should run continuously. Check for air delivery at the register(s). Ensure that there are no obstructions at the registers or in the duct work. Set thermostat fan switch to “Auto.”

Short Cycle Protection — With the system operating in cooling mode, note the temperature setting of the thermostat and gradually raise the set-point temperature until the unit de-energizes. Immediately lower the set point temperature of the thermostat to its original setting and verify that the indoor blower is energized. Verify that after approximately 5 minutes the compressor and fan energize and that the temperature of the discharge air is cooler than the room temperature. This is available only for the single phase models.

System Cooling

1. Set the thermostat system switch to “Cool” and the thermostat fan switch to “Auto”. Gradually lower the thermostat temperature switch below room temperature and observe that the blower, compressor, and fan energize. Check that

air cooler than room temperature is being discharged at the register. Listen for any unusual noises.

2. After allowing the unit to run for several minutes, set the temperature selector above room temperature.
 - The fan and compressor cycles off with the thermostat.
 - The blower should also stop unless fan switch is set to “ON” position.

System Heating — If the unit has been equipped with optional electric heater kits, set the system thermostat switch to HEAT and set the thermostat fan switch to AUTO. Verify that the compressor and outdoor fan are not energized but that the blower and heaters are. Check for warm air at the supply registers.

UNIT MAINTENANCE

WARNING:

To avoid risk of electrical shock, personal injury, or death, disconnect all electrical power to the unit before performing any maintenance or service. The unit may have more than one electrical supply.

Refrigerant Charging — Packaged heat pumps are fully charged at the factory. The system refrigerant charge can be checked and adjusted through the service ports provided in the front panel. Use only gauge lines which have a “Schrader” depression device present to actuate the valve. Draw a vacuum on gauge lines to remove air before attaching them to the service ports on the unit. Refrigerant charging must be done by qualified personnel familiar with safe and environmentally responsible refrigerant handling procedures.

WARNING:

Single Packaged Heat Pumps are shipped fully charged and ready for installation. When a system is installed according to these instructions, no refrigerant charging is required. If repairs make it necessary for evacuation and charging, it should only be done by qualified, trained personnel thoroughly familiar with this equipment. Some local codes require licensed installation/service personnel to service this type of equipment. Under no circumstances should the owner attempt to install and/or service this equipment. Failure to comply with this warning could result in property damage, personal injury, or death.

perform maintenance on this equipment requires certain mechanical skills and tools. If you do not possess these skills, contact your dealer for maintenance. Consult your local dealer about the availability of maintenance contracts. At a minimum, routine maintenance should include the following:

1. Inspect and clean or replace air filters at the beginning of each heating and cooling season, or more frequently if required.
2. Inspect the condensate drain and outdoor coil at the beginning of each cooling season. Remove any debris. Clean the outdoor coil and louvers as necessary using a mild detergent and water. Rinse thoroughly with water.
3. Inspect the electrical connections for tightness at the beginning of each heating and cooling season. Service as necessary.

CAUTION:

Use care when removing parts from this unit. Personal injury can result from sharp metal edges present in all equipment of sheet metal construction.

CAUTION:

The unit should never be operated without a filter in the return air system. Replace disposable filters with the same type and size.

Routine Maintenance — Proper maintenance is important to achieve optimum performance from the heat pump. The ability to properly

| Model | Speed | External Static Pressure Drop - inches water column | | | | | | | |
|-----------------------------|--------|---|------|------|------|------|------|------|------|
| | | 0.1 | 0.2 | 0.3 | 0.4 | 0.5 | 0.6 | 0.7 | 0.8 |
| 2.5 Ton 3 Ton 10 SEER | High | 1600 | 1510 | 1410 | 1310 | 1200 | 1070 | 930 | 760 |
| | Medium | 1410 | 1330 | 1250 | 1150 | 1050 | 940 | 820 | 670 |
| | Low | 1130 | 1070 | 1000 | 930 | 850 | 760 | 650 | 530 |
| 3.5 Ton 4 Ton 10 SEER | High | 2200 | 2140 | 2070 | 2000 | 1930 | 1850 | 1770 | 1690 |
| | Medium | 1940 | 1890 | 1830 | 1760 | 1700 | 1630 | 1560 | 1490 |
| | Low | 1560 | 1510 | 1460 | 1410 | 1360 | 1310 | 1250 | 1200 |
| 5 Ton 10 SEER | High | 2200 | 2140 | 2070 | 2000 | 1930 | 1850 | 1770 | 1690 |
| | Medium | 1940 | 1890 | 1830 | 1760 | 1700 | 1630 | 1560 | 1490 |
| | Low | 1560 | 1510 | 1460 | 1410 | 1360 | 1310 | 1250 | 1200 |
| 3 Ton 12 SEER | High | 1600 | 1510 | 1410 | 1310 | 1200 | 1070 | 930 | 760 |
| | Medium | 1410 | 1330 | 1250 | 1150 | 1050 | 940 | 820 | 670 |
| | Low | 1130 | 1070 | 1000 | 930 | 850 | 760 | 650 | 530 |
| 4 Ton 12 SEER | High | 2270 | 2200 | 2140 | 2070 | 2000 | 1930 | 1850 | 1770 |
| | Medium | 2000 | 1940 | 1890 | 1830 | 1760 | 1700 | 1630 | 1560 |
| | Low | 1600 | 1560 | 1510 | 1460 | 1410 | 1360 | 1310 | 1250 |
| 5 Ton 12 SEER | High | 2270 | 2200 | 2140 | 2070 | 2000 | 1930 | 1850 | 1770 |
| | Medium | 2000 | 1940 | 1890 | 1830 | 1760 | 1700 | 1630 | 1560 |
| | Low | 1600 | 1560 | 1510 | 1460 | 1410 | 1360 | 1310 | 1250 |

Table 1. Blower Curves

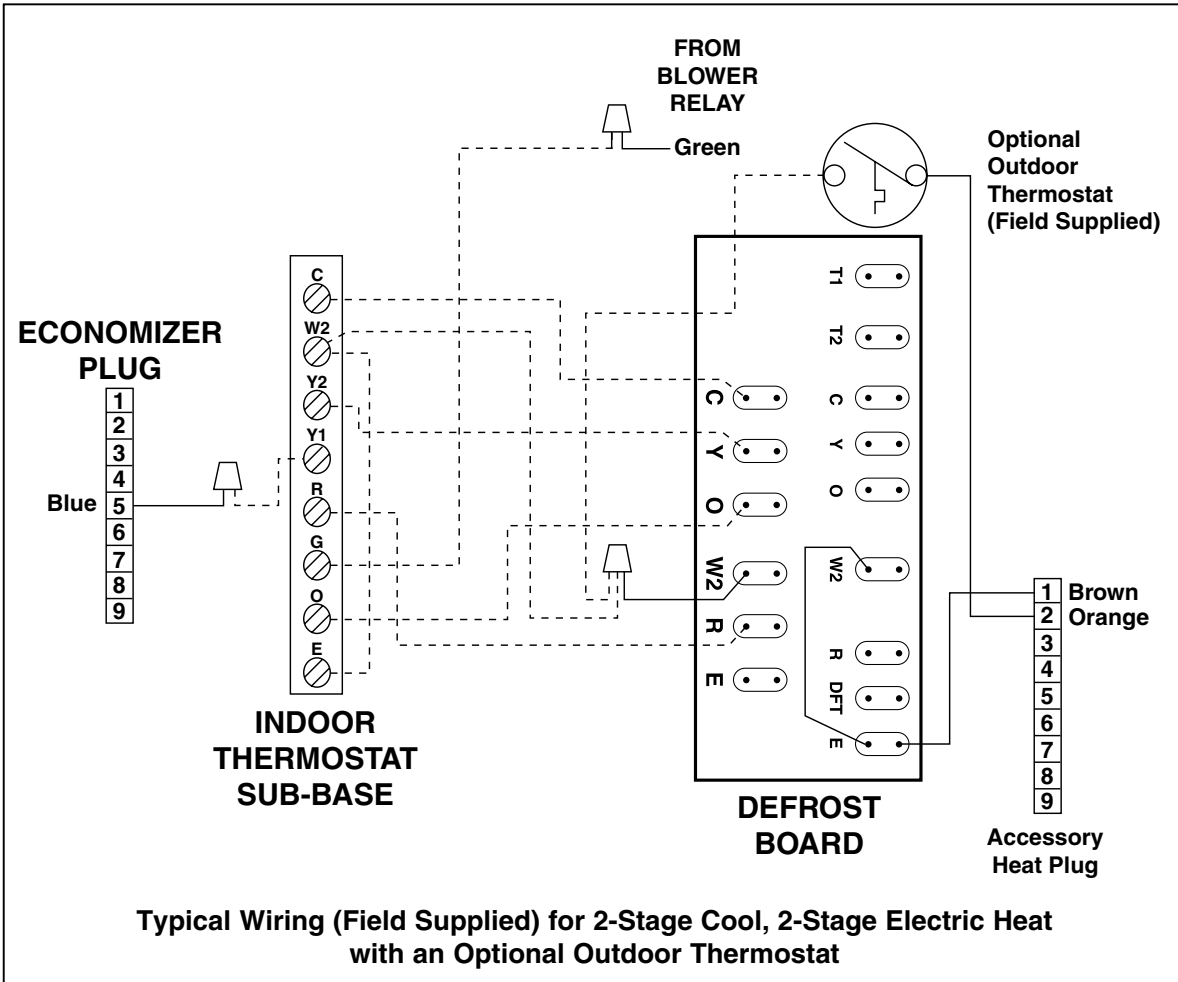
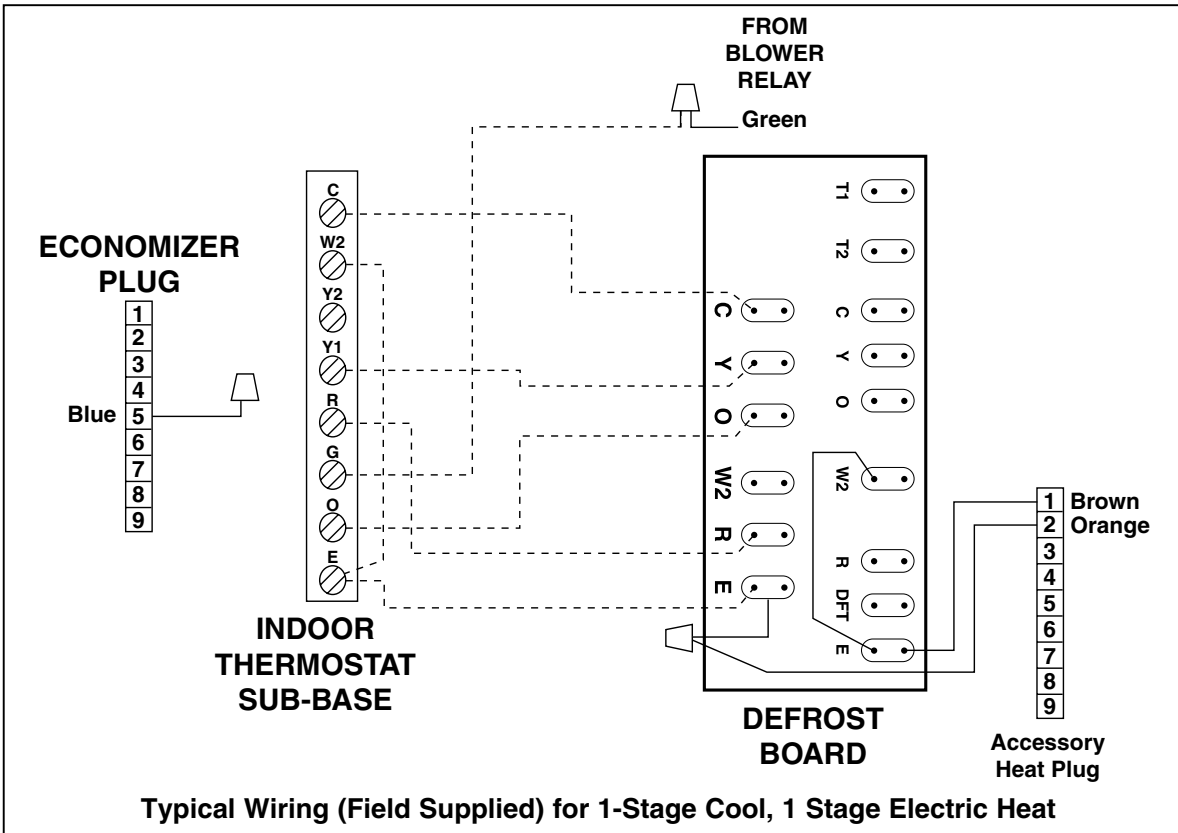

Figure 10. Typical Heat Pump Thermostat Connections

Heat Pump in Heating

2.5 TON

| OUTDOOR TEMPERATURE (° F) | | | | | | | | | | | | | | | | | | | | |
|---------------------------|--------------|---------------|-------------|--------------|---------------|-------------|--------------|---------------|-------------|--------------|---------------|-------------|--------------|---------------|-------------|--------------|---------------|-------------|--------------|---------------|
| 0 | | | 10 | | | 20 | | | 30 | | | 40 | | | 50 | | | 60 | | |
| Suc. Press. | Disch. Temp. | Disch. Press. | Suc. Press. | Disch. Temp. | Disch. Press. | Suc. Press. | Disch. Temp. | Disch. Press. | Suc. Press. | Disch. Temp. | Disch. Press. | Suc. Press. | Disch. Temp. | Disch. Press. | Suc. Press. | Disch. Temp. | Disch. Press. | Suc. Press. | Disch. Temp. | Disch. Press. |
| 16 | 115 | 118 | 22 | 129 | 128 | 29 | 143 | 137 | 36 | 157 | 147 | 45 | 161 | 161 | 55 | 177 | 180 | 65 | 193 | 200 |
| 17 | 122 | 116 | 23 | 135 | 126 | 30 | 148 | 135 | 37 | 161 | 145 | 46 | 168 | 158 | 56 | 184 | 176 | 66 | 200 | 193 |
| 18 | 129 | 114 | 24 | 141 | 124 | 31 | 153 | 133 | 38 | 165 | 143 | 47 | 175 | 155 | 57 | 191 | 171 | 67 | 207 | 187 |
| 19 | 136 | 112 | 25 | 147 | 122 | 32 | 157 | 131 | 39 | 168 | 141 | 48 | 182 | 153 | 58 | 198 | 167 | 68 | 214 | 181 |
| 20 | 143 | 110 | 26 | 153 | 120 | 33 | 162 | 129 | 40 | 172 | 139 | 49 | 189 | 150 | 59 | 205 | 162 | 69 | 221 | 175 |
| 21 | 150 | 108 | 27 | 158 | 118 | 34 | 167 | 127 | 41 | 176 | 137 | 50 | 196 | 147 | 60 | 212 | 158 | 70 | 228 | 169 |
| 22 | 157 | 106 | 28 | 164 | 116 | 35 | 172 | 125 | 42 | 179 | 135 | 51 | 203 | 144 | 61 | 219 | 153 | 71 | 235 | 163 |

3 TON

| OUTDOOR TEMPERATURE (° F) | | | | | | | | | | | | | | | | | | | | |
|---------------------------|--------------|---------------|-------------|--------------|---------------|-------------|--------------|---------------|-------------|--------------|---------------|-------------|--------------|---------------|-------------|--------------|---------------|-------------|--------------|---------------|
| 0 | | | 10 | | | 20 | | | 30 | | | 40 | | | 50 | | | 60 | | |
| Suc. Press. | Disch. Temp. | Disch. Press. | Suc. Press. | Disch. Temp. | Disch. Press. | Suc. Press. | Disch. Temp. | Disch. Press. | Suc. Press. | Disch. Temp. | Disch. Press. | Suc. Press. | Disch. Temp. | Disch. Press. | Suc. Press. | Disch. Temp. | Disch. Press. | Suc. Press. | Disch. Temp. | Disch. Press. |
| 17 | 123 | 138 | 22 | 135 | 138 | 27 | 146 | 138 | 32 | 158 | 137 | 41 | 164 | 149 | 54 | 190 | 171 | 67 | 215 | 194 |
| 18 | 130 | 136 | 23 | 141 | 136 | 28 | 151 | 136 | 33 | 161 | 135 | 42 | 171 | 146 | 55 | 197 | 167 | 68 | 222 | 187 |
| 19 | 137 | 134 | 24 | 147 | 134 | 29 | 156 | 134 | 34 | 165 | 133 | 43 | 178 | 143 | 56 | 204 | 162 | 69 | 229 | 181 |
| 20 | 144 | 132 | 25 | 152 | 132 | 30 | 161 | 132 | 35 | 169 | 131 | 44 | 185 | 140 | 57 | 211 | 158 | 70 | 236 | 175 |
| 21 | 151 | 130 | 26 | 158 | 130 | 31 | 165 | 130 | 36 | 172 | 129 | 45 | 192 | 137 | 58 | 218 | 153 | 71 | 243 | 169 |
| 22 | 158 | 128 | 27 | 164 | 128 | 32 | 170 | 128 | 37 | 176 | 127 | 46 | 199 | 134 | 59 | 225 | 149 | 72 | 250 | 163 |
| 23 | 165 | 126 | 28 | 170 | 126 | 33 | 175 | 126 | 38 | 180 | 125 | 47 | 206 | 132 | 60 | 232 | 144 | 73 | 257 | 157 |

Table 2. 10 SEER Heating Charging Charts

Heat Pump in Heating

3.5 TON

| OUTDOOR TEMPERATURE (° F) | | | | | | | | | | | | | | | | | | | |
|---------------------------|--------------|-------------|--------------|-------------|--------------|-------------|--------------|-------------|--------------|-------------|--------------|-------------|--------------|-------------|-----|-----|----|-----|-----|
| Suc. Press. | 0 | | 10 | | 20 | | 30 | | 40 | | 50 | | 60 | | | | | | |
| | Disch. Temp. | Suc. Press. | Disch. Temp. | Suc. Press. | Disch. Temp. | Suc. Press. | Disch. Temp. | Suc. Press. | Disch. Temp. | Suc. Press. | Disch. Temp. | Suc. Press. | Disch. Temp. | Suc. Press. | | | | | |
| 13 | 125 | 19 | 141 | 123 | 24 | 157 | 131 | 30 | 173 | 138 | 39 | 180 | 159 | 52 | 199 | 195 | 65 | 219 | 231 |
| 14 | 132 | 20 | 147 | 121 | 25 | 162 | 129 | 31 | 177 | 136 | 40 | 187 | 157 | 53 | 206 | 191 | 66 | 226 | 225 |
| 15 | 139 | 21 | 153 | 119 | 26 | 167 | 127 | 32 | 181 | 134 | 41 | 194 | 154 | 54 | 213 | 186 | 67 | 233 | 219 |
| 16 | 146 | 22 | 159 | 117 | 27 | 172 | 125 | 33 | 185 | 132 | 42 | 201 | 151 | 55 | 220 | 182 | 68 | 240 | 212 |
| 17 | 153 | 23 | 164 | 115 | 28 | 176 | 123 | 34 | 188 | 130 | 43 | 208 | 148 | 56 | 227 | 177 | 69 | 247 | 206 |
| 18 | 160 | 24 | 170 | 113 | 29 | 181 | 121 | 35 | 192 | 128 | 44 | 215 | 145 | 57 | 234 | 173 | 70 | 254 | 200 |
| 19 | 167 | 25 | 176 | 111 | 30 | 186 | 119 | 36 | 196 | 126 | 45 | 222 | 142 | 58 | 241 | 168 | 71 | 261 | 194 |

4 TON

| OUTDOOR TEMPERATURE (° F) | | | | | | | | | | | | | | | | | | | |
|---------------------------|--------------|-------------|--------------|-------------|--------------|-------------|--------------|-------------|--------------|-------------|--------------|-------------|--------------|-------------|-----|-----|----|-----|-----|
| Suc. Press. | 0 | | 10 | | 20 | | 30 | | 40 | | 50 | | 60 | | | | | | |
| | Disch. Temp. | Suc. Press. | Disch. Temp. | Suc. Press. | Disch. Temp. | Suc. Press. | Disch. Temp. | Suc. Press. | Disch. Temp. | Suc. Press. | Disch. Temp. | Suc. Press. | Disch. Temp. | Suc. Press. | | | | | |
| 14 | 129 | 20 | 143 | 135 | 25 | 158 | 135 | 31 | 172 | 136 | 39 | 178 | 141 | 51 | 200 | 152 | 62 | 222 | 162 |
| 15 | 136 | 21 | 149 | 133 | 26 | 162 | 133 | 32 | 175 | 134 | 40 | 185 | 138 | 52 | 207 | 147 | 63 | 229 | 156 |
| 16 | 143 | 22 | 155 | 131 | 27 | 167 | 131 | 33 | 179 | 132 | 41 | 192 | 136 | 53 | 214 | 143 | 64 | 236 | 150 |
| 17 | 150 | 23 | 161 | 129 | 28 | 172 | 129 | 34 | 183 | 130 | 42 | 199 | 133 | 54 | 221 | 138 | 65 | 243 | 144 |
| 18 | 157 | 24 | 167 | 127 | 29 | 177 | 127 | 35 | 186 | 128 | 43 | 206 | 130 | 55 | 228 | 134 | 66 | 250 | 137 |
| 19 | 164 | 25 | 173 | 125 | 30 | 181 | 125 | 36 | 190 | 126 | 44 | 213 | 127 | 56 | 235 | 129 | 67 | 257 | 131 |
| 20 | 171 | 26 | 179 | 123 | 31 | 186 | 123 | 37 | 194 | 124 | 45 | 220 | 124 | 57 | 242 | 125 | 68 | 264 | 125 |

* Note: All pressures are listed in psig. and all temperatures in deg. F.

— Shaded Boxes indicate flooded conditions

— Rated Design Values. Suction Pressure will be lower than design value if indoor air flow, entering dry bulb, or entering wet bulb temperatures are lower than design.

— Discharge temperatures greater than charted values indicates a refrigerant undercharge.

Table 2a. 10 SEER Heating Charging Charts

Heat Pump in Heating

5 TON

| | | OUTDOOR TEMPERATURE (° F) | | | | | | | | | | | | | | | | | | | | |
|-------------|--------------|---------------------------|--------------|-------------|--------------|-------------|--------------|-------------|--------------|-------------|--------------|-------------|--------------|-------------|--------------|-------------|--------------|-------------|--------------|-------------|--------------|--|
| | | 0 | | | 10 | | | 20 | | | 30 | | | 40 | | | 50 | | | 60 | | |
| Suc. Press. | Disch. Temp. | Suc. Press. | Disch. Temp. | Suc. Press. | Disch. Temp. | Suc. Press. | Disch. Temp. | Suc. Press. | Disch. Temp. | Suc. Press. | Disch. Temp. | Suc. Press. | Disch. Temp. | Suc. Press. | Disch. Temp. | Suc. Press. | Disch. Temp. | Suc. Press. | Disch. Temp. | Suc. Press. | Disch. Temp. | |
| 12 | 122 | 126 | 139 | 127 | 127 | 26 | 156 | 127 | 172 | 128 | 41 | 179 | 135 | 148 | 51 | 199 | 148 | 61 | 220 | 161 | | |
| 13 | 129 | 124 | 20 | 145 | 125 | 27 | 160 | 125 | 176 | 126 | 42 | 186 | 132 | 143 | 52 | 206 | 143 | 62 | 227 | 155 | | |
| 14 | 136 | 122 | 21 | 151 | 123 | 28 | 165 | 123 | 180 | 124 | 43 | 193 | 129 | 139 | 53 | 213 | 139 | 63 | 234 | 149 | | |
| 15 | 143 | 120 | 22 | 156 | 121 | 29 | 170 | 121 | 183 | 122 | 44 | 200 | 126 | 134 | 54 | 220 | 134 | 64 | 241 | 143 | | |
| 16 | 150 | 118 | 23 | 162 | 119 | 30 | 175 | 119 | 187 | 120 | 45 | 207 | 123 | 130 | 55 | 227 | 130 | 65 | 248 | 136 | | |
| 17 | 157 | 116 | 24 | 168 | 117 | 31 | 179 | 117 | 191 | 118 | 46 | 214 | 120 | 125 | 56 | 234 | 125 | 66 | 255 | 130 | | |
| 18 | 164 | 114 | 25 | 174 | 115 | 32 | 184 | 115 | 194 | 116 | 47 | 221 | 118 | 121 | 57 | 241 | 121 | 67 | 262 | 124 | | |

* Note: All pressures are listed in psig. and all temperatures in deg. F.

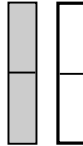

— Shaded Boxes indicate flooded conditions



— Rated Design Values. Suction Pressure will be lower than design value if indoor air flow, entering dry bulb, or entering wet bulb temperatures are lower than design.

— Discharge temperatures greater than charted values indicates a refrigerant undercharge.

Table 2b. 10 SEER Heating Charging Charts

Heat Pump in Heating

3 TON

| OUTDOOR TEMPERATURE (° F) | | | | | | | | | | | | | | | | | | | | |
|-----------------------------|--------------|-------------|--------------|-------------|--------------|-------------|--------------|-------------|--------------|-------------|--------------|-------------|--------------|-------------|--------------|-------------|--------------|-------------|--------------|-----|
| 0 | | 10 | | | 20 | | | 30 | | | 40 | | | 50 | | | 60 | | | |
| Suc. Press. | Disch. Temp. | Suc. Press. | Disch. Temp. | Suc. Press. | Disch. Temp. | Suc. Press. | Disch. Temp. | Suc. Press. | Disch. Temp. | Suc. Press. | Disch. Temp. | Suc. Press. | Disch. Temp. | Suc. Press. | Disch. Temp. | Suc. Press. | Disch. Temp. | Suc. Press. | Disch. Temp. | |
| 17 | 125 | 127 | 22 | 135 | 127 | 27 | 146 | 128 | 32 | 157 | 128 | 41 | 161 | 143 | 54 | 182 | 172 | 68 | 203 | 202 |
| 18 | 132 | 125 | 23 | 141 | 125 | 28 | 151 | 126 | 33 | 161 | 126 | 42 | 168 | 140 | 55 | 189 | 168 | 69 | 210 | 196 |
| 19 | 139 | 123 | 24 | 147 | 123 | 29 | 156 | 124 | 34 | 164 | 124 | 43 | 175 | 137 | 56 | 196 | 163 | 70 | 217 | 189 |
| 20 | 146 | 121 | 25 | 153 | 121 | 30 | 160 | 122 | 35 | 168 | 122 | 44 | 182 | 134 | 57 | 203 | 159 | 71 | 224 | 183 |
| 21 | 153 | 119 | 26 | 159 | 119 | 31 | 165 | 120 | 36 | 172 | 120 | 45 | 189 | 131 | 58 | 210 | 154 | 72 | 231 | 177 |
| 22 | 160 | 117 | 27 | 165 | 117 | 32 | 170 | 118 | 37 | 175 | 118 | 46 | 196 | 129 | 59 | 217 | 150 | 73 | 238 | 171 |
| 23 | 167 | 115 | 28 | 171 | 115 | 33 | 175 | 116 | 38 | 179 | 116 | 47 | 203 | 126 | 60 | 224 | 145 | 74 | 245 | 165 |

4 TON

| OUTDOOR TEMPERATURE (° F) | | | | | | | | | | | | | | | | | | | | |
|-----------------------------|--------------|-------------|--------------|-------------|--------------|-------------|--------------|-------------|--------------|-------------|--------------|-------------|--------------|-------------|--------------|-------------|--------------|-------------|--------------|-----|
| 0 | | 10 | | | 20 | | | 30 | | | 40 | | | 50 | | | 60 | | | |
| Suc. Press. | Disch. Temp. | Suc. Press. | Disch. Temp. | Suc. Press. | Disch. Temp. | Suc. Press. | Disch. Temp. | Suc. Press. | Disch. Temp. | Suc. Press. | Disch. Temp. | Suc. Press. | Disch. Temp. | Suc. Press. | Disch. Temp. | Suc. Press. | Disch. Temp. | Suc. Press. | Disch. Temp. | |
| 14 | 119 | 124 | 20 | 137 | 124 | 26 | 154 | 124 | 33 | 171 | 125 | 42 | 182 | 138 | 55 | 210 | 165 | 68 | 239 | 191 |
| 15 | 126 | 122 | 21 | 143 | 122 | 27 | 159 | 122 | 34 | 175 | 123 | 43 | 189 | 135 | 56 | 217 | 160 | 69 | 246 | 185 |
| 16 | 133 | 120 | 22 | 148 | 120 | 28 | 163 | 120 | 35 | 178 | 121 | 44 | 196 | 133 | 57 | 224 | 156 | 70 | 253 | 179 |
| 17 | 140 | 118 | 23 | 154 | 118 | 29 | 168 | 118 | 36 | 182 | 119 | 45 | 203 | 130 | 58 | 231 | 151 | 71 | 260 | 173 |
| 18 | 147 | 116 | 24 | 160 | 116 | 30 | 173 | 116 | 37 | 186 | 117 | 46 | 210 | 127 | 59 | 238 | 147 | 72 | 267 | 166 |
| 19 | 154 | 114 | 25 | 166 | 114 | 31 | 178 | 114 | 38 | 189 | 115 | 47 | 217 | 124 | 60 | 245 | 142 | 73 | 274 | 160 |
| 20 | 161 | 112 | 26 | 172 | 112 | 32 | 183 | 112 | 39 | 193 | 113 | 48 | 224 | 121 | 61 | 252 | 138 | 74 | 281 | 154 |

* Note: All pressures are listed in psig, and all temperatures in deg. F.

Shaded Boxes indicate flooded conditions

Rated Design Values. Suction Pressure will be lower than design value if indoor air flow, entering dry bulb, or entering wet bulb temperatures are lower than design.

Discharge temperatures greater than charted values indicates a refrigerant undercharge.

Table 3. 12 SEER Heating Charging Charts

Heat Pump in Heating

5 TON

| | | OUTDOOR TEMPERATURE (° F) | | | | | | | | | | | | | | | | | | | |
|-------------|--------------|----------------------------|--------------|-------------|--------------|-------------|--------------|-------------|--------------|-------------|--------------|-------------|--------------|-------------|--------------|-------------|--------------|-------------|--------------|-------------|--------------|
| | | 0 | | | 10 | | | 20 | | | 30 | | | 40 | | | 50 | | | 60 | |
| Suc. Press. | Disch. Temp. | Suc. Press. | Disch. Temp. | Suc. Press. | Disch. Temp. | Suc. Press. | Disch. Temp. | Suc. Press. | Disch. Temp. | Suc. Press. | Disch. Temp. | Suc. Press. | Disch. Temp. | Suc. Press. | Disch. Temp. | Suc. Press. | Disch. Temp. | Suc. Press. | Disch. Temp. | Suc. Press. | Disch. Temp. |
| 9 | 121 | 120 | 17 | 137 | 121 | 25 | 153 | 122 | 33 | 168 | 122 | 42 | 176 | 129 | 52 | 198 | 143 | 62 | 220 | 156 | |
| 10 | 128 | 118 | 18 | 143 | 119 | 26 | 157 | 120 | 34 | 172 | 120 | 43 | 183 | 127 | 53 | 205 | 138 | 63 | 227 | 149 | |
| 11 | 135 | 116 | 19 | 149 | 117 | 27 | 162 | 118 | 35 | 176 | 118 | 44 | 190 | 124 | 54 | 212 | 134 | 64 | 234 | 143 | |
| 12 | 142 | 114 | 20 | 155 | 115 | 28 | 167 | 116 | 36 | 179 | 116 | 45 | 197 | 121 | 55 | 219 | 129 | 65 | 241 | 137 | |
| 13 | 149 | 112 | 21 | 161 | 113 | 29 | 172 | 114 | 37 | 183 | 114 | 46 | 204 | 118 | 56 | 226 | 125 | 66 | 248 | 131 | |
| 14 | 156 | 110 | 22 | 166 | 111 | 30 | 177 | 112 | 38 | 187 | 112 | 47 | 211 | 115 | 57 | 233 | 120 | 67 | 255 | 125 | |
| 15 | 163 | 108 | 23 | 172 | 109 | 31 | 181 | 110 | 39 | 190 | 110 | 48 | 218 | 112 | 58 | 240 | 116 | 68 | 262 | 119 | |

* Note: All pressures are listed in psig. and all temperatures in deg. F.

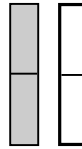

— Shaded Boxes indicate flooded conditions

— Rated Design Values. Suction Pressure will be lower than design value if indoor air flow, entering dry bulb, or entering wet bulb temperatures are lower than design.

— Discharge temperatures greater than charted values indicates a refrigerant undercharge.

Table 3a. 12 SEER Heating Charging Charts

Heat Pump in Cooling

2.5 TON

| | | OUTDOOR TEMPERATURE (° F) | | | | | | | | | | | | | | | |
|-------------|--------------|-----------------------------|--------------|--------------|--------------|--------------|--------------|--------------|--------------|--------------|--------------|--------------|--------------|--------------|--------------|--------------|--------------|
| | | 70 | | 75 | | 80 | | 85 | | 90 | | 95 | | 100 | | 105 | |
| Suct. Pres. | Disch. Temp. | Disch. Pres. | Disch. Temp. | Disch. Pres. | Disch. Temp. | Disch. Pres. | Disch. Temp. | Disch. Pres. | Disch. Temp. | Disch. Pres. | Disch. Temp. | Disch. Pres. | Disch. Temp. | Disch. Pres. | Disch. Temp. | Disch. Pres. | Disch. Temp. |
| 72 | 167 | 154 | | | | | | | | | | | | | | | |
| 74 | 169 | 160 | 183 | 158 | | | | | | | | | | | | | |
| 76 | 172 | 165 | 185 | 163 | 199 | 162 | | | | | | | | | | | |
| 78 | 175 | 168 | 187 | 168 | 201 | 167 | 214 | 166 | | | | | | | | | |
| 80 | 178 | 171 | 191 | 172 | 203 | 172 | 217 | 170 | 230 | 169 | | | | | | | |
| 82 | | | 194 | 175 | 206 | 175 | 219 | 175 | 232 | 174 | 246 | 173 | | | | | |
| 84 | | | | | 210 | 179 | 222 | 179 | 234 | 178 | 248 | 177 | 262 | 177 | | | |
| 86 | | | | | | | 225 | 182 | 238 | 182 | 250 | 181 | 264 | 181 | 277 | 180 | |
| 88 | | | | | | | 229 | 186 | 241 | 186 | 253 | 185 | 266 | 185 | 279 | 184 | |
| 90 | | | | | | | | | 245 | 190 | 257 | 190 | 269 | 189 | 281 | 188 | |
| 92 | | | | | | | | | | | 260 | 194 | 273 | 193 | 285 | 192 | |
| 94 | | | | | | | | | | | | | 276 | 197 | 288 | 197 | |
| 96 | | | | | | | | | | | | | | | 292 | 201 | |
| 98 | | | | | | | | | | | | | | | | | |

3 TON

| | | OUTDOOR TEMPERATURE (° F) | | | | | | | | | | | | | | | |
|-------------|--------------|-----------------------------|--------------|--------------|--------------|--------------|--------------|--------------|--------------|--------------|--------------|--------------|--------------|--------------|--------------|--------------|--------------|
| | | 70 | | 75 | | 80 | | 85 | | 90 | | 95 | | 100 | | 105 | |
| Suct. Pres. | Disch. Temp. | Disch. Pres. | Disch. Temp. | Disch. Pres. | Disch. Temp. | Disch. Pres. | Disch. Temp. | Disch. Pres. | Disch. Temp. | Disch. Pres. | Disch. Temp. | Disch. Pres. | Disch. Temp. | Disch. Pres. | Disch. Temp. | Disch. Pres. | Disch. Temp. |
| 72 | 189 | 153 | | | | | | | | | | | | | | | |
| 74 | 190 | 167 | 204 | 158 | | | | | | | | | | | | | |
| 76 | 190 | 184 | 205 | 170 | 219 | 158 | 230 | 155 | 242 | 156 | | | | | | | |
| 78 | 191 | 201 | 206 | 184 | 221 | 172 | 234 | 160 | 245 | 164 | 256 | 160 | | | | | |
| 80 | 192 | 218 | 208 | 198 | 222 | 185 | 236 | 172 | 249 | 170 | 260 | 166 | 271 | 163 | | | |
| 82 | | | 209 | 213 | 224 | 198 | 238 | 187 | 252 | 178 | 265 | 171 | 275 | 169 | 286 | 167 | |
| 84 | | | | | 226 | 210 | 240 | 198 | 254 | 189 | 267 | 181 | 280 | 175 | 291 | 173 | |
| 86 | | | | | | | | | 256 | 200 | 269 | 191 | 282 | 184 | 295 | 178 | |
| 88 | | | | | | | | | | | 285 | 194 | 285 | 194 | 298 | 187 | |
| 90 | | | | | | | | | | | | | 287 | 203 | 300 | 196 | |
| 92 | | | | | | | | | | | | | | | 303 | 205 | |

* Note: All pressures are listed in psig, and all temperatures in deg. F.



— Shaded Boxes indicate flooded conditions

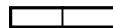

— Rated Design Values. Suction Pressure will be lower than design value if indoor air flow, entering dry bulb, or entering wet bulb temperatures are lower than design.

— Discharge temperatures greater than charted values indicates a refrigerant undercharge.

Table 4. 10 SEER Cooling Charging Charts

Heat Pump in Cooling

3.5 TON

| Suct. Press. | | OUTDOOR TEMPERATURE (°F) | | | | | | | | | | | | | | | |
|--------------|-----|--------------------------|---------------|--------------|---------------|--------------|---------------|--------------|---------------|--------------|---------------|--------------|---------------|--------------|---------------|--------------|---------------|
| | | 70 | | 75 | | 80 | | 85 | | 90 | | 95 | | 100 | | 105 | |
| | | Disch. Temp. | Disch. Press. | Disch. Temp. | Disch. Press. | Disch. Temp. | Disch. Press. | Disch. Temp. | Disch. Press. | Disch. Temp. | Disch. Press. | Disch. Temp. | Disch. Press. | Disch. Temp. | Disch. Press. | Disch. Temp. | Disch. Press. |
| 67 | 184 | 141 | | | | | | | | | | | | | | | |
| 69 | 186 | 146 | 201 | 147 | | | | | | | | | | | | | |
| 71 | 188 | 152 | 203 | 152 | 218 | 154 | | | | | | | | | | | |
| 73 | 189 | 160 | 205 | 158 | 220 | 158 | 235 | 160 | | | | | | | | | |
| 75 | 192 | 163 | 206 | 164 | 223 | 163 | 238 | 164 | 253 | 165 | | | | | | | |
| 77 | | | 210 | 167 | 224 | 169 | 240 | 169 | 255 | 170 | 270 | 171 | | | | | |
| 79 | | | | | 228 | 172 | 242 | 173 | 257 | 174 | 272 | 175 | 287 | 176 | | | |
| 81 | | | | | | | 245 | 177 | 259 | 178 | 274 | 179 | 289 | 180 | 304 | 181 | |
| 83 | | | | | | | 249 | 181 | 263 | 182 | 277 | 183 | 291 | 184 | 306 | 185 | |
| 85 | | | | | | | | | 266 | 186 | 281 | 187 | 295 | 189 | 308 | 189 | |
| 87 | | | | | | | | | | | 284 | 191 | 298 | 193 | 312 | 194 | |
| 89 | | | | | | | | | | | | | 302 | 197 | 316 | 198 | |
| 91 | | | | | | | | | | | | | | | 319 | 203 | |
| 93 | | | | | | | | | | | | | | | | | |

4TON

| Suct. Press. | | OUTDOOR TEMPERATURE (°F) | | | | | | | | | | | | | | | |
|--------------|-----|--------------------------|---------------|--------------|---------------|--------------|---------------|--------------|---------------|--------------|---------------|--------------|---------------|--------------|---------------|--------------|---------------|
| | | 70 | | 75 | | 80 | | 85 | | 90 | | 95 | | 100 | | 105 | |
| | | Disch. Temp. | Disch. Press. | Disch. Temp. | Disch. Press. | Disch. Temp. | Disch. Press. | Disch. Temp. | Disch. Press. | Disch. Temp. | Disch. Press. | Disch. Temp. | Disch. Press. | Disch. Temp. | Disch. Press. | Disch. Temp. | Disch. Press. |
| 68 | 188 | 122 | | | | | | | | | | | | | | | |
| 70 | 191 | 123 | 204 | 135 | | | | | | | | | | | | | |
| 72 | 192 | 140 | 207 | 139 | 222 | 137 | 234 | 146 | 248 | 152 | | | | | | | |
| 74 | 192 | 157 | 208 | 154 | 224 | 151 | 239 | 147 | 252 | 160 | 266 | 160 | | | | | |
| 76 | 193 | 174 | 210 | 168 | 226 | 164 | 241 | 160 | 257 | 164 | 270 | 166 | 284 | 167 | | | |
| 78 | | | 211 | 182 | 227 | 177 | 243 | 174 | 259 | 172 | 274 | 171 | 288 | 173 | 302 | 174 | |
| 80 | | | | | 229 | 190 | 245 | 185 | 261 | 183 | 276 | 181 | 292 | 180 | 307 | 180 | |
| 82 | | | | | | | | | 263 | 193 | 279 | 191 | 294 | 189 | 310 | 188 | |
| 84 | | | | | | | | | | | | | 297 | 199 | 312 | 197 | |
| 86 | | | | | | | | | | | | | 299 | 208 | 315 | 206 | |
| 88 | | | | | | | | | | | | | | 208 | 317 | 215 | |

Table 4a. 10 SEER Cooling Charging Charts

Heat Pump in Cooling

5 TON

| | | OUTDOOR TEMPERATURE (°F) | | | | | | | | | | | | | | | |
|-------------|--------------|----------------------------|--------------|--------------|--------------|--------------|--------------|--------------|--------------|--------------|--------------|--------------|--------------|--------------|--------------|--------------|--------------|
| | | 70 | | 75 | | 80 | | 85 | | 90 | | 95 | | 100 | | 105 | |
| Suct. Pres. | Disch. Temp. | Disch. Pres. | Disch. Temp. | Disch. Pres. | Disch. Temp. | Disch. Pres. | Disch. Temp. | Disch. Pres. | Disch. Temp. | Disch. Pres. | Disch. Temp. | Disch. Pres. | Disch. Temp. | Disch. Pres. | Disch. Temp. | Disch. Pres. | Disch. Temp. |
| 68 | 192 | 157 | | | | | | | | | | | | | | | |
| 70 | 193 | 165 | 208 | 164 | | | | | | | | | | | | | |
| 72 | 194 | 182 | 210 | 172 | 226 | 164 | 239 | 165 | 252 | 167 | | | | | | | |
| 74 | 195 | 199 | 211 | 187 | 227 | 178 | 243 | 168 | 256 | 175 | 269 | 171 | | | | | |
| 76 | 195 | 216 | 213 | 201 | 229 | 191 | 245 | 181 | 260 | 180 | 273 | 178 | 287 | 175 | | | |
| 78 | | | 214 | 215 | 231 | 204 | 247 | 195 | 262 | 188 | 278 | 183 | 291 | 181 | 304 | 179 | |
| 80 | | | | | 232 | 216 | 249 | 207 | 265 | 199 | 280 | 193 | 295 | 188 | 309 | 185 | |
| 82 | | | | | | | | | 267 | 210 | 282 | 203 | 298 | 197 | 313 | 192 | |
| 84 | | | | | | | | | | | | | 300 | 206 | 315 | 201 | |
| 86 | | | | | | | | | | | | | 303 | 216 | 318 | 210 | |
| 88 | | | | | | | | | | | | | | 320 | 219 | | |

* Note: All pressures are listed in psig. and all temperatures in deg. F.



— Shaded Boxes indicate flooded conditions



— Rated Design Values. Suction Pressure will be lower than design value if indoor air flow, entering dry bulb, or entering wet bulb temperatures are lower than design.

— Discharge temperatures greater than charted values indicates a refrigerant undercharge.

Table 4b. 10 SEER Cooling Charging Charts

Heat Pump in Cooling

3TON

| Suct. Pres. | | OUTDOOR TEMPERATURE (°F) | | | | | | | | | | | | | | | |
|-------------|-----|----------------------------|--------------|--------------|--------------|--------------|--------------|--------------|--------------|--------------|--------------|--------------|--------------|--------------|--------------|--------------|--------------|
| | | 70 | | 75 | | 80 | | 85 | | 90 | | 95 | | 100 | | 105 | |
| | | Disch. Temp. | Disch. Pres. | Disch. Temp. | Disch. Pres. | Disch. Temp. | Disch. Pres. | Disch. Temp. | Disch. Pres. | Disch. Temp. | Disch. Pres. | Disch. Temp. | Disch. Pres. | Disch. Temp. | Disch. Pres. | Disch. Temp. | Disch. Pres. |
| 76 | 170 | 138 | | | | | | | | | | | | | | | |
| 78 | 171 | 149 | 185 | 146 | | | | | | | | | | | | | |
| 80 | 172 | 165 | 188 | 156 | 202 | 148 | 215 | 149 | 228 | 152 | | | | | | | |
| 82 | 173 | 182 | 189 | 171 | 204 | 162 | 219 | 154 | 231 | 160 | 244 | 157 | | | | | |
| 84 | 173 | 199 | 190 | 185 | 206 | 176 | 221 | 166 | 235 | 166 | 248 | 163 | 261 | 161 | | | |
| 86 | | | 191 | 199 | 207 | 188 | 222 | 181 | 237 | 175 | 252 | 170 | 265 | 168 | 278 | 167 | |
| 88 | | | | | 209 | 201 | 224 | 192 | 239 | 185 | 254 | 180 | 268 | 176 | 282 | 173 | |
| 90 | | | | | | | | | 241 | 196 | 256 | 190 | 271 | 185 | 285 | 181 | |
| 92 | | | | | | | | | | | | | 273 | 195 | 287 | 190 | |
| 94 | | | | | | | | | | | | | 275 | 204 | 290 | 199 | |
| 96 | | | | | | | | | | | | | | | 292 | 208 | |

4 TON

| Suct. Pres. | | OUTDOOR TEMPERATURE (°F) | | | | | | | | | | | | | | | |
|-------------|-----|----------------------------|--------------|--------------|--------------|--------------|--------------|--------------|--------------|--------------|--------------|--------------|--------------|--------------|--------------|--------------|--------------|
| | | 70 | | 75 | | 80 | | 85 | | 90 | | 95 | | 100 | | 105 | |
| | | Disch. Temp. | Disch. Pres. | Disch. Temp. | Disch. Pres. | Disch. Temp. | Disch. Pres. | Disch. Temp. | Disch. Pres. | Disch. Temp. | Disch. Pres. | Disch. Temp. | Disch. Pres. | Disch. Temp. | Disch. Pres. | Disch. Temp. | Disch. Pres. |
| 74 | 176 | 143 | | | | | | | | | | | | | | | |
| 76 | 178 | 149 | 191 | 150 | | | | | | | | | | | | | |
| 78 | 179 | 166 | 194 | 157 | 209 | 148 | 221 | 150 | 233 | 151 | | | | | | | |
| 80 | 180 | 183 | 195 | 171 | 211 | 162 | 225 | 153 | 237 | 159 | 250 | 154 | | | | | |
| 82 | 180 | 200 | 197 | 186 | 212 | 176 | 227 | 165 | 242 | 164 | 254 | 161 | 267 | 157 | | | |
| 84 | | | 198 | 200 | 214 | 188 | 229 | 179 | 244 | 172 | 258 | 166 | 271 | 164 | 284 | 161 | |
| 86 | | | | | 215 | 201 | 231 | 191 | 246 | 183 | 261 | 176 | 275 | 170 | 289 | 167 | |
| 88 | | | | | | | | | 248 | 193 | 263 | 186 | 278 | 180 | 292 | 174 | |
| 90 | | | | | | | | | | | | | 280 | 189 | 295 | 183 | |
| 92 | | | | | | | | | | | | | 282 | 198 | 297 | 192 | |
| 94 | | | | | | | | | | | | | | | 300 | 201 | |

Table 5. 12 SEER Cooling Charging Charts

Heat Pump in Cooling

5 TON

| | | OUTDOOR TEMPERATURE (° F) | | | | | | | | | | | | | | | |
|-------------|--------------|-----------------------------|--------------|--------------|--------------|--------------|--------------|--------------|--------------|--------------|--------------|--------------|--------------|--------------|--------------|--------------|--------------|
| | | 70 | | 75 | | 80 | | 85 | | 90 | | 95 | | 100 | | 105 | |
| Suct. Pres. | Disch. Temp. | Disch. Pres. | Disch. Temp. | Disch. Pres. | Disch. Temp. | Disch. Pres. | Disch. Temp. | Disch. Pres. | Disch. Temp. | Disch. Pres. | Disch. Temp. | Disch. Pres. | Disch. Temp. | Disch. Pres. | Disch. Temp. | Disch. Pres. | Disch. Temp. |
| 74 | 189 | 147 | | | | | | | | | | | | | | | |
| 76 | 190 | 155 | 205 | 154 | | | | | | | | | | | | | |
| 78 | 191 | 172 | 208 | 163 | 224 | 155 | 237 | 155 | 252 | 157 | | | | | | | |
| 80 | 192 | 189 | 209 | 177 | 225 | 168 | 241 | 159 | 255 | 165 | 270 | 161 | | | | | |
| 82 | 192 | 206 | 210 | 192 | 227 | 182 | 243 | 172 | 259 | 171 | 274 | 168 | 288 | 165 | | | |
| 84 | | | 211 | 206 | 229 | 195 | 245 | 186 | 261 | 180 | 277 | 174 | 292 | 171 | 306 | 169 | |
| 86 | | | | | 230 | 207 | 247 | 198 | 264 | 190 | 280 | 184 | 295 | 179 | 311 | 175 | |
| 88 | | | | | | | | | 266 | 201 | 282 | 194 | 298 | 188 | 314 | 183 | |
| 90 | | | | | | | | | | | | | 300 | 198 | 316 | 192 | |
| 92 | | | | | | | | | | | | | 303 | 207 | 319 | 201 | |
| 94 | | | | | | | | | | | | | | 321 | 210 | 210 | |

* Note: All pressures are listed in psig. and all temperatures in deg. F.

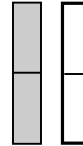

— Shaded Boxes indicate flooded conditions

— Rated Design Values. Suction Pressure will be lower than design value if indoor air flow, entering dry bulb, or entering wet bulb temperatures are lower than design.

— Discharge temperatures greater than charted values indicates a refrigerant undercharge.

Table 5a. 12 SEER Cooling Charging Charts



**INSTALLER: PLEASE LEAVE THESE
INSTALLATION INSTRUCTIONS WITH
THE HOMEOWNER.**



708135A (Replaces 7081350)

Specifications and illustrations subject to change
without notice and without incurring obligations.
Printed in U.S.A. (06/02)